

ARQUITECTURA

ESP. ARQ. PABLO PEIRONE

ESP. ARQ. JULIA CERUTTI

AUDITORIOS

Iglesia y salón de usos múltiples fuego nuevo





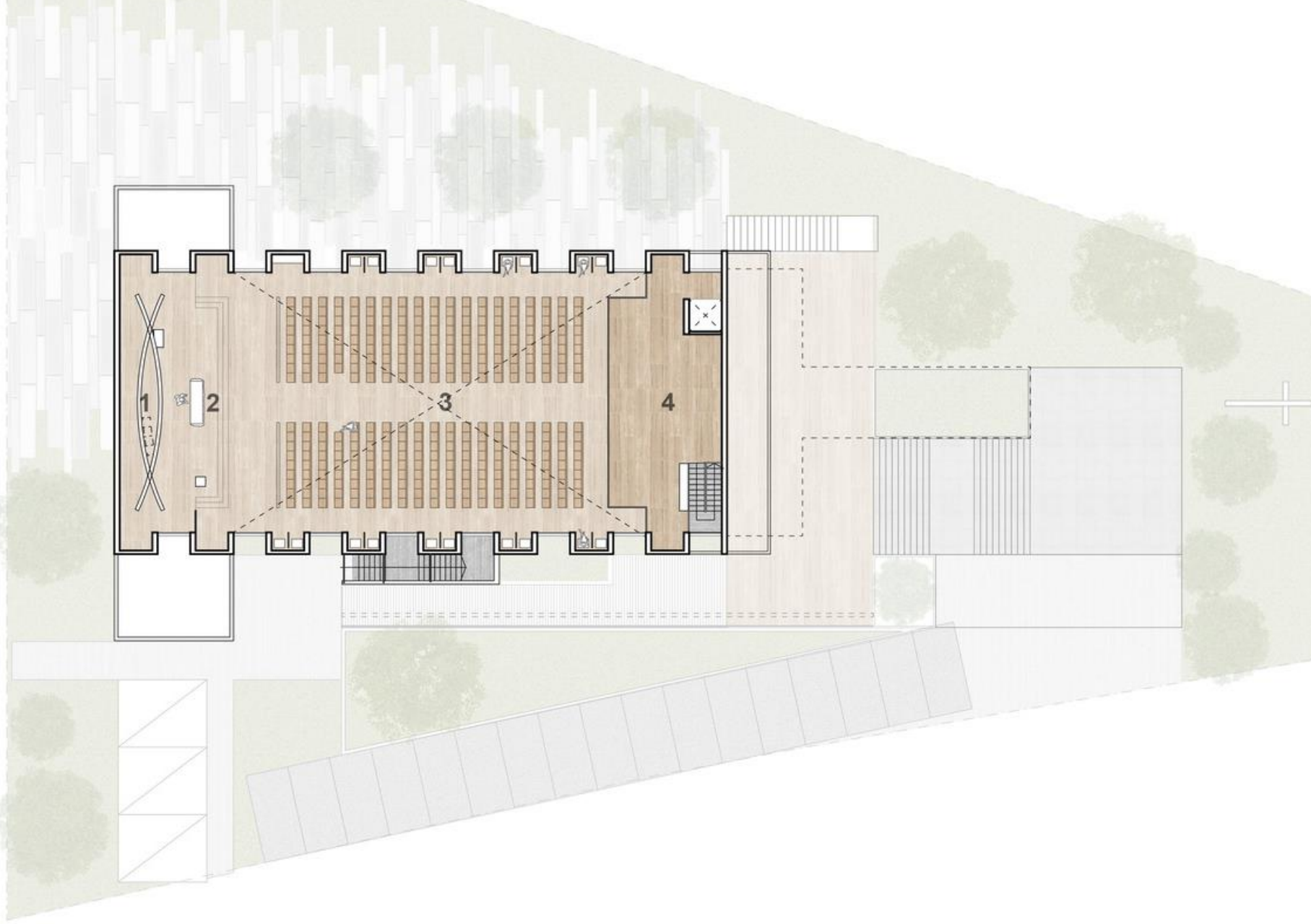

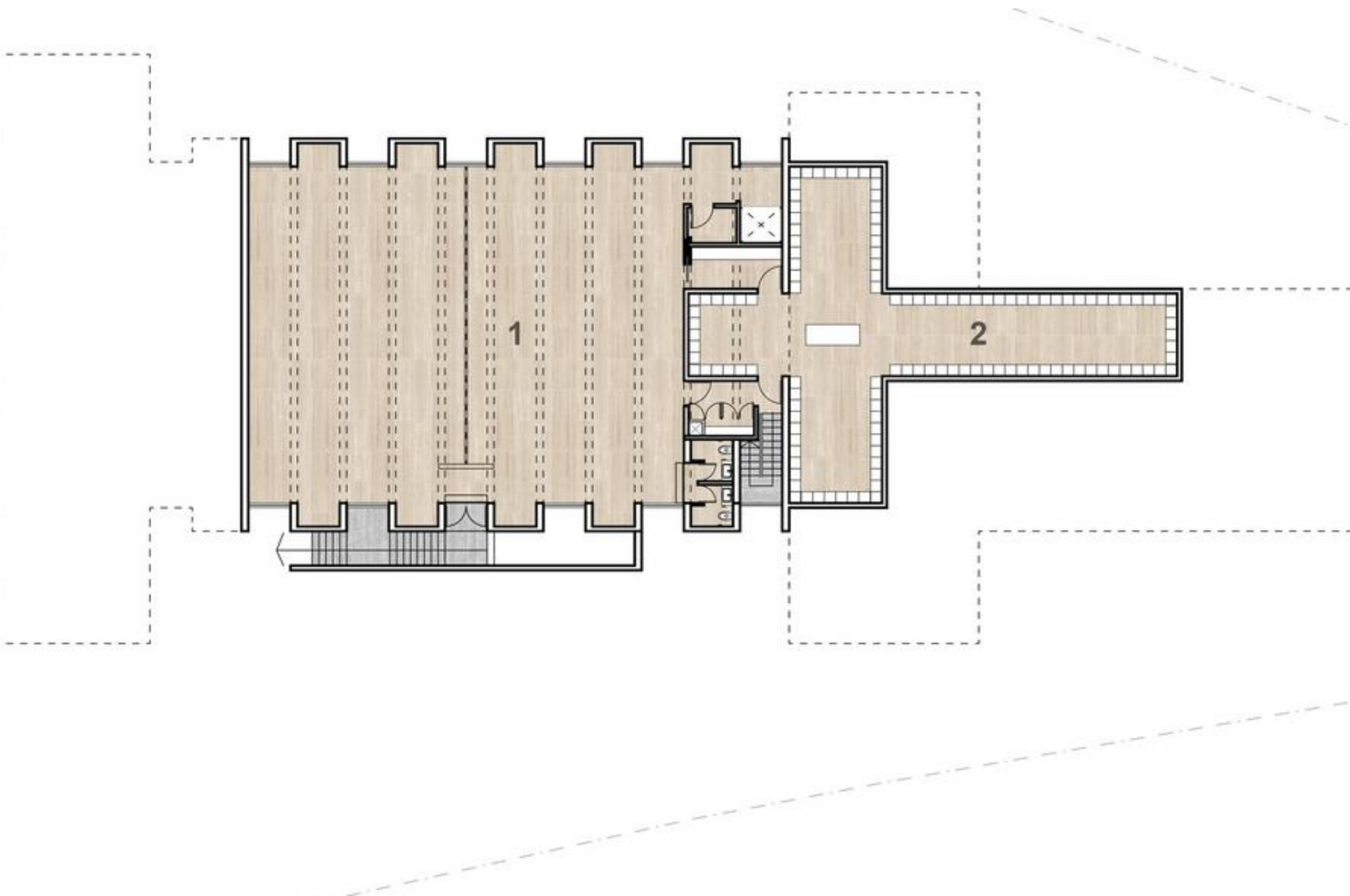

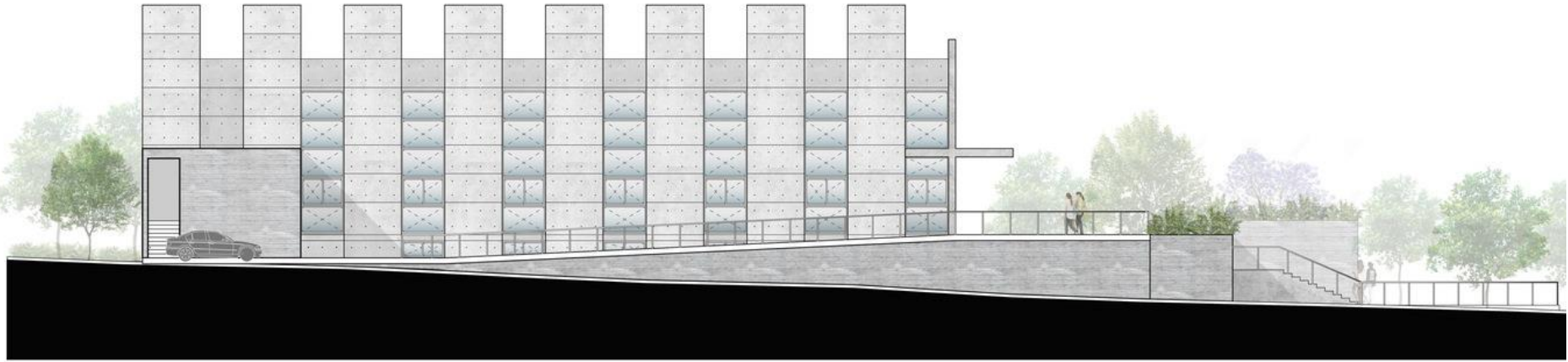

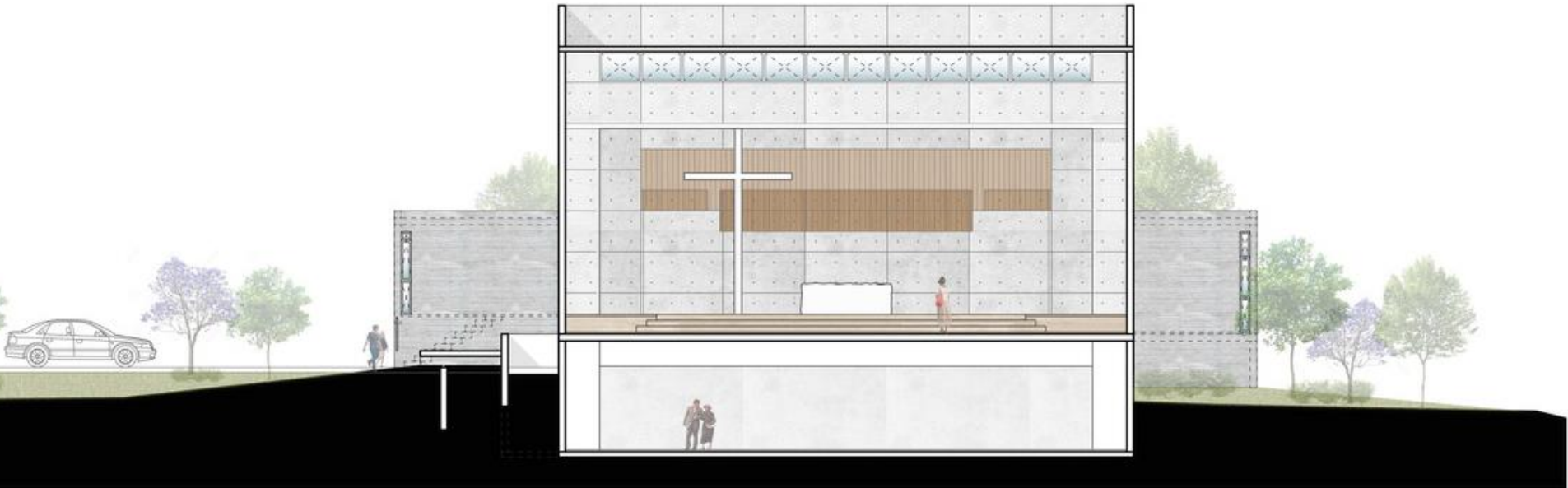

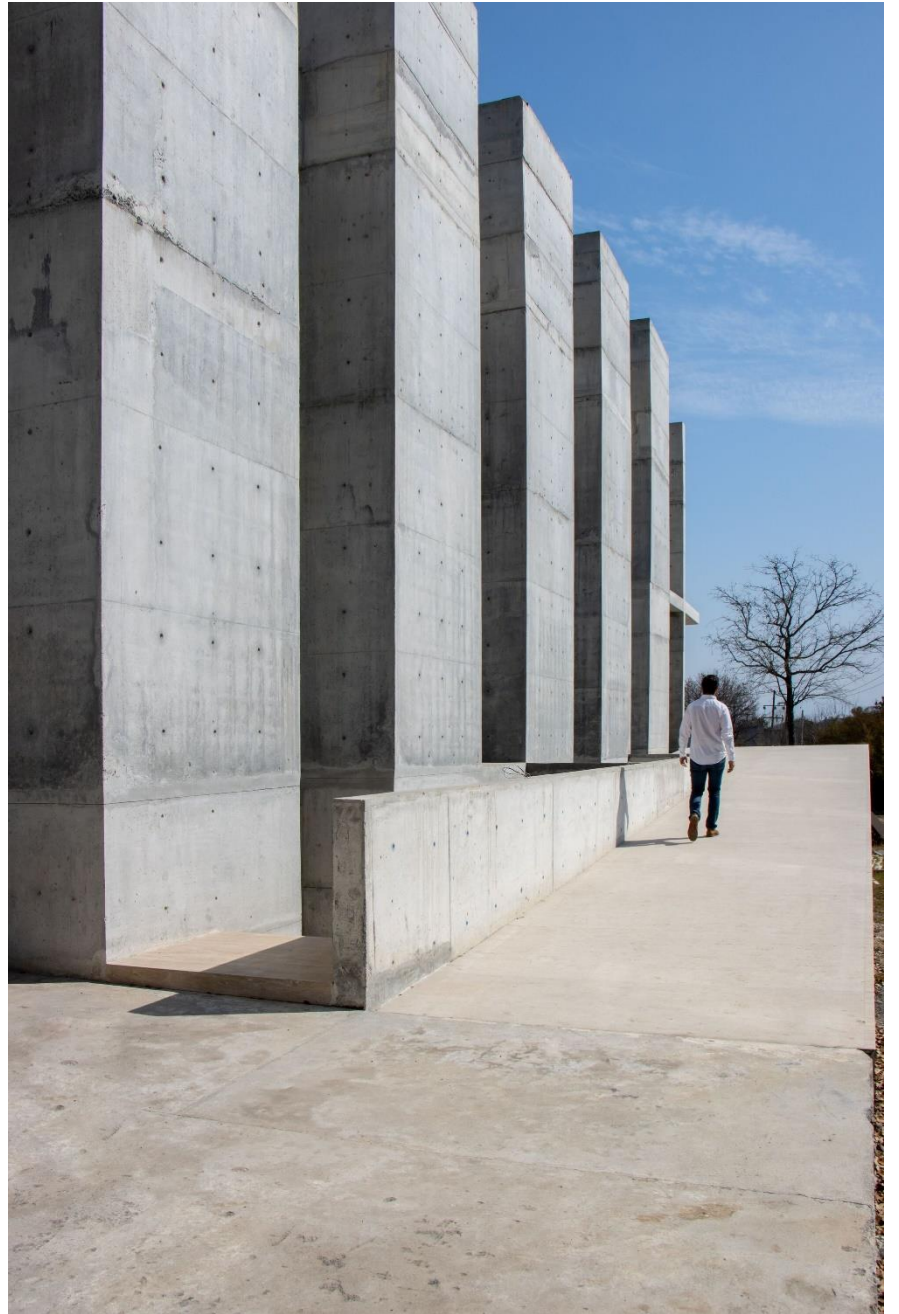







Salon de usos multiples ty roz / tracks



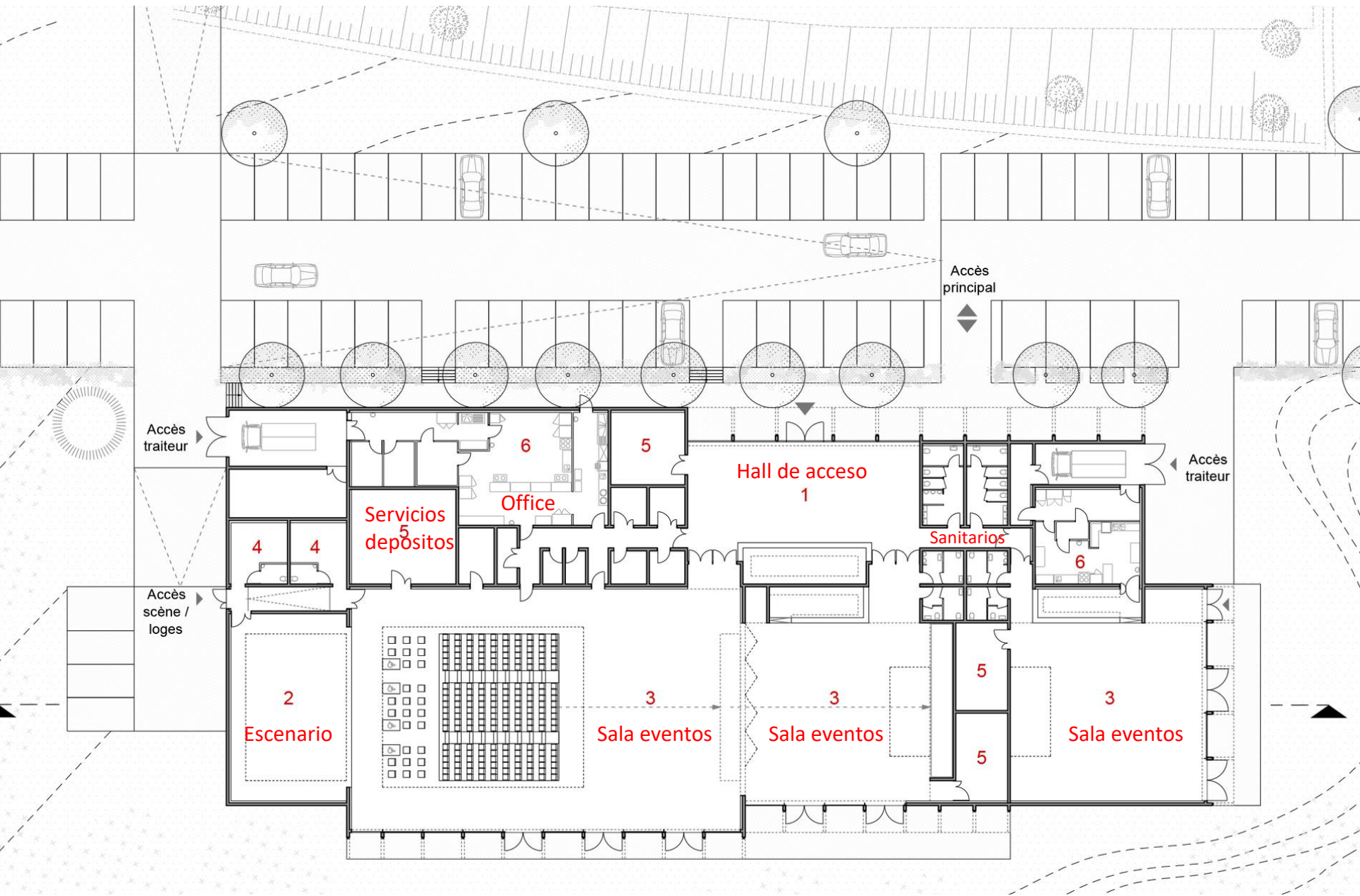

- 1. Hall d'accueil
- 2. Scène
- 3. Salle festive
- 4. Loge
- 5. Local rangement
- 6. Office

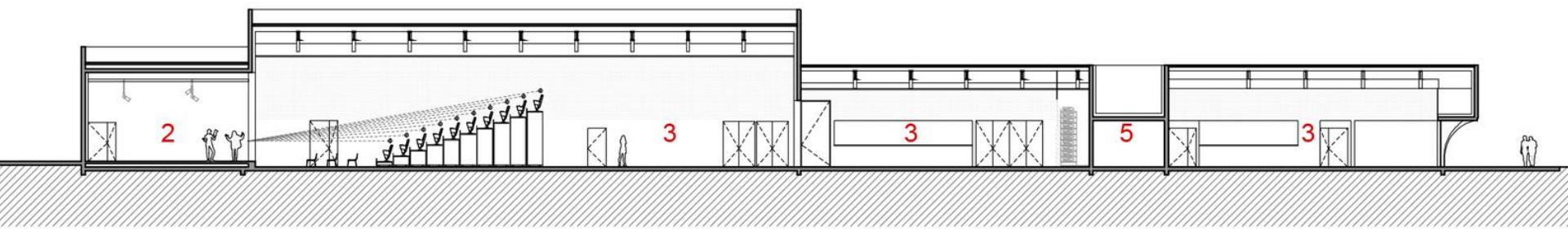
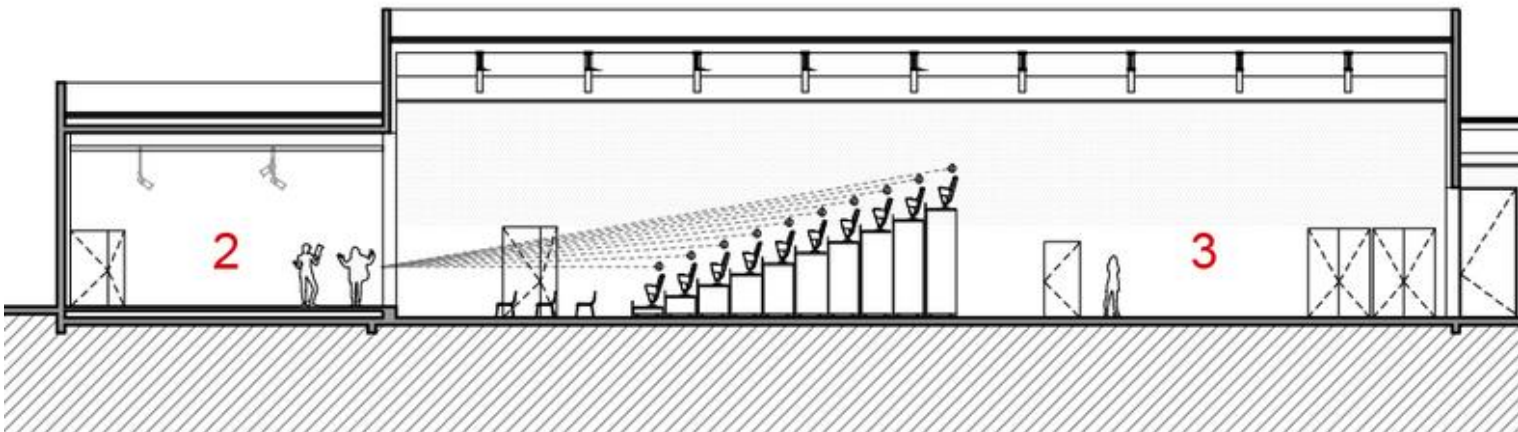



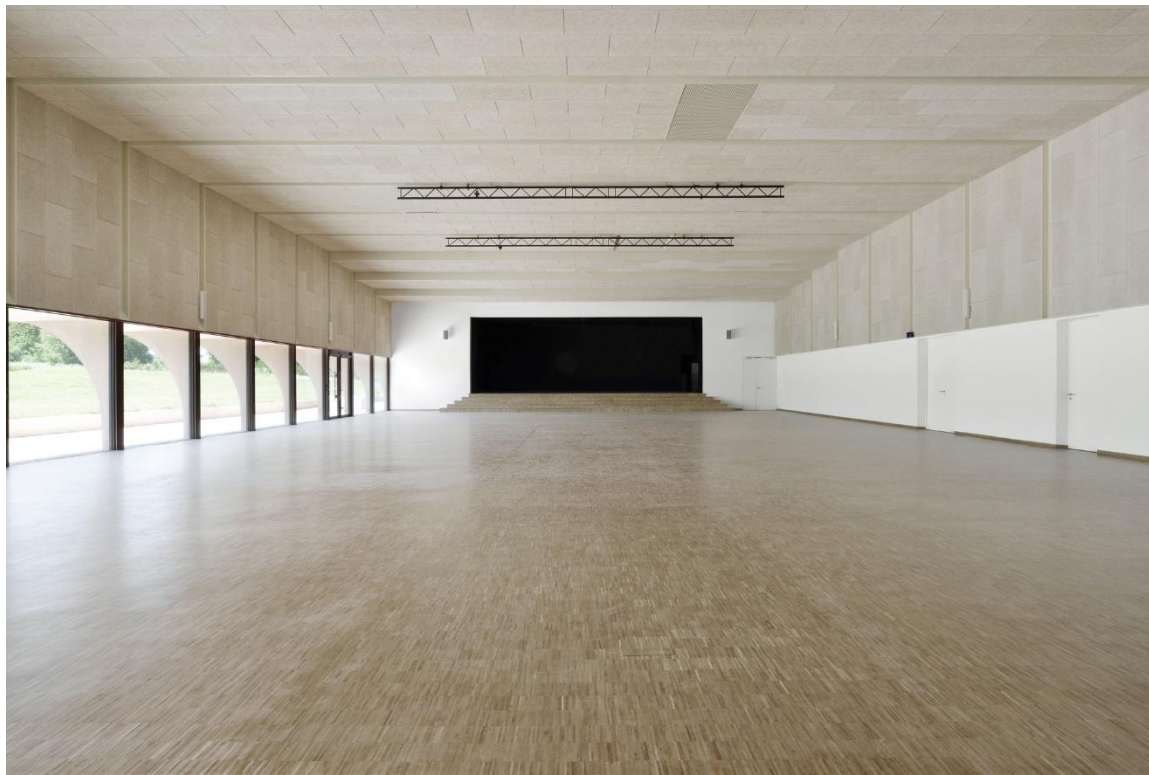

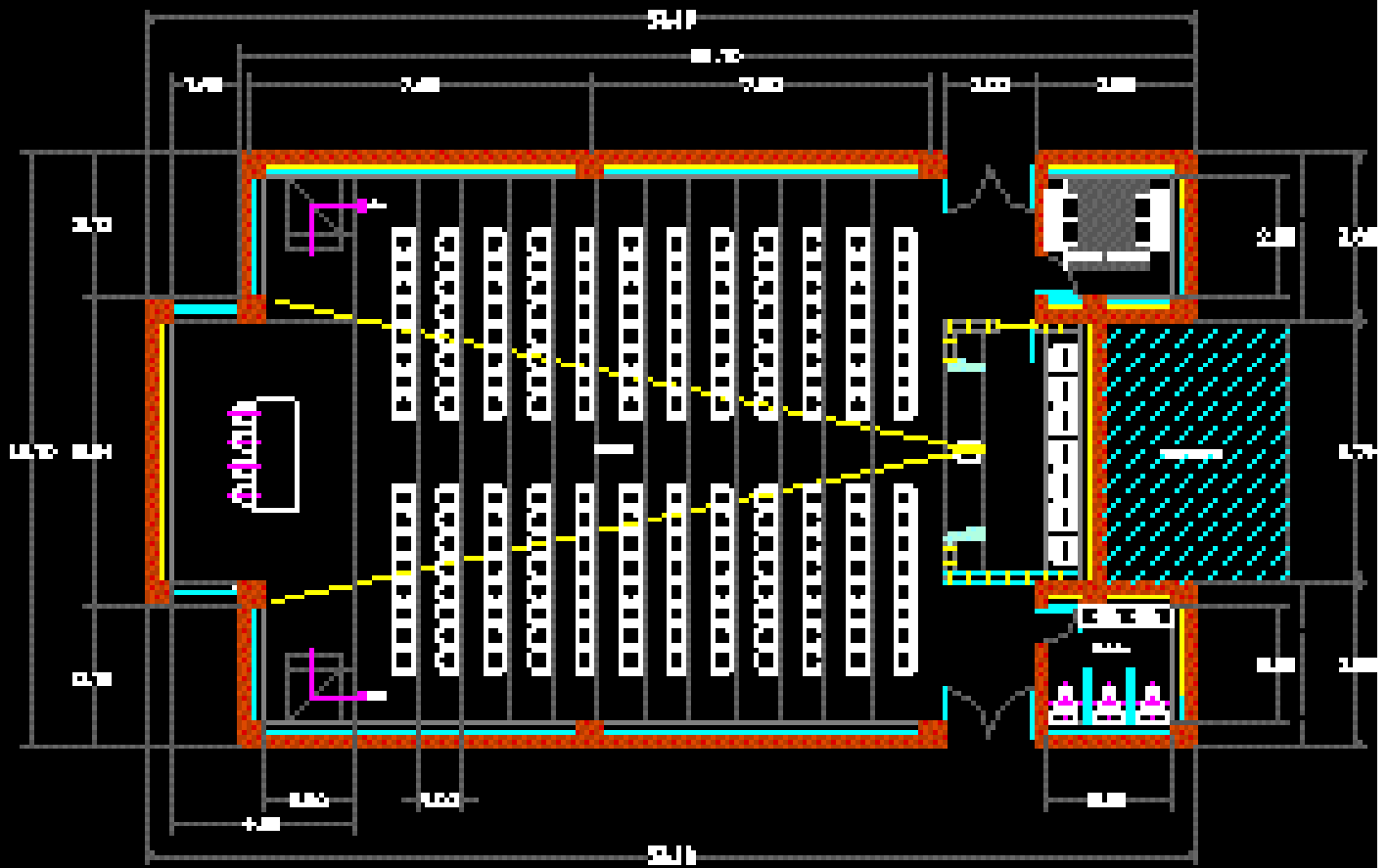

PLANTA

Almoxarifado

Prof. L. L. L.

FOYER: vestíbulo, recibidor, salón de descanso, salón de espera, salón de estar.



Su superficie tiene alrededor de $\frac{1}{3}$ de la sala.

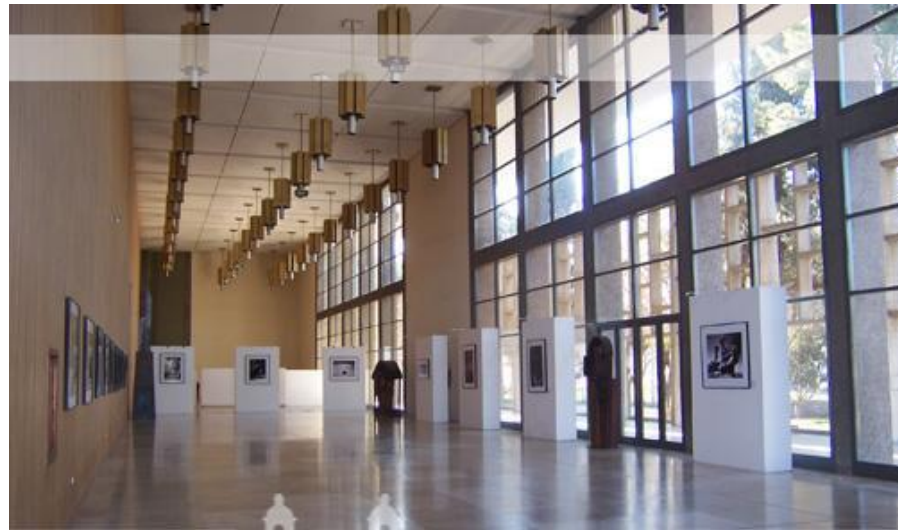

Destinado a equipamiento para estar,
acreditaciones en caso de una conferencia o
congreso.
stand en caso de presentación.



ESCENARIO

Escenario espacio, lugar o cobijo destinado a la representación de obras de teatro, otras artes escénicas o conferencias, congresos, mítines, etc.

- **Espacio escénico** para los actores o intérpretes y el punto focal para el público. El escenario puede consistir en una plataforma (a menudo elevada). En algunos casos, pueden ser temporales o ajustables, pero en los teatros y en otros edificios de este tipo, es un elemento estable y permanente.

PROPORCIONES

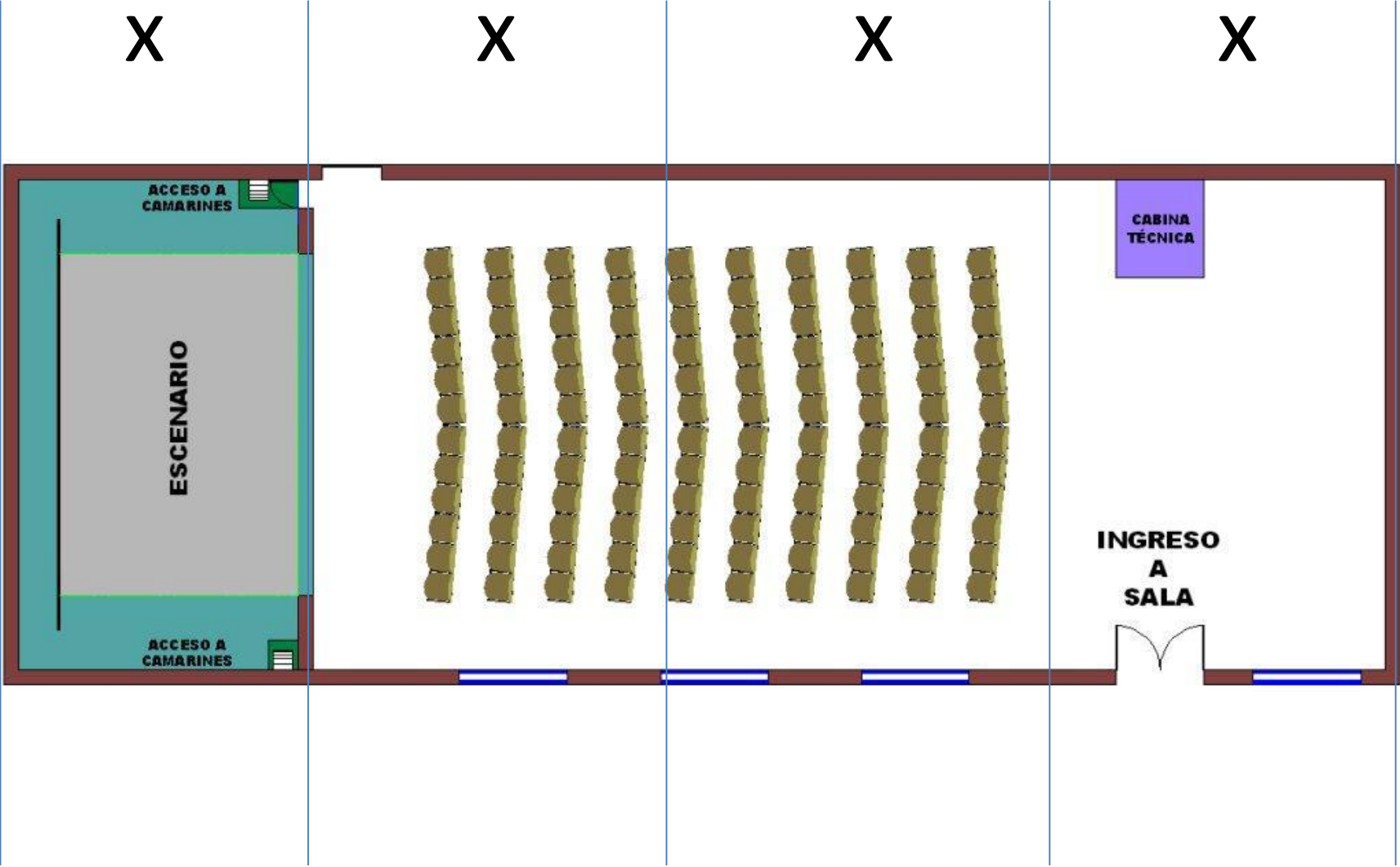

GRADAS- BUTACAS



móviles , fijas, rebatibles



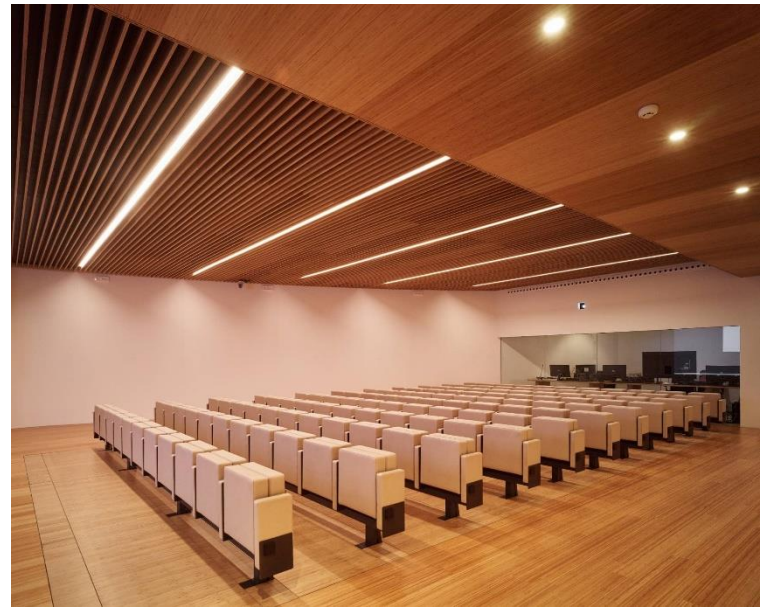
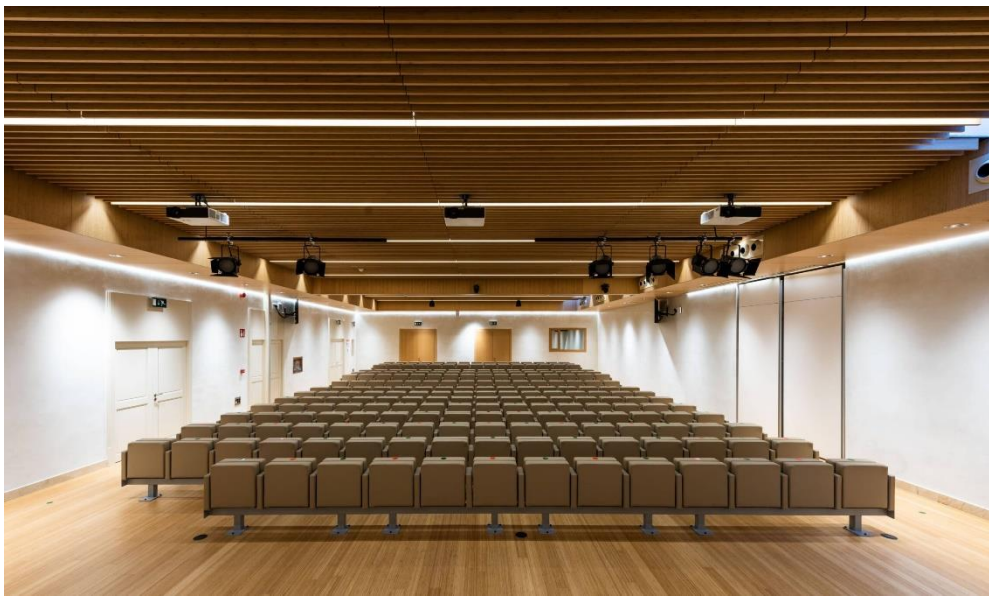

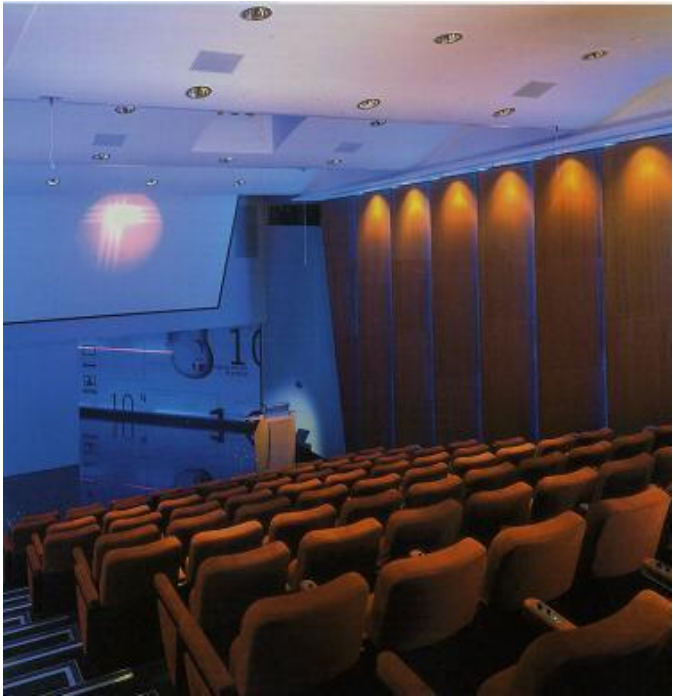

Salón multiuso Cafayate



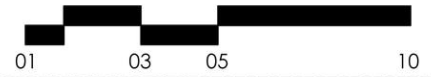

A

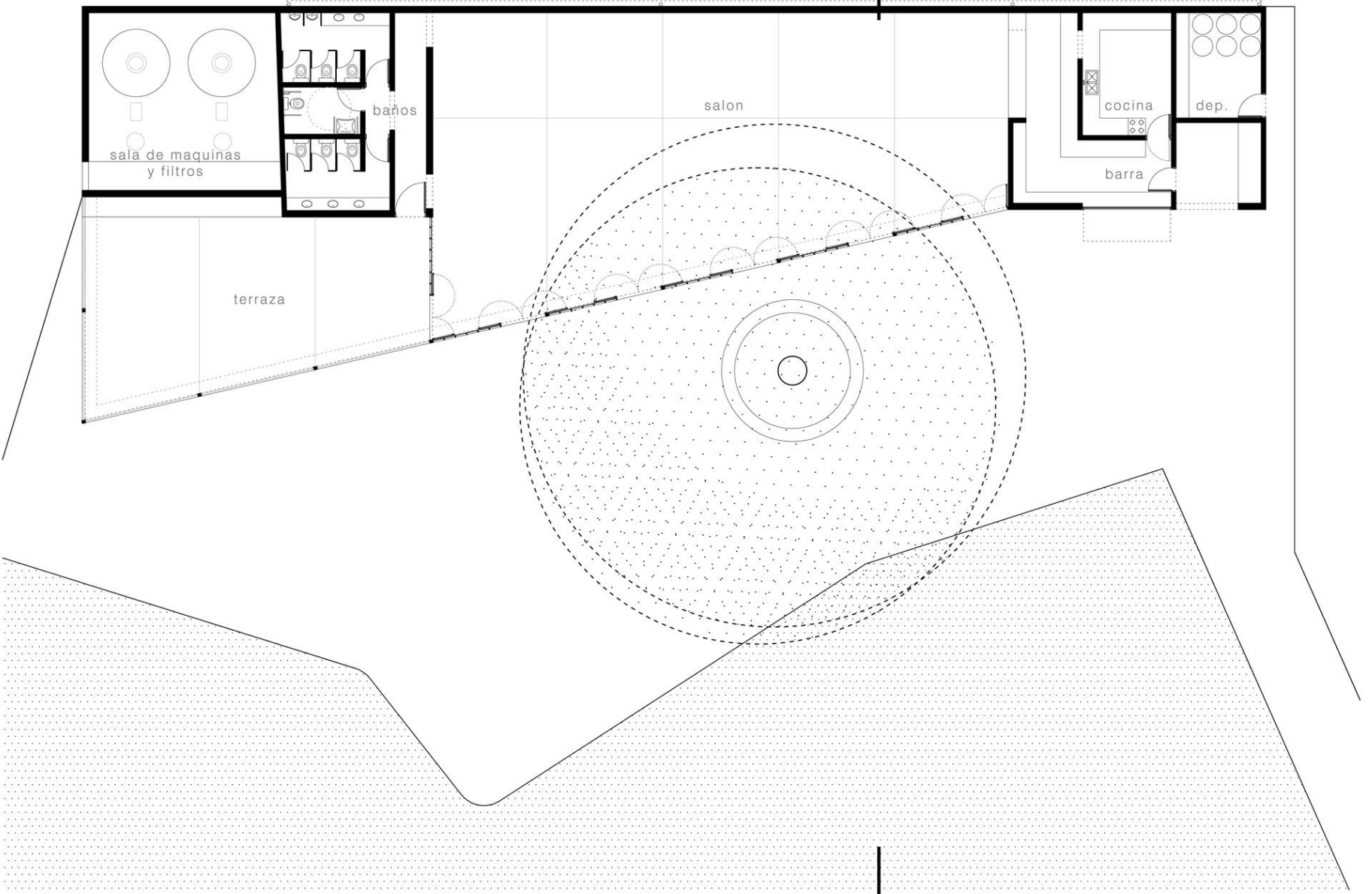

A

PLANTA

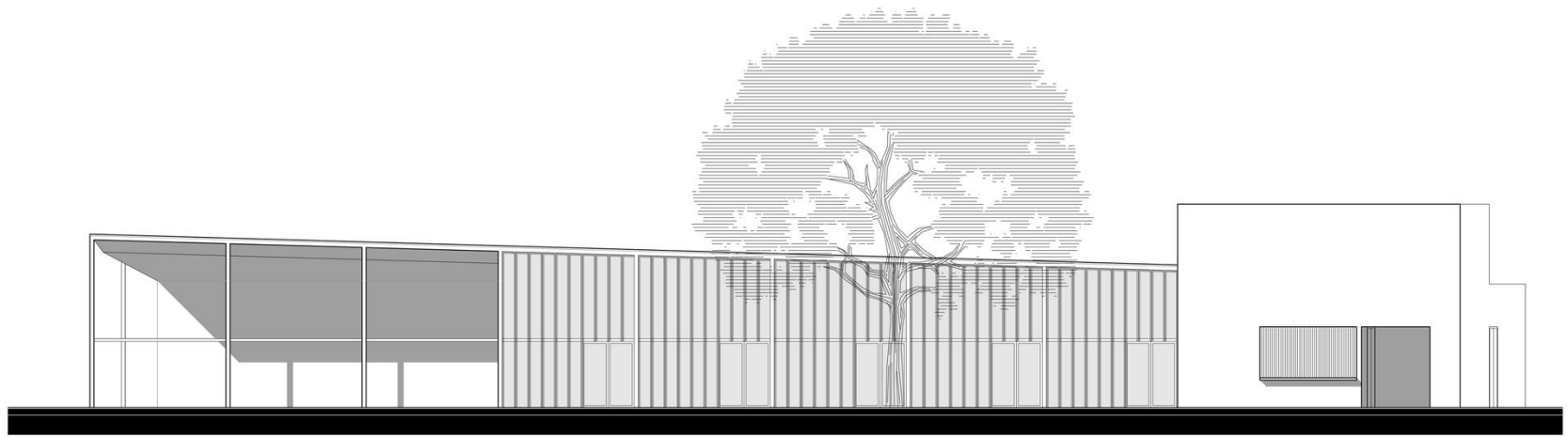

VISTA FRENTE



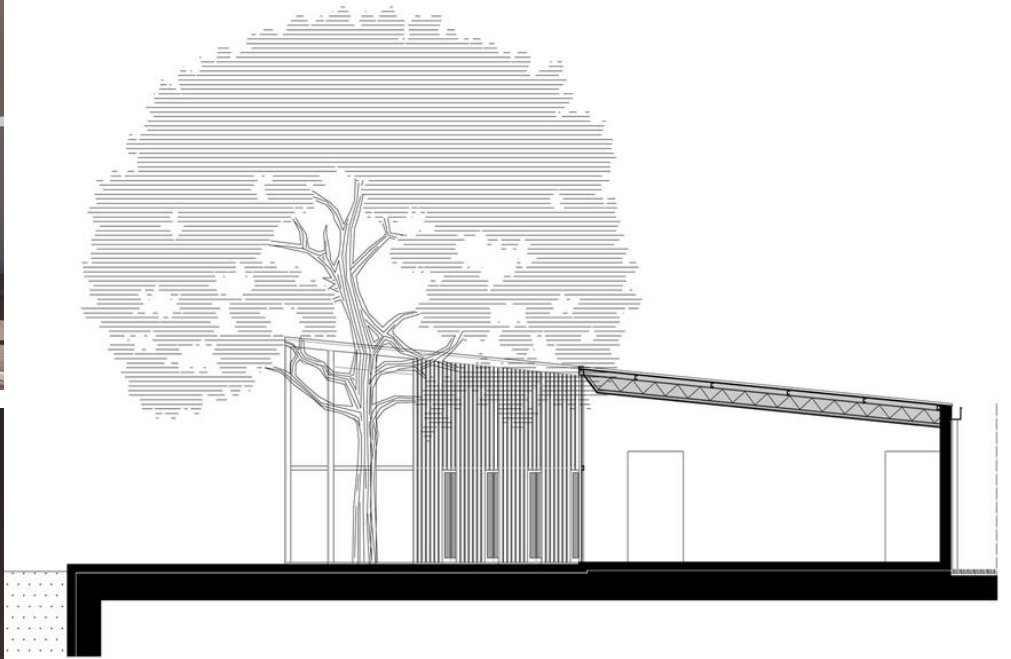

CORTE A-A







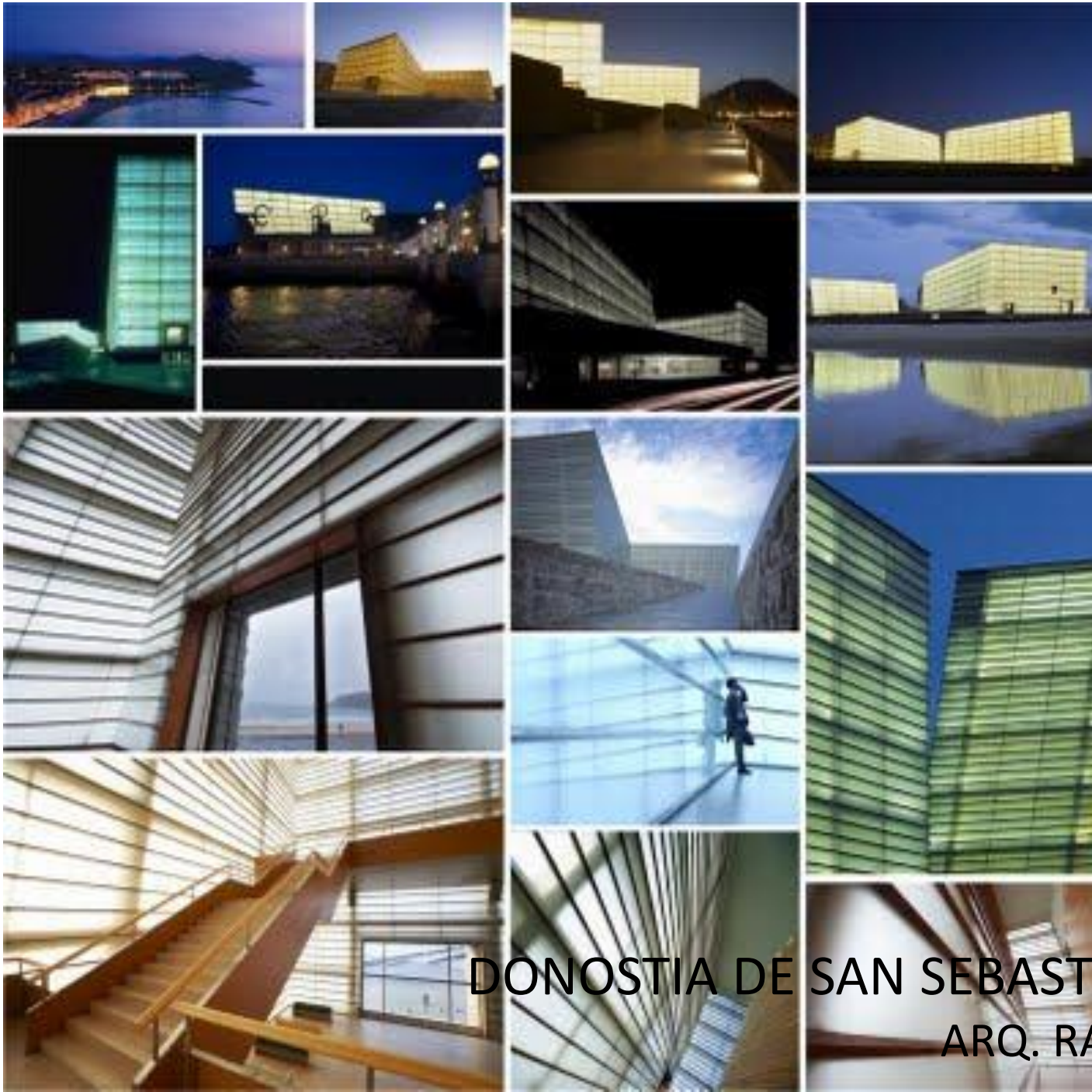

CENTRO
KURSAAL
DONOSTIA DE SAN SEBASTIAN ESPAÑA
ARQ. RAFAEL MONEO





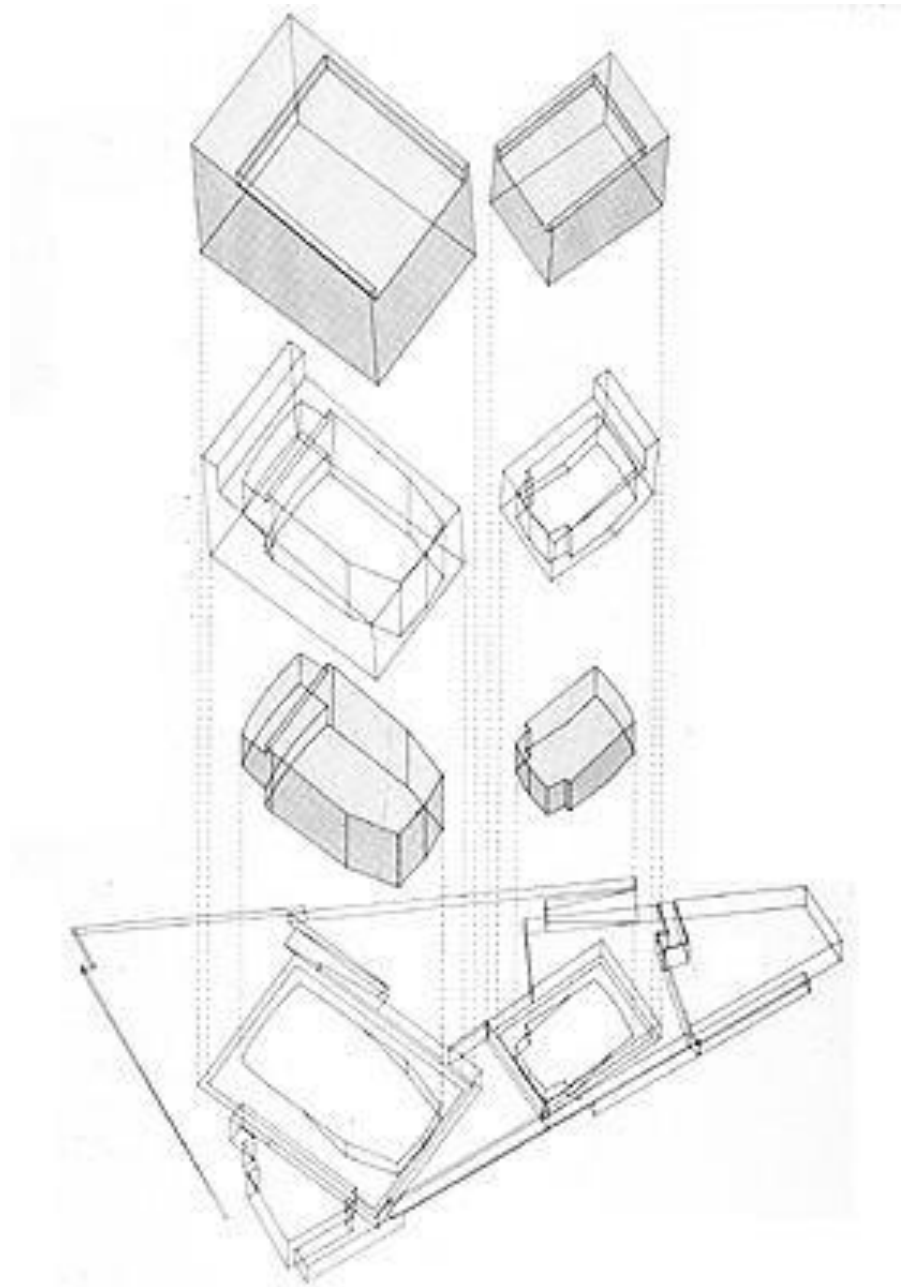
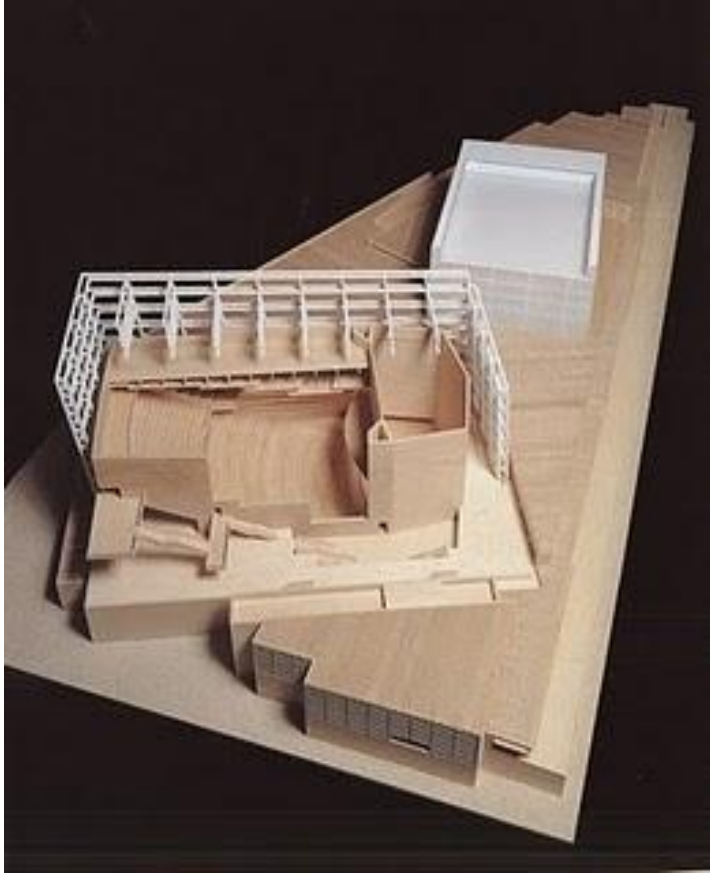

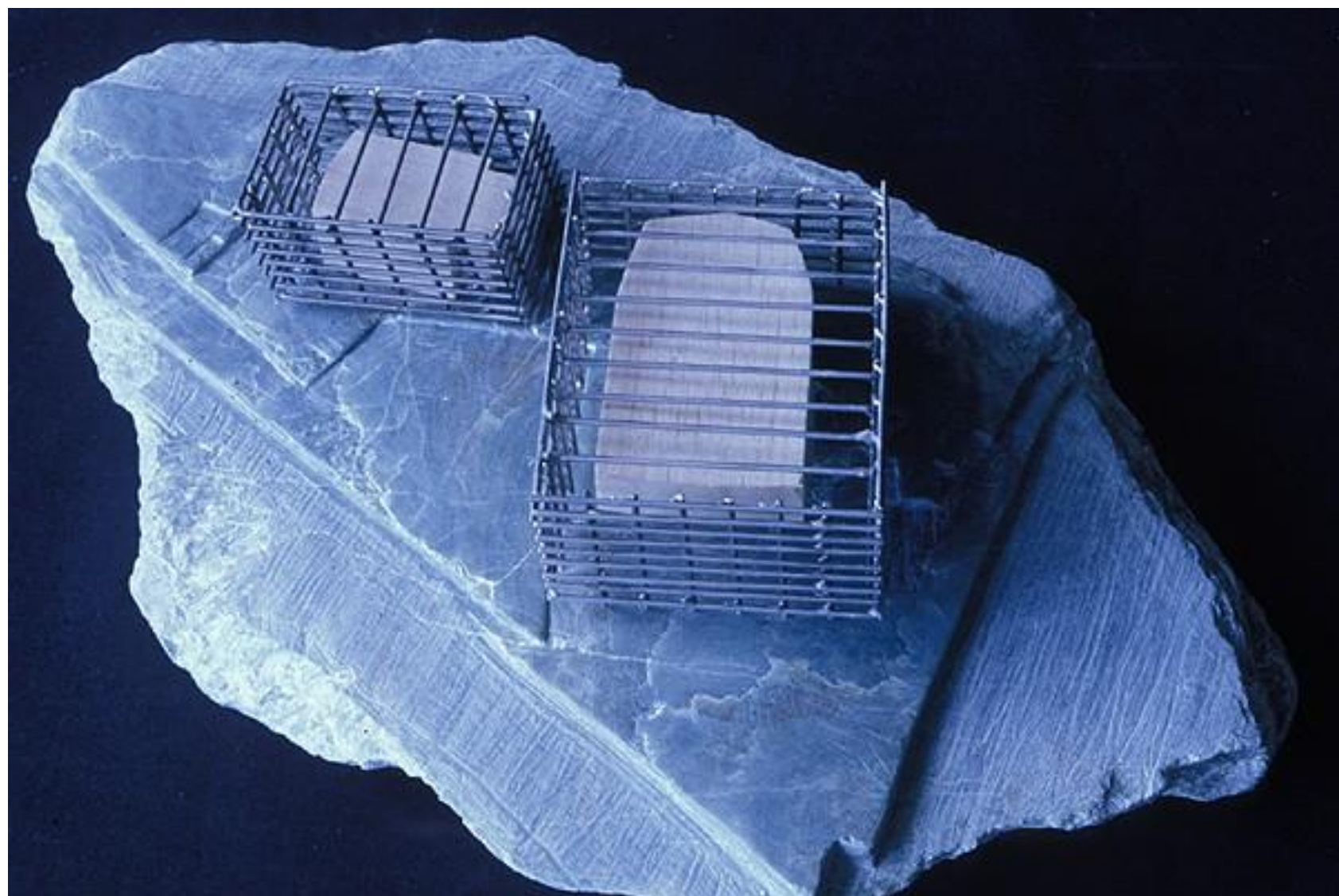

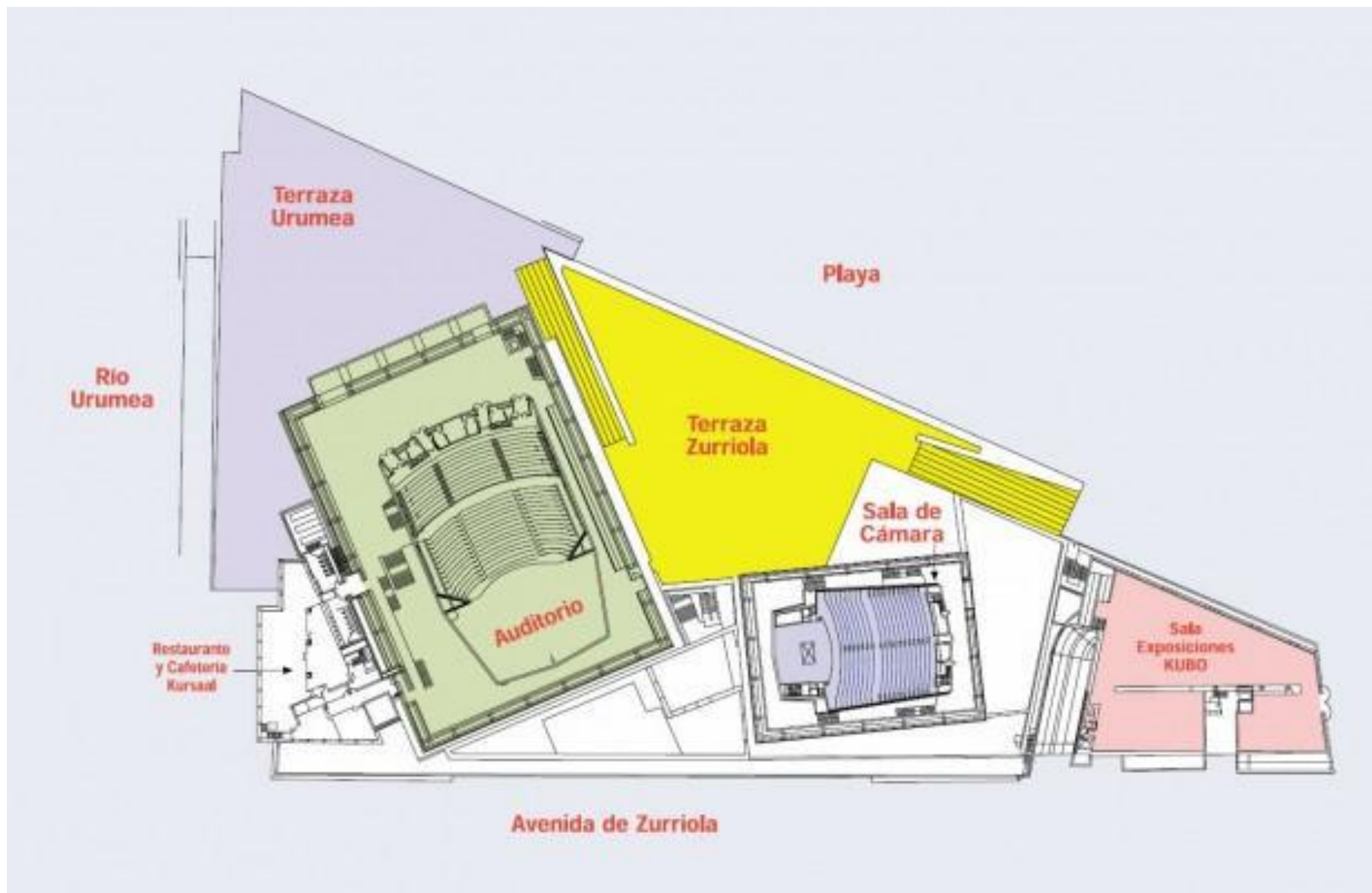

BOCA DE INCENDIOS EQUIPADA
CON DOS EXTINTORES (BE)

FLA. 1 RESERVADA MINUSVALIDOS
ESPACIO CONVERTIBLE PREVIO AVISO

624 BUTACAS

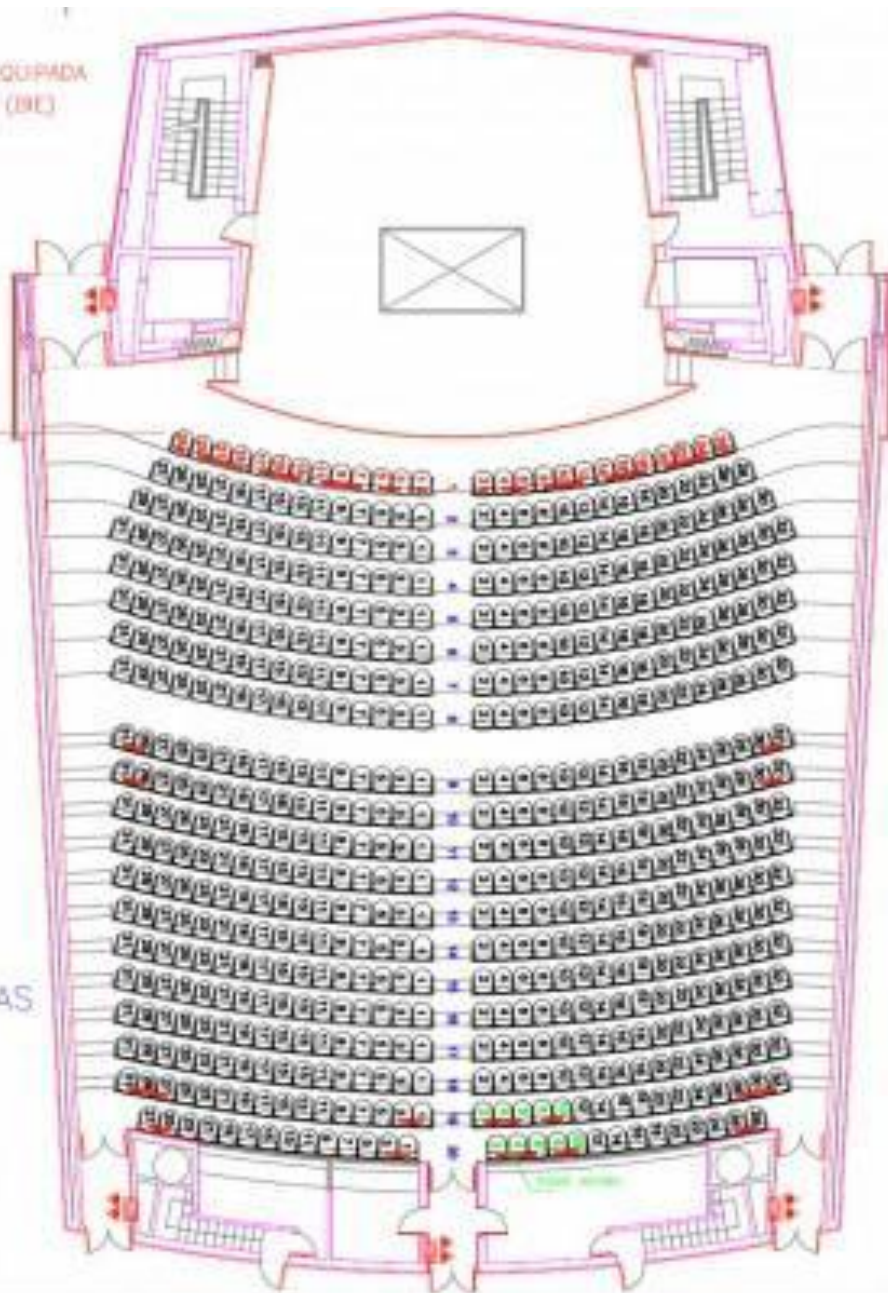



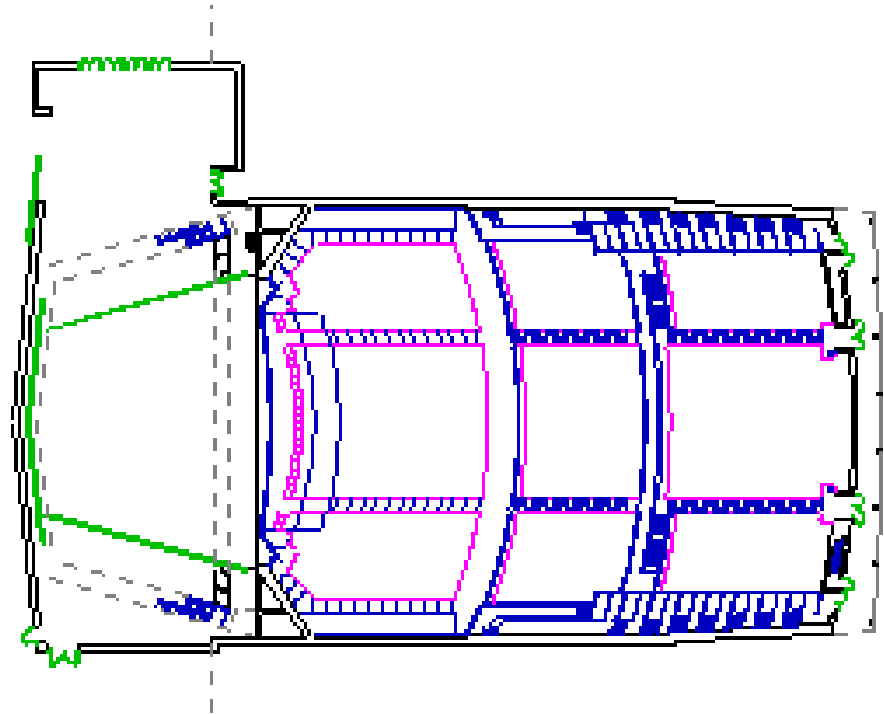
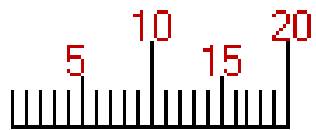
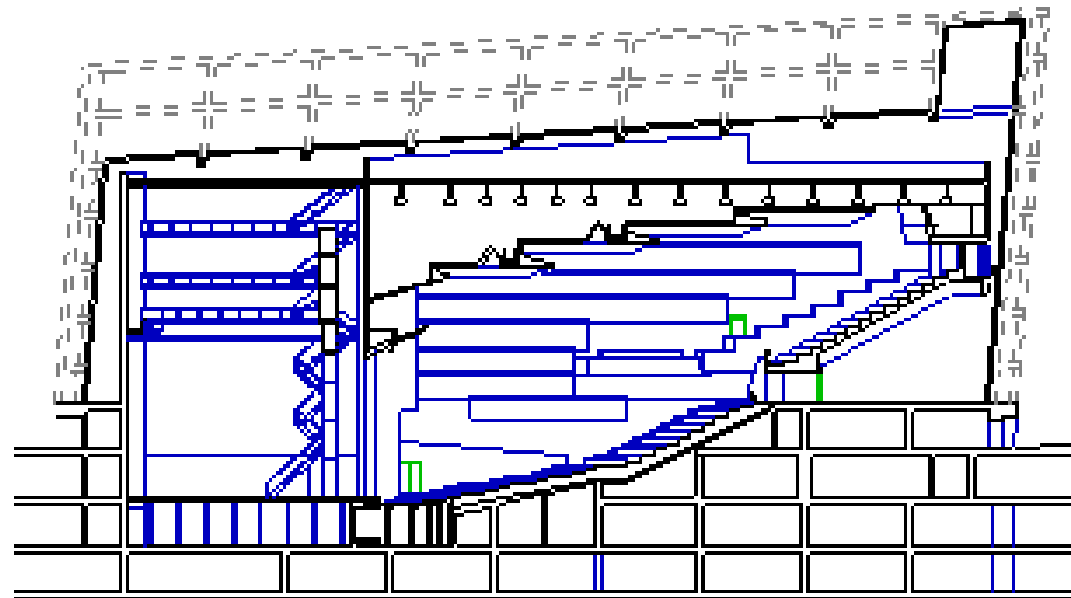
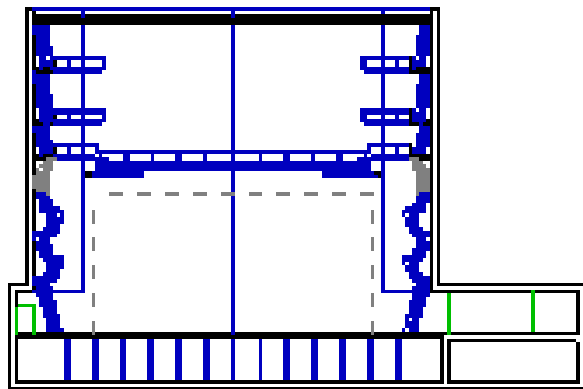

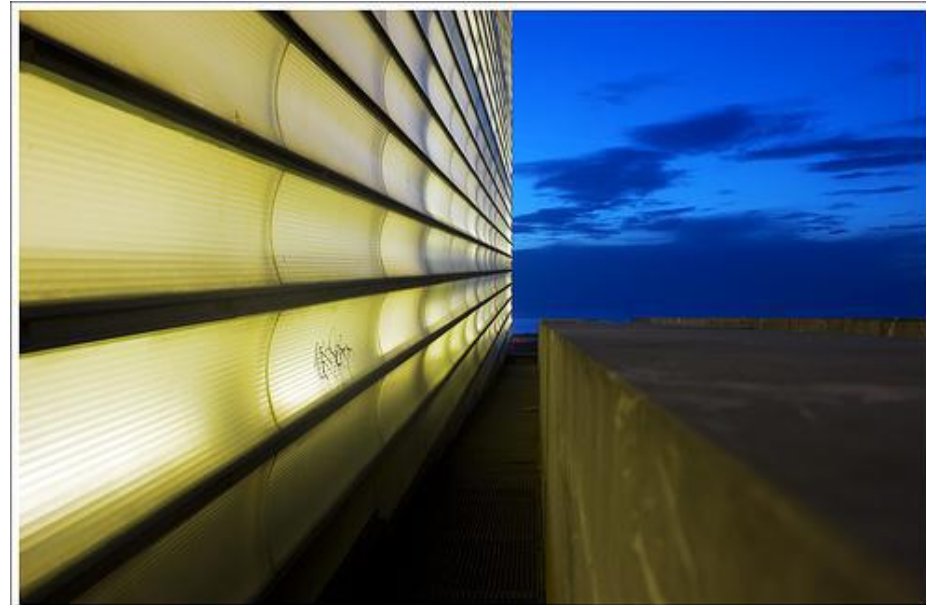













Centro de exposiciones y convenciones Neuquén





PLANTA GENERAL



PLANTA BAJA







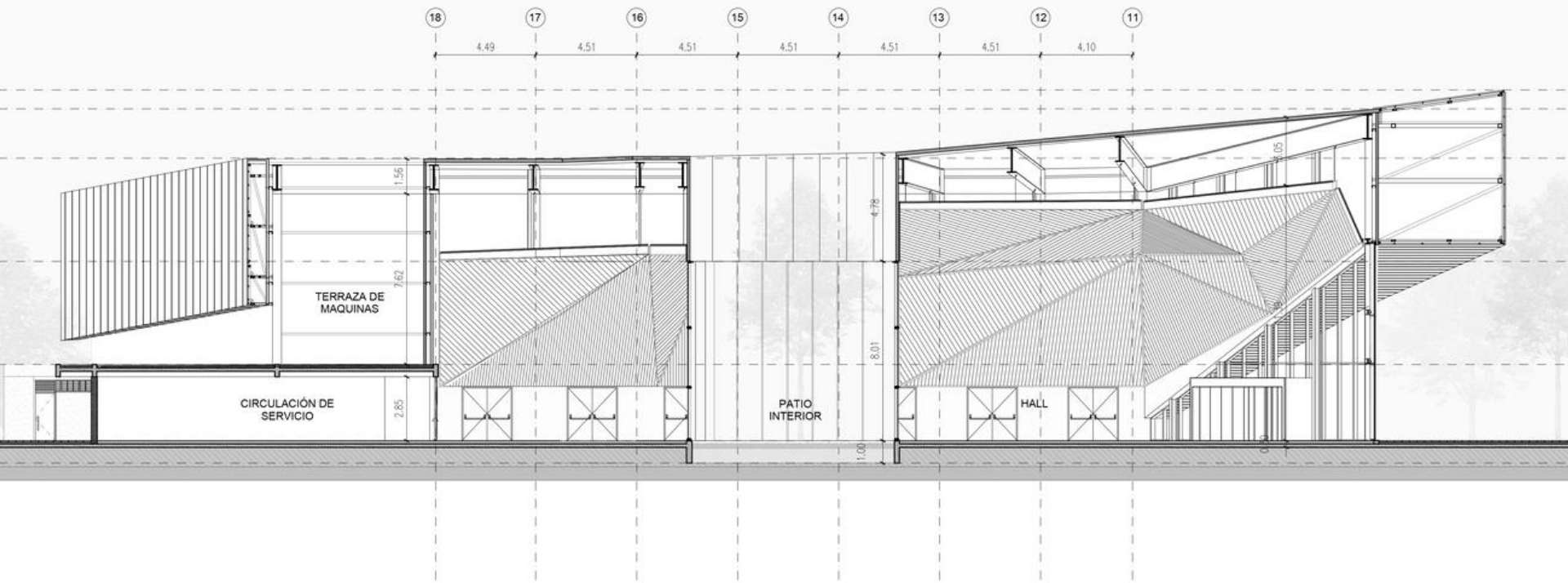

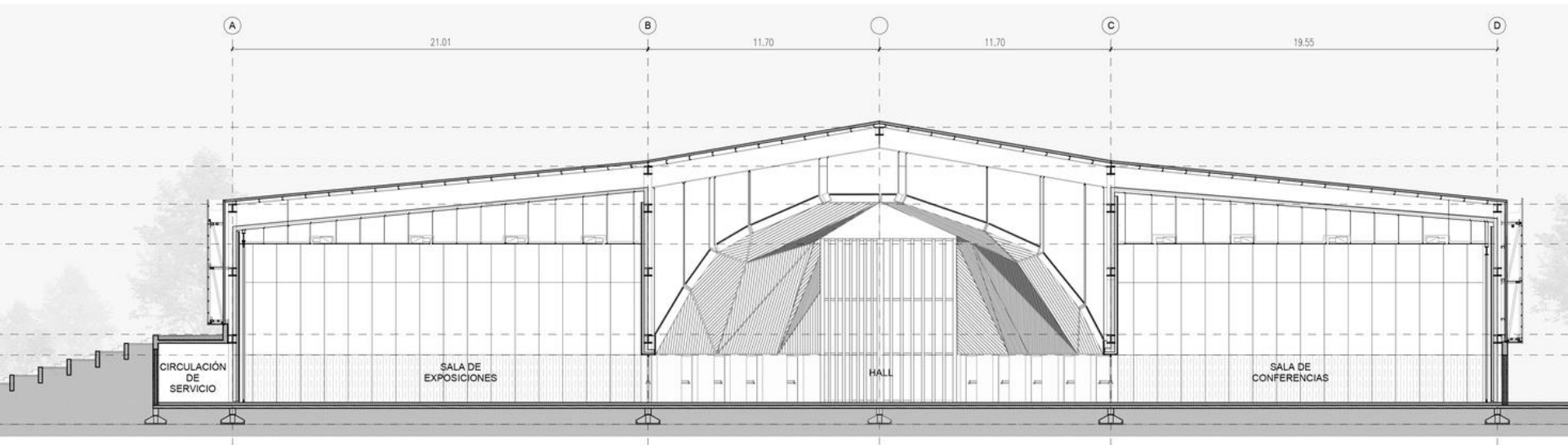

VISTA 2
1:100

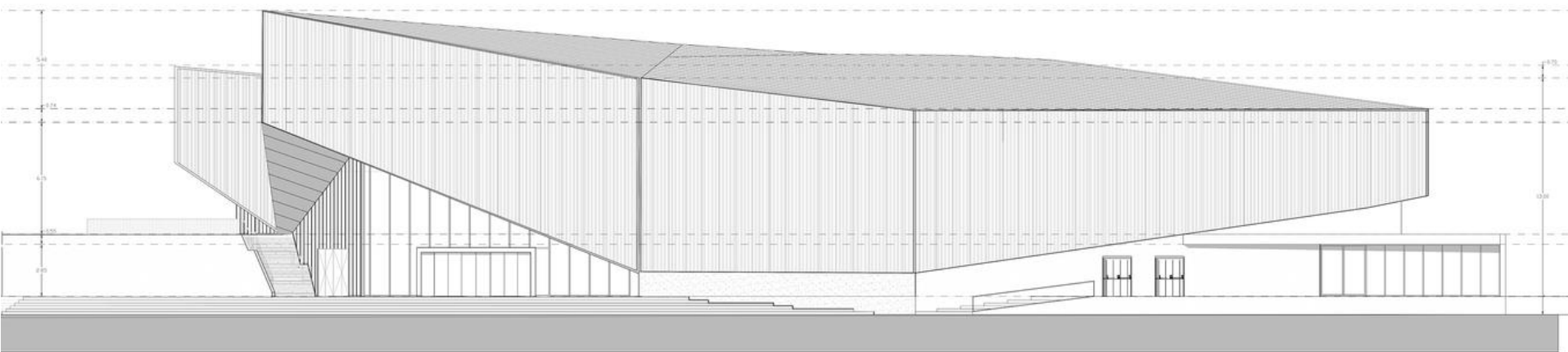

VISTA 1
1:100





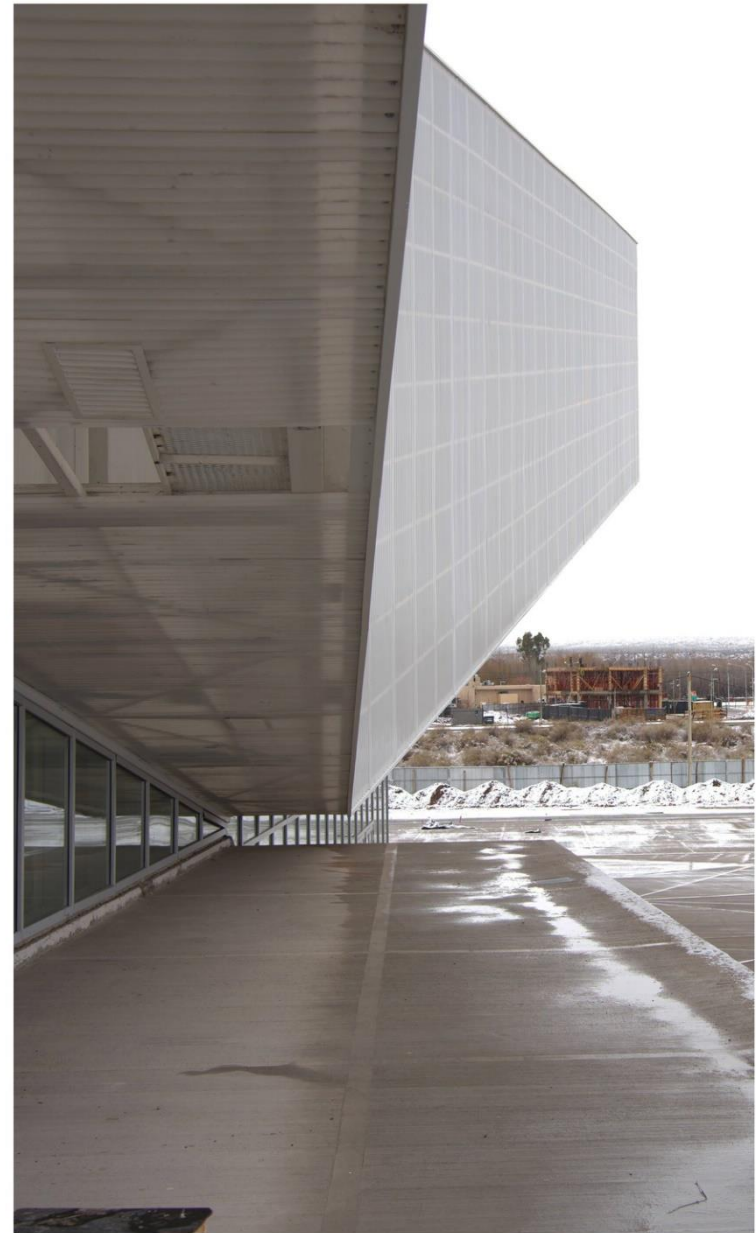
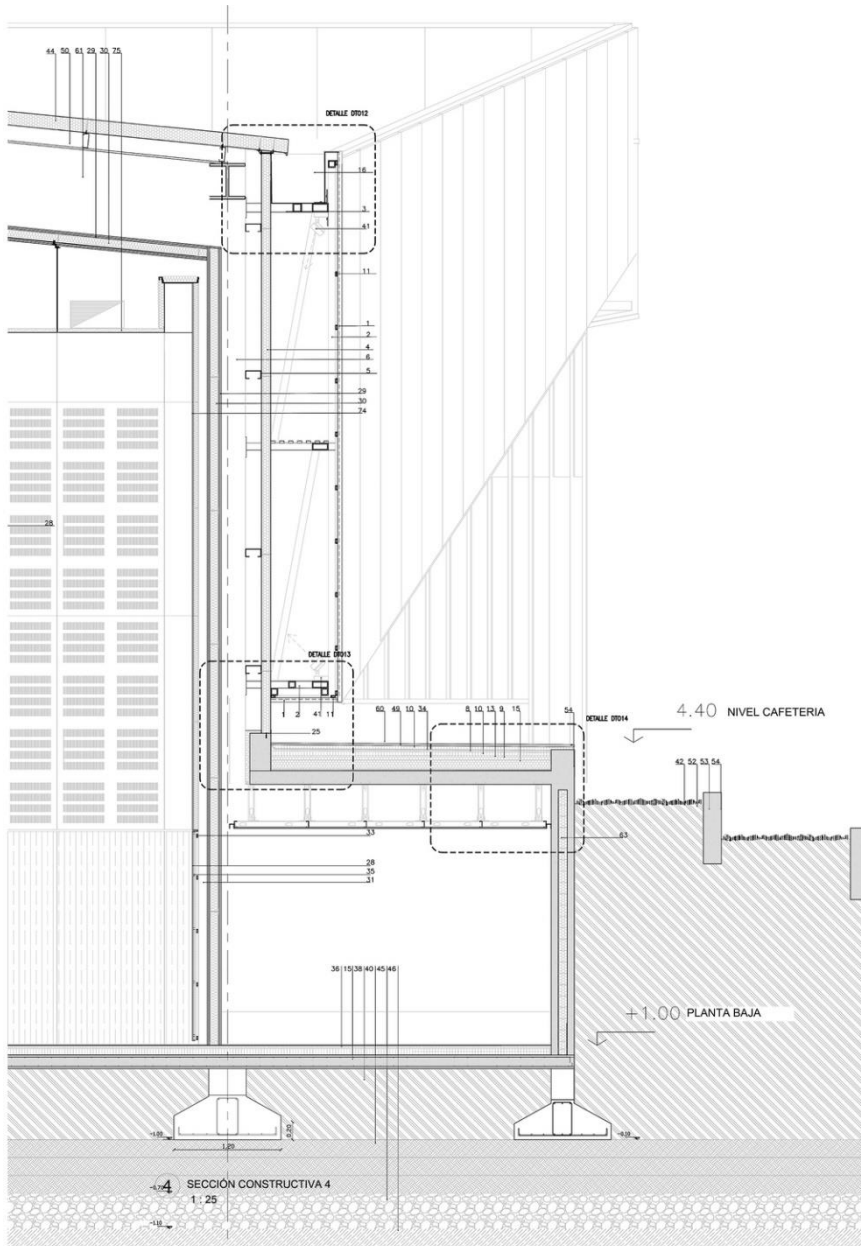

PROGRAMA DE NECESIDADES

Nº	DESIGNACIÓN	ACTIVIDADES	EQUIPAMIENTO	CANTIDAD	SUPERFICIE	%
1	Hall y recepción ppal	Recepción e informes	Mueble recepción atención al público	1,00	65,00	0,14
2	Showrrom	Exposiciones. Presentación de productos	1 y 2 pueden ser espacios unificados.	1,00		
3	Auditorio/SUM	Conferencias-Presentación de productos. Congresos	Capacidad 130 personas Butacas	2,00	200,00	0,43
4	Buffet	Cafetería-Almuerzo	Cocina - Barra -Mesada, bacha, anafe, heladera, microondas Mesa, sillas	1,00	40,00	0,09
			Deposito Buffet	1,00	7,00	0,01
5	Sala de maquinas	Servicio	Tablero general. Bombas de agua. Equipo generador	1,00	30,00	0,06
6	Sanitarios Públicos	Sanitarios caballeros Sanitarios Damas Higiene	Lavamanos Box Inodoros	2,00	30,00	0,06
7	Deposito General	Deposito enseres		1,00	15,00	0,03
8	Administración	Oficina de administración del complejo	Dos escritorios , con sillas	1,00	15,00	0,03
9	Circulación muros			1,00	65,00	0,14
	TOTAL				467,00	
10	Area exterior de ingreso				Libre	
11	Estacionamiento vehicular				Libre	