



Rexnord and Link-Belt Roller Chains

CATALOGO DE CADENAS DE TRANSMISION DE
RODILLOS

CATEDRA: MECANICA APLICADA

UNIVERSIDAD NACIONAL DE CUYO - FAC. ING.

ING. S. LAZO - ING. C. BARRERA

AÑO 2016

Section Index

Description Page

A – Introduction

Introduction A-2

B – Drive Chains

Standard Roller Chains B-1

SU and H Series Chains B-4

Double Pitch Drive Chains B-6

Extra Clearance Chains B-6

Corrosion Resistant Chains B-7

O-Ring Chains B-8

No incluido en este resumen

C – Drive Engineering

Engineering Recommendations C-1

Specifications, Dimensions and Ratings C-9

Lubrication C-45

Drive Installation C-47

No incluido en este resumen

D – Conveyor Chains

Conveyor Chains Introduction D-1

Standard Roller Chains and Attachments D-2

Double Pitch Roller Chains and Attachments D-4

Redi-Lube Chain D-8

Hollow Pin Chain D-10

Side Bow Chain D-14

Block Chain D-15

E – Conveyor Engineering

Engineering Recommendations E-1

Selection Procedure E-4

Layouts and Formulas E-6

Selection Example E-8

Lubrication E-9

Sprocket Data E-10

F – British Standard

Standard Roller Chain F-1

RC for Heavy Drives and Lifting Applications F-4

RC with Straight Link Plates F-4

RC with Thermoplastic Bearings F-5

Hollow Pin F-6

Side Bow F-7

Double Pitch Roller Chain F-8

G – General Products and Information

Specifications G-1

Sprocket Reference Data G-2

Chain and Parts Packaging G-3

Chain Parts Standards G-4

Chain Repair Tools G-5

H – Technical Data

Technical Data H-1

Chain Index H-3

A

Link-Belt and Rexnord Roller Chains

Drives

Standard roller chain is broadly used in power transmission applications ranging from general industrial applications to demanding oil field service to operation in such specialized areas as food processing and heavy construction equipment.

Single and multiple standard roller chains, available in many sizes, meet most drive requirements. Specifications are shown on pages B-1 through B-3.

Double-pitch drive chains frequently prove the economical choice for slower speed drives on relatively long centers. For details, see page B-6.

Modifications of these chains, developed for special operating conditions, are described below.

Corrosion resistance—Standard roller chain made of stainless steel provides excellent performance in applications requiring high resistance to corrosive attack. See page B-7.



Standard roller chain/single strand

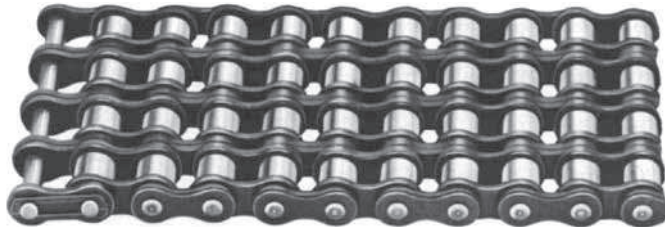

Standard roller chain/multiple strand



Double-pitch drive chain



Shock resistance - Link-Belt SU and Rexnord Heavy "H" series roller chain provides additional capacity to withstand intermittent shock loading. Features include improved fatigue resistance, thicker sidebars, and heat-treated pins. See page B-4.



Extra clearance - Trans-Flex® chain is designed for severe duty applications, such as in transit mixers, crawler drives, and other uses requiring delivery of full power despite recurrent sprocket misalignment. See page B-6.

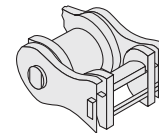

ULTR-O-LIFE™ O-ring roller chain¹ - Uses square cross sectional O-rings to seal in special lube while sealing out dirt, moisture and other contaminants. Available in 5/8" thru 1 1/4" pitch single pitch series. Runs on standard ANSI sprockets. See page B-8.



Side bow roller chain¹ - Extra clearance chain with ability to flex and twist. Ideal for use on curved conveyors or to transmit power under misaligned sprocket conditions. Available in 3/8" to 1" single pitch. See page D-15.



Block chain¹ - Used in light load, low speed conveyors. Consisting of block links (solid or laminated) and link plates joined by pins, all block chains are 1" pitch and vary in width of block from 3/16" to 1/2". See page D-16.



REDI-LUBE™ chain¹ - Self-lubricating, heavy walled, oil-impregnated, sintered steel bushings replace bushing and roller of standard ANSI chain. Available in single and double-pitch. Full range of standard attachments also available. See page D-9.



Hollow pin chain¹ - The versatile conveyor chain. Constructed with special pin links which have hollow pins assembled in the pin plates. This unique design allows easy insertion of cross rods or attachments to preassembled chain at desired spacings. Attachments can be repositioned without removing chain from conveyor. It is available in single and double-pitch with or without Carrier Rollers. Full line of standard attachments available. See page D-11.

Conveyors

Standard and double-pitch conveyor chains are available with a selection of attachments to accommodate slats, angles, rollers, crossroads, and other conveying devices. See pages D-3 through D-8.

Restricted lubrication

Double-pitch roller chain with large-diameter rollers combines smooth, quiet operation and long life. This modification proves particularly useful in applications requiring minimum lubrication or where conditions make lubrication difficult. See page D-6.

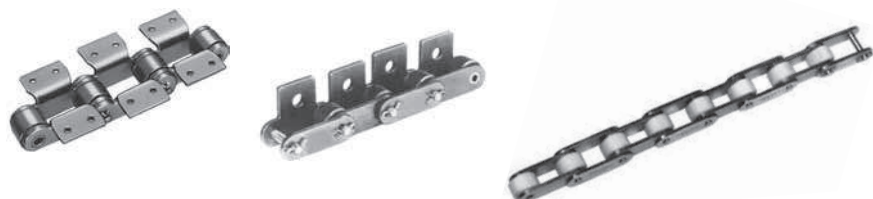

¹ Available only in Link-Belt Brand

Link-Belt and Rexnord Drive Chains

Standard roller chains

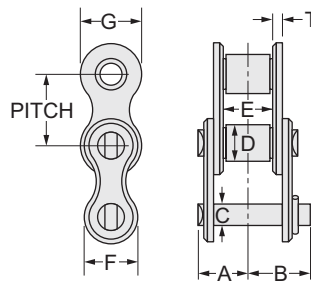

Single Strand

Chain Number	Chain pitch, inches	Average Ultimate strength, pounds	Min. ANSI UTS, pounds	Weight per foot, pounds	Dimensions, inches								Page references	
					A	B	C	D	E	F	G	T	HP ratings	Sprocket data
25 Δ	.250	940	781	.08	.15	.19	.090	.130	.13	.20	.23	.03	C-9	C-10
35 Δ	.375	2,100	1,758	.22	.24	.31	.141	.200	.19	.31	.35	.05	C-11	C-12
40 Δ	.500	3,700	3,125	.39	.32	.38	.156	.313	.31	.41	.47	.06	C-13	C-14
41 Δ	.500	2,000	1,500	.27	.27	.32	.141	.306	.25	.32	.38	.05	C-15	C-16
50 Δ	.625	6,100	4,882	.70	.41	.48	.200	.400	.38	.52	.59	.08	C-17	C-18
60	.750	8,500	7,030	1.02	.50	.60	.234	.469	.50	.60	.71	.09	C-19	C-20
80	1.000	14,500	12,500	1.67	.63	.74	.312	.625	.63	.75	.91	.13	C-21	C-22
100	1.250	26,000	19,530	2.72	.76	.89	.375	.750	.75	.97	1.13	.16	C-23	C-24
120	1.500	36,500	28,125	3.72	.96	1.13	.438	.875	1.00	1.13	1.38	.19	C-25	C-26
140	1.750	48,500	38,280	4.69	1.02	1.21	.500	1.000	1.00	1.31	1.56	.22	C-27	C-28
160	2.000	68,000	50,000	6.12	1.23	1.41	.563	1.125	1.25	1.56	1.81	.25	C-29	C-30
180	2.250	86,000	63,280	9.06	1.39	1.56	.688	1.406	1.41	1.85	2.14	.28	C-31	C-32
200	2.500	100,000	78,125	10.9	1.54	1.89	.781	1.563	1.50	1.94	2.31	.31	C-33	C-34
240	3.000	152,200	112,500	16.4	1.85	2.20	.938	1.875	1.88	2.44	2.81	.38	C-35	C-36

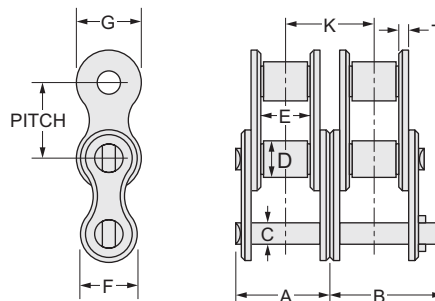

Double Strand

Chain Number	Chain pitch, inches	Average Ultimate strength, pounds	Min. ANSI UTS, pounds	Weight per foot, pounds	Dimensions, inches								Page references		
					A	B	C	D	E	F	G	K	T	HP ratings	Sprocket data
35-2 Δ	.375	4,200	3,516	.42	.45	.50	.141	.200 ▲	.19	.31	.35	.399	.05	C-11	C-12
40-2 Δ	.500	7,400	6,250	.79	.60	.67	.156	.313	.31	.41	.47	.566	.06	C-13	C-14
50-2 Δ	.625	12,200	9,764	1.39	.76	.83	.200	.400	.38	.52	.59	.713	.08	C-17	C-18
60-2	.750	17,000	14,060	2.00	.95	1.05	.234	.469	.50	.60	.71	.897	.09	C-19	C-20
80-2	1.000	29,000	25,000	3.31	1.21	1.30	.312	.625	.63	.75	.91	1.153	.13	C-21	C-22
100-2	1.250	52,000	39,060	5.19	1.46	1.59	.375	.750	.75	.97	1.13	1.408	.16	C-23	C-24
120-2	1.500	73,000	56,250	7.38	1.84	2.02	.438	.875	1.00	1.13	1.38	1.789	.19	C-25	C-26
140-2	1.750	97,000	76,560	9.25	1.98	2.17	.500	1.000	1.00	1.31	1.56	1.924	.22	C-27	C-28
160-2	2.000	136,000	100,000	12.5	2.38	2.56	.563	1.125	1.25	1.56	1.81	2.305	.25	C-29	C-30
180-2	2.250	172,000	126,560	17.6	2.69	2.86	.688	1.406	1.41	1.85	2.14	2.592	.28	C-31	C-32
200-2	2.500	200,000	156,250	21.0	2.96	3.31	.781	1.563	1.50	1.94	2.31	2.817	.31	C-33	C-34
240-2	3.000	304,400	225,000	32.2	3.58	3.93	.938	1.875	1.88	2.44	2.81	3.458	.38	C-35	C-36

Δ Available only in riveted construction. All other sizes may be furnished cottered or riveted.
 ▲ Bushing diameter. Chain is rollerless.

B

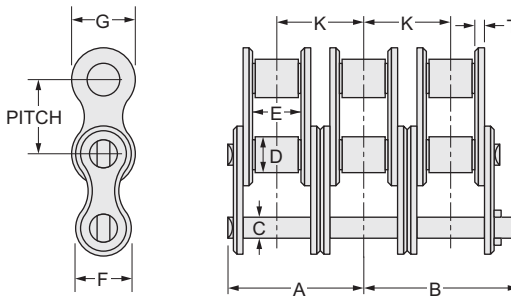

Fig. 6446

Triple Strand

Chain Number	Chain pitch, inches	Average Ultimate strength, pounds	Min. ANSI UTS, pounds	Weight per foot, pounds	Dimensions, inches									Page references	
					A	B	C	D	E	F	G	K	T	HP ratings	Sprocket data
35-3	.375	6,300	5,274	.62	.63	.70	.141	.200 ▲	.19	.31	.35	.399	.05	C-11	C-12
40-3 Δ	.500	11,100	9,375	1.18	.89	.95	.156	.313	.31	.41	.47	.566	.06	C-13	C-14
50-3 Δ	.625	18,300	14,646	2.09	1.12	1.19	.200	.400	.38	.52	.59	.713	.08	C-17	C-18
60-3	.750	25,500	21,090	3.00	1.40	1.50	.234	.469	.50	.60	.71	.897	.09	C-19	C-20
80-3	1.000	43,500	37,500	4.97	1.78	1.87	.312	.625	.63	.75	.91	1.153	.13	C-21	C-22
100-3	1.250	78,000	58,590	7.67	2.16	2.29	.375	.750	.75	.97	1.13	1.408	.16	C-23	C-24
120-3	1.500	109,500	84,375	11.0	2.74	2.91	.438	.875	1.00	1.13	1.38	1.789	.19	C-25	C-26
140-3	1.750	145,500	114,840	13.8	2.94	3.13	.500	1.000	1.00	1.31	1.56	1.924	.22	C-27	C-28
160-3	2.000	204,000	150,000	18.6	3.52	3.71	.563	1.125	1.25	1.56	1.81	2.305	.25	C-29	C-30
180-3	2.250	258,000	189,840	26.9	3.98	4.15	.688	1.406	1.41	1.85	2.14	2.592	.28	C-31	C-32
200-3	2.500	300,000	234,375	31.5	4.38	4.73	.781	1.563	1.50	1.94	2.31	2.817	.31	C-33	C-34
240-3	3.000	456,600	337,500	49.4	5.31	5.75	.938	1.875	1.88	2.44	2.81	3.458	.38	C-35	C-36

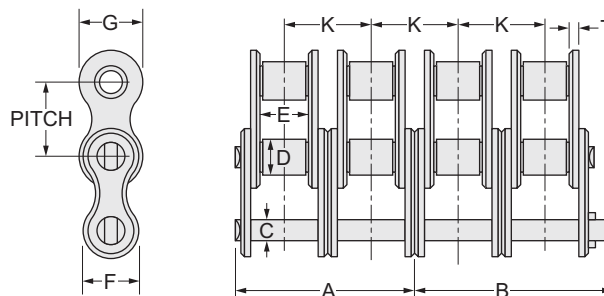

Fig. 6447

Quadruple Strand

Chain Number	Chain pitch, inches	Average Ultimate strength, pounds	Min. ANSI UTS, pounds	Weight per foot, pounds	Dimensions, inches									Page references	
					A	B	C	D	E	F	G	K	T	HP ratings	Sprocket data
35-4 Δ	.375	8,400	7,032	.82	.78	.91	.141	.200 ▲	.19	.31	.35	.399	.05	C-11	C-12
40-4 Δ	.500	14,800	12,500	1.57	1.17	1.23	.156	.313	.31	.41	.47	.566	.06	C-13	C-14
50-4 Δ	.625	24,400	19,528	2.76	1.48	1.54	.200	.400	.38	.52	.59	.713	.08	C-17	C-18
60-4	.750	34,000	28,120	3.83	1.84	1.95	.234	.469	.50	.60	.71	.897	.09	C-19	C-20
80-4	1.000	58,000	50,000	6.76	2.35	2.44	.312	.625	.63	.75	.91	1.153	.13	C-21	C-22
100-4	1.250	104,000	78,120	10.1	2.86	2.99	.375	.750	.75	.97	1.13	1.408	.16	C-23	C-24
120-4	1.500	146,000	112,500	14.7	3.63	3.81	.438	.875	1.00	1.13	1.38	1.789	.19	C-25	C-26
140-4	1.750	194,000	153,120	18.4	3.90	4.09	.500	1.000	1.00	1.31	1.56	1.924	.22	C-27	C-28
160-4	2.000	272,000	200,000	24.8	4.67	4.86	.563	1.125	1.25	1.56	1.81	2.305	.25	C-29	C-30
180-4	2.250	344,000	253,120	35.8	5.28	5.45	.688	1.406	1.41	1.85	2.14	2.592	.28	C-31	C-32
200-4	2.500	400,000	312,500	43.2	5.80	6.14	.781	1.563	1.50	1.94	2.31	2.817	.31	C-33	C-34
240-4	3.000	608,800	450,000	65.7	7.04	7.38	.938	1.875	1.88	2.44	2.81	3.458	.38	C-35	C-36

Δ Available only in riveted construction. All other sizes may be furnished cottered or riveted.
 ▲ Bushing diameter. Chain is rollerless.

Link-Belt and Rexnord Drive Chains

Standard roller chains

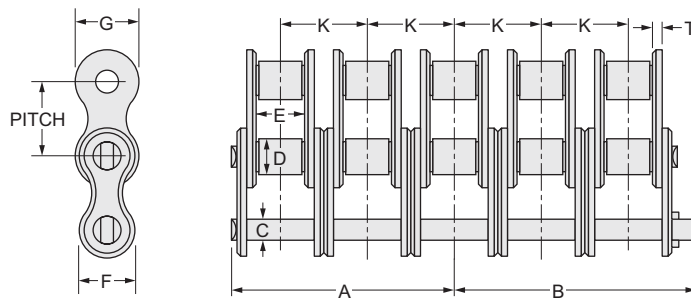

Fig. 6448

Quintuple Strand

Chain Number	Chain pitch, inches	Average Ultimate strength, pounds	Min. ANSI UTS, pounds	Weight per foot, pounds	Dimensions, inches										Page references	
					A	B	C	D	E	F	G	K	T	HP ratings	Sprocket data	
35-5 Δ	.375	10,500	8,790	1.06	1.03	1.11	.141	.200 ▲	.19	.31	.35	.399	.05	C-11	C-12	
40-5 Δ	.500	18,500	15,625	1.97	1.45	1.52	.156	.313	.31	.41	.47	.566	.06	C-13	C-14	
50-5 Δ	.625	30,500	24,410	3.15	1.84	1.90	.200	.400	.38	.52	.59	.713	.08	C-17	C-18	
60-5	.750	42,500	35,150	5.02	2.30	2.40	.234	.469	.50	.60	.71	.897	.09	C-19	C-20	
80-5	1.000	72,500	62,500	8.21	2.92	3.03	.313	.625	.63	.75	.91	1.153	.13	C-21	C-22	
100-5	1.250	130,000	97,650	12.7	3.56	3.69	.375	.750	.75	.97	1.13	1.408	.16	C-23	C-24	
120-5	1.500	182,500	140,625	18.4	4.52	4.70	.438	.875	1.00	1.13	1.38	1.789	.19	C-25	C-26	
140-5	1.750	242,500	191,400	22.9	4.86	5.05	.500	1.000	1.00	1.31	1.56	1.924	.22	C-27	C-28	
160-5	2.000	340,000	250,000	31.9	5.82	6.00	.563	1.125	1.25	1.56	1.81	2.305	.25	C-29	C-30	
180-5	2.250	430,000	316,400	44.7	6.57	6.74	.688	1.406	1.41	1.85	2.14	2.592	.28	C-31	C-32	
200-5	2.500	500,000	390,625	53.9	7.22	7.56	.781	1.563	1.50	1.94	2.31	2.817	.31	C-33	C-34	
240-5	3.000	761,000	562,500	82.0	8.76	9.11	.938	1.875	1.88	2.44	2.81	3.458	.38	C-35	C-36	

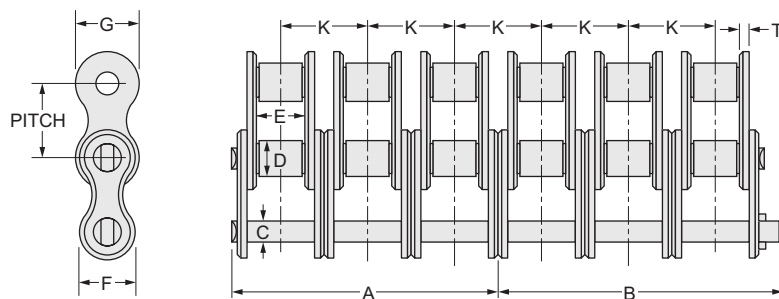

Fig. 6449

Sextuple Strand

Chain Number	Chain pitch, inches	Average Ultimate strength, pounds	Min. ANSI UTS, pounds	Weight per foot, pounds	Dimensions, inches										Page references	
					A	B	C	D	E	F	G	K	T	HP ratings	Sprocket data	
35-6 Δ	.375	12,600	10,548	1.27	1.23	1.31	.141	.200 ▲	.19	.31	.35	.399	.05	C-11	C-12	
40-6 Δ	.500	22,200	18,750	2.36	1.73	1.80	.156	.313	.31	.41	.47	.566	.06	C-13	C-14	
50-6 Δ	.625	36,600	29,292	3.77	2.19	2.25	.200	.400	.38	.52	.59	.713	.08	C-17	C-18	
60-6	.750	51,000	42,180	6.02	2.75	2.85	.234	.469	.50	.60	.71	.897	.09	C-19	C-20	
80-6	1.000	87,000	75,000	9.84	3.50	3.61	.313	.625	.63	.75	.91	1.153	.13	C-21	C-22	
100-6	1.250	156,000	117,180	15.2	4.26	4.39	.375	.750	.75	.97	1.13	1.408	.16	C-23	C-24	
120-6	1.500	219,000	168,750	22.0	5.42	5.59	.438	.875	1.00	1.13	1.38	1.789	.19	C-25	C-26	
140-6	1.750	291,000	229,680	27.4	5.82	6.01	.500	1.000	1.00	1.31	1.56	1.924	.22	C-27	C-28	
160-6	2.000	408,000	300,000	38.3	6.97	7.15	.563	1.125	1.25	1.56	1.81	2.305	.25	C-29	C-30	
180-6	2.250	516,000	379,680	53.6	7.87	8.04	.688	1.406	1.41	1.85	2.14	2.592	.28	C-31	C-32	
200-6	2.500	600,000	468,750	64.6	8.64	8.98	.781	1.563	1.50	1.94	2.31	2.817	.31	C-33	C-34	
240-6	3.000	913,200	675,000	98.4	10.50	10.84	.938	1.875	1.88	2.44	2.81	3.458	.38	C-35	C-36	

Δ Available only in riveted construction. All other sizes may be furnished cottered or riveted.

▲ Bushing diameter. Chain is rollerless.

Minimum order quantities may be required in some parts.

B

SU (Super Ultimate) and H (Heavy) Series Chains

Link-Belt SU and Rexnord H series chains differ from standard roller chains in sidebar thickness and in pin material and heat treatment. The combination of increased sidebar thickness and high hardness alloy through hardened pins results in greater average ultimate tensile strength ratings for the SU and H series chains. The SU and H chains are capable of withstanding higher operating and intermittent shock loading without reduction of pin-bushing wear life.

Multiple width SU and H series chains are available.

SU and H series single strand roller chains operate on standard series roller chain sprockets. However, multiple strand heavy series chains require sprockets with rows of teeth with wider spacing to accommodate the thicker chain sidebars. See page B-5.

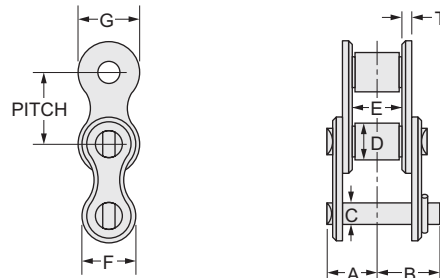

Fig. 6453

SU series

Chain Number		Chain pitch, inches	Average Ultimate strength, pounds	Joint bearing area, square inches	Weight per foot, pounds	Dimensions, inches								Page references
Link-Belt	Rexnord					A	B	C	D	E	F	G	T	Sprocket data
60H Δ	60H Δ	.750	8,500	.176	1.23	.56	.65	.234	.469	.50	.60	.69	.13	C-20
80SU	80H	1.000	17,500	.295	1.95	.69	.81	.313	.625	.63	.75	.91	.16	C-22
100SU	100H	1.250	29,000	.427	2.84	.83	.95	.375	.750	.75	.97	1.13	.19	C-24
120SU	120H	1.500	41,000	.636	4.14	1.02	1.19	.438	.875	1.00	1.13	1.38	.22	C-26
140SU	140H	1.750	56,000	.759	5.17	1.08	1.27	.500	1.000	1.00	1.31	1.56	.25	C-28
160SU	160H	2.000	70,000	1.028	6.92	1.29	1.47	.563	1.125	1.16	1.56	1.81	.28	C-30
180SU	180H	2.250	95,000	1.413	9.54	1.45	1.62	.688	1.406	1.41	1.85	2.14	.31	C-32
264 \blacksquare	64S	2.500	135,000	2.023	12.45	1.674	2.018	.875	1.562	1.50	2.05	2.38	.38	C-34

Δ Case hardened pin. 60

\blacksquare Replaces 250S and runs on 200 sprockets. Have dimensions certified for installation purposes.

Sprocket Tooth Profile - Heavy Series Roller Chain

Single strand heavy series roller chain can be used with ANSI standard series roller chain sprockets of corresponding pitch. However, multiple strand heavy series roller chain **cannot** be used with the standard series sprockets, because of the extra thickness of link plates on the heavy series. Sprockets for multiple strand heavy series roller chain must be made to order.

Single Strand

Dimensions, inches					
Chain No.	Pitch	B	E	F	R
60H	.750	0.459	0.375	0.272	0.796
80SU	1.000	0.575	0.500	0.325	1.062
100SU	1.250	0.692	0.625	0.380	1.327
120SU	1.500	0.924	0.750	0.549	1.593
140SU	1.750	0.924	0.875	0.487	1.858
160SU	2.000	1.156	1.000	0.656	2.124
180SU	2.250	1.301	1.125	0.740	2.392
264	2.500	1.389	1.250	0.764	2.654

SINGLE

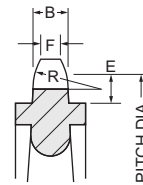

Double Strand

Dimensions, inches							
Chain No.	Pitch	A	B	D	E	F	G
60H-2	.750	1.471	0.444	0.583	0.375	0.257	1.027
80SU-2	1.000	1.839	0.556	0.727	0.500	0.306	1.283
100SU-2	1.250	2.210	0.670	0.870	0.625	0.358	1.540
120SU-2	1.500	2.820	0.894	1.032	0.750	0.519	1.926
140SU-2	1.750	2.949	0.894	1.161	0.875	0.457	2.055
160SU-2	2.000	3.555	1.119	1.317	1.000	0.619	2.436
180SU-2	2.250	4.248	1.259	1.730	1.125	0.700	2.989
264-2	2.500	4.426	1.344	1.738	1.250	0.719	3.082

DOUBLE

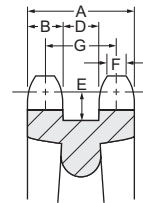

Triple Strand

Dimensions, inches							
Chain No.	Pitch	A	B	D	E	F	G
60H-3	.750	2.498	0.444	0.583	0.375	0.257	1.027
80SU-3	1.750	3.122	0.556	0.727	0.500	0.306	1.283
100SU-3	1.250	3.750	0.670	0.870	0.625	0.358	1.540
120SU-3	1.500	4.746	0.894	1.032	0.750	0.519	1.926
140SU-3	1.750	5.004	0.894	1.161	0.875	0.457	2.055
160SU-3	2.000	5.991	1.119	1.317	1.000	0.619	2.436
180SU-3	2.250	7.237	1.259	1.730	1.125	0.700	2.989
264-3	2.500	7.508	1.344	1.738	1.250	0.719	3.082

TRIPLE

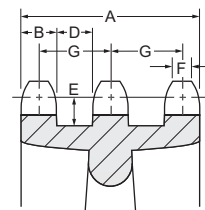

Quadruple Strand

Dimensions, inches							
Chain No.	Pitch	A	B	D	E	F	G
60H-4	.750	3.499	0.418	0.609	0.375	0.231	1.027
80SU-4	1.000	4.375	0.526	0.757	0.500	0.276	1.283
100SU-4	1.250	5.253	0.633	0.907	0.625	0.321	1.540
120SU-4	1.500	6.626	0.848	1.078	0.750	0.473	1.926
140SU-4	1.750	7.013	0.848	1.207	0.875	0.411	2.055
160SU-4	2.000	8.371	1.063	1.373	1.000	0.563	2.436
180SU-4	2.250	10.170	1.203	1.786	1.125	0.640	2.989
264-4	2.500	10.524	1.278	1.804	1.250	0.653	3.082

QUADRUPLE

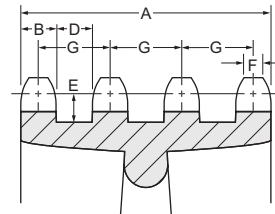

Drive Engineering Engineering recommendations

Several drive selections can usually be made for a given application. Consideration of life expectancy, space, speed, cost and similar factors often suggest the better selection.

Use the following recommendations as a guide when selecting roller chain drives.

Horsepower ratings The horsepower ratings listed on pages C-9 to C-35 apply directly to lubricated, single strand, standard and heavy series roller chains. Multiple strand chains are selected from the same rating tables by applying the factors in Table 2, page C-7. Stainless steel chain and other variations of standard roller chain are also selected from the rating tables by applying the appropriate material or design variation factor from Table 3, page C-7.

Chain pitch Use the smallest pitch chain that will handle the horsepower and load requirements. Single strand chains satisfy most requirements and are usually more economical. Use small pitch multiple strand chains for high speed drives or when quietness is desirable. This permits a larger number of teeth in the driver sprocket and results in smoother drive operation.

Number of teeth for small sprockets The recommended minimum number of teeth for the small sprocket varies with operating conditions. The recommended minimums are:

- Very slow speed drives 12 teeth
- Slow speed drives 17 teeth
- Moderate speed drives 21 teeth
- High speed drives 25 teeth

Hardened teeth It is good practice to harden sprockets with 25 teeth or less when applied to:

- Very low speed, heavily loaded drives
- High speed drives
- Large ratio drives
- Abrasive or corrosive conditions

For additional information, consult Rexnord.

Chart A Variations in chain speed due to chordal action

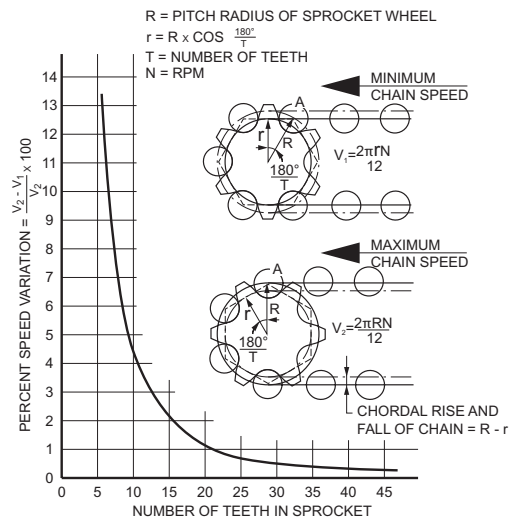

Chordal action The rise and fall of each pitch of chain as it engages a sprocket is termed chordal action and causes repeated chain speed variations. As illustrated by chart A, chordal action and speed variation decrease as the number of teeth in the small sprocket is increased. Chordal action becomes negligible when 25 or more teeth are used and results in smoother drive operation.

Quietness Speed and horsepower usually determine chain pitch. When quietness is essential, select a smaller pitch, wider chain and a driver sprocket with at least 25 teeth.

Number of teeth for large sprockets The number of teeth in the large sprocket has an appreciable effect on the amount of joint wear (or pitch elongation) that can be accommodated by the chain before it tends to jump or ride over the teeth. This is illustrated by Chart B. Generally, a roller chain has reached its useful wear life when the elongation per pitch is in the range of 2% to 3% of pitch. As show in the chart, this would result in a maximum of 65-100 teeth for the large sprocket. This suggested maximum can be exceeded by making a more conservative chain selection.

When space limits the diameter of the large sprocket, it may be necessary to select a smaller pitch, multiple strand chain to provide a sufficient number of teeth for the small sprocket.

Drive ratio The drive ratio is determined by the speeds of the driving and driven shafts. Properly engineered, drives with ratios up to 10:1 will perform satisfactorily. However, double-reduction drives with smaller ratios have better operating characteristics and are often more economical than a large ratio, single-reduction drive.

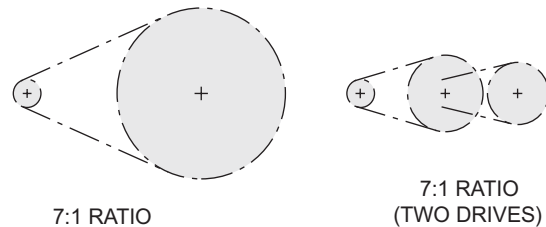
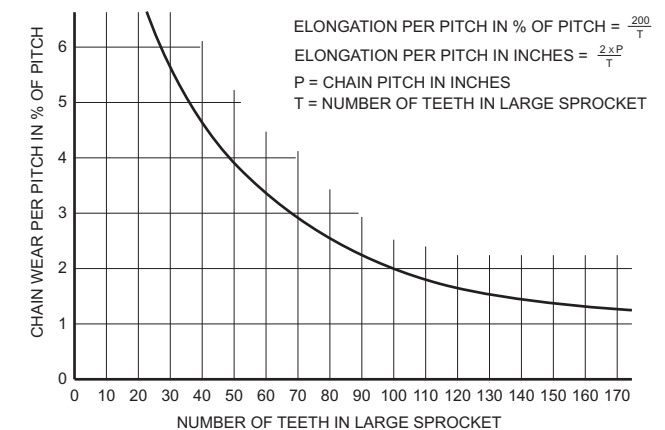
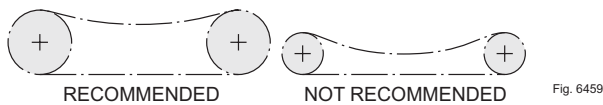

Chart B Variations in useful chain life based on pitch elongation and number of teeth in large sprocket



C

Select relatively large diameter sprockets for 1:1 and 2:1 ratio drives, especially if required to operate on horizontal centers. This will assure adequate distance between the two spans of chain and prevent them from striking as wear accumulates. This is particularly important for drives on long, fixed centers with the slack chain span on top.



Small pitch, multiple strand chains are generally more economical for large ratio drives on minimum centers. Large pitch, single strand chains are usually most economical for small ratio drives on long centers.

Center distance Sprocket centers must be more than 1/2 the sum of the sprocket outside diameters to avoid tooth interference.

A suggested minimum center distance would equal the diameter of the large sprocket plus half the diameter of the small sprocket. Drives so proportioned also assure the minimum suggested chain wrap of 120° on the small sprocket.

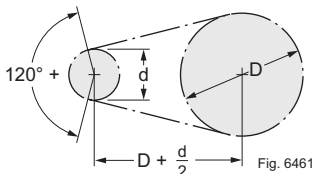

Chain tension To obtain maximum chain life, make provisions to maintain proper chain tension. Make an initial adjustment after approximately the first 100 hours of operation to remove slack caused by initial elongation. Thereafter, the frequency of periodic adjustments is governed by operating conditions.

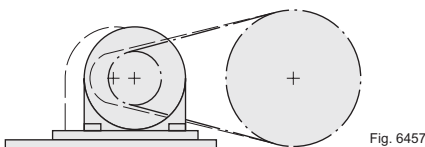

The simplest method of adjusting chain tension is to provide for movement of one shaft. This method is commonly used for drives operating from electric motors or internal combustion engines since they can be mounted on adjustable baseplates or slide rails.

For fixed center drives, chain tension may be maintained by an automatic or manually adjusted chain tightener. Manually operated chain tighteners must be frequently checked for proper adjustment.

The idler sprocket should have a minimum of 17 teeth and should be located adjacent to the driving sprocket so that at least 3 teeth are in full engagement with the non-load-carrying span of chain.

If possible, provide enough adjustment of the chain tightener to permit removal of two pitches of chain.

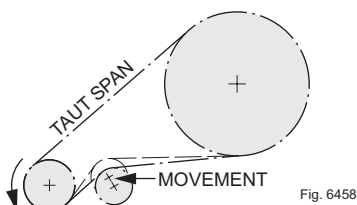

Typical drive arrangements using chain tighteners are shown in the preferred drive arrangements below.

Offset links may be used to adjust chain length when other means are not available. Single-pitch offset links and two-pitch offset assemblies can be supplied. Offset assemblies are recommended for high speed or heavily loaded drives.

Chain tension should be carefully maintained when the following operating conditions exist:

- Fixed centers
- Vertical or near vertical centers
- Shock or pulsating loads
- Reversals in direction of rotation

Chain length When possible use a chain length with an even number of pitches to eliminate the need for an offset link

Fixed centers When sprocket centers cannot be adjusted, make a conservative drive selection by using a larger service factor than indicated. Also, provide good lubrication.

Low speed drives Ratings are not shown in the horsepower tables for extremely low speeds. For operation at these speeds, select drives on a chain strength basis. The ratio of ultimate chain strength to working load should be at least 6:1.

Drives that operate at varying speeds such as power take-off drives from a torque converter, from an engine with a multi-speed gear transmission, or from a constant horsepower, variable speed electric motor, should be selected on a chain strength basis. The ratio of ultimate strength to maximum peak load should not be less than 6:1. The selection should be checked against the horsepower table for sufficient rating at the normal operating speed.

Drives operating from variable speed, variable horsepower electric motors should be selected to meet the maximum load requirements. In selecting the chain pitch, consideration must be given to the range of speeds involved.

Preferred drive arrangements The drive arrangements illustrated below are desirable for optimum life of the drive. The preferred direction of rotation is indicated for each arrangement, although arrangements A, B and C will operate satisfactorily in either direction.

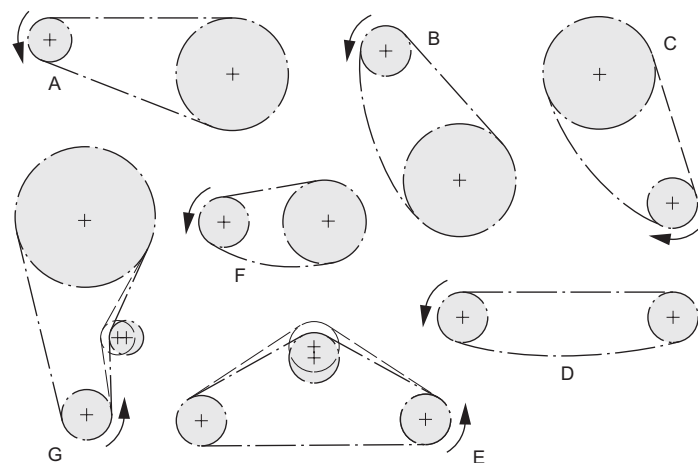

Fig. 6455

Drive Engineering

Other arrangements These arrangements are not generally recommended but they will give satisfactory service if carefully attended and chain tension is accurately maintained.

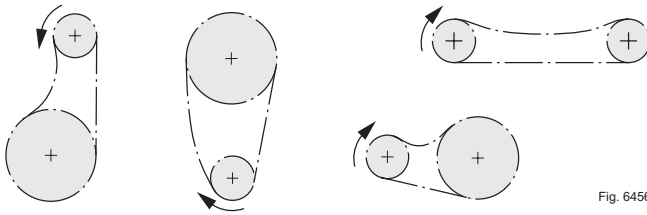

Fig. 6456

Operating conditions The service factors listed in Table 1 page C-7 are for normal operating conditions. Increase these service factors to compensate for any of the following conditions:

- Heavy starting loads
- Frequent starts and stops
- Lubrication inferior to method recommended
- Short or fixed centers
- Vertical centers, particularly if the small sprocket is in the low position
- Two or more driven shafts
- Periodic load variation in a single revolution
- Reversals of drive rotation
- Inertia strains
- Large ratios

Lubrication Adequate lubrication is necessary for optimum drive life. A general guide to the recommended method of lubrication is indicated in the horsepower rating tables. These recommendations are based primarily on chain speed. For complete lubrication data, refer to pages C-45 and C-46.

Useful formulas Formulas for calculating horsepower, torque, chain speed, working load and similar values are given on page H-1.

Drive selection procedure

Although horsepower and speed are the prime considerations for selecting a drive, the following information is also necessary:

- Source of power
- Horsepower to be transmitted
- Size and speed of driving shaft
- Driven equipment
- Size and speed of driven shaft
- Approximate center distance between shafts
- Relative position of shafts
- Space limitations

With this information the selection procedure is as follows:

Establish the service factor Select a service factor from Table 1, page C-7, to compensate for the loads imposed on the chain by the type of input power and the type of equipment to be driven. If the exact driven equipment is not listed, use the factor for equipment with similar operating characteristics. Increase the service factor, if necessary, in accordance with the instructions under "Operating Conditions" above.

Establish the material or design variation factor When a variation of standard roller chain is being selected (such as stainless steel chain for corrosion resistance), refer to Table 3 on page C-7 and determine the appropriate variation factor. This factor compensates for either the design or material difference so that a selection can be made from the standard roller chain rating table.

Calculate the equivalent horsepower Multiply the horsepower to be transmitted by the service factor (and by the variation factor, if applicable). This product is the equivalent horsepower or the value on which the chain selection is based.

Select a trial chain Standard roller chains are most commonly used and are selected from Chart C, page C-5. Single strand chains satisfy most drive requirements; however, multiple strand chains are often required for high speed drives, where space limits sprocket diameters, or where horsepower requirements exceed the capacity of single strand chains.

Double-pitch chains are often used for slow speed, comparatively low horsepower drives on long centers. Use Chart D, page C-6, to make a trial chain selection.

To make a tentative chain selection, project a horizontal line from the horsepower scale and a vertical line from the speed scale based on the equivalent horsepower and the RPM of the small sprocket. The area in which the two lines intersect indicates the probable chain requirement.

It is often desirable to evaluate selections based on the next smaller or next larger chain size, especially if the point of intersection is near the border of an area.

Determine the number of teeth for the small sprocket

The ratings in the horsepower tables apply to single strand chains.

If a single strand standard roller chain or a double-pitch roller chain has been tentatively selected, refer directly to the horsepower rating table for the trial chain (see pages C-9 to C-43). In the column corresponding to the RPM of the small sprocket, find the rating nearest to the equivalent horsepower. Follow this line horizontally to the left to find the number of teeth required for the small sprocket.

If a single multiple strand trial chain has been selected, the required rating per strand must be determined in order to use the rating tables. The required table rating per strand is calculated by dividing the equivalent horsepower by the appropriate multiple strand factor from Table 2, page C-7.

Now, refer to the horsepower rating table for the trial chain. In the column corresponding to the RPM of the small sprocket, find the rating nearest to the required rating per strand just calculated. Follow this line horizontally to the left to find the number of teeth for the small sprocket.

Check the small sprocket Check the bore capacity of the sprocket selected, making sure it will accommodate the driving shaft. If the initial selection does not have adequate bore capacity, use a sprocket with larger number of teeth, or select a drive using the next larger pitch of chain.

Determine the drive ratio Divide the speed of the faster turning shaft by the speed of the slower turning shaft.

Determine the number of teeth for the large sprocket

Multiply the drive ration by the number of teeth in the small sprocket.

If the drive is to operate in a restricted location, check the sprocket radii against the space limitation. Radial clearance required for each sprocket is equal to one-half the sum of its pitch diameter and the chain pitch. Encased drives require an additional 3" radial clearance. If sufficient space is not available, consider a smaller pitch, multiple strand drive.

Calculate exact center distance and chain length Formulas for these calculations are on page C-8.

Lubrication The methods of lubrication shown in the horsepower rating tables are based primarily on chain speed; however, the relative position of driving and driven shafts often influence the method of lubrication. Recommendations and complete lubrication information are given on pages C-45 and C-46.

Drive selection example**Problem**

Select a roller chain drive for the following conditions:

Source of power	Gearmotor
Horsepower to be transmitted	10 HP
Size of driving shaft	2.438" diameter
Speed of driving shaft	100 RPM
Driven equipment	Bucket elevator uniformly fed
Size of driven shaft	2.938" diameter
Speed of driven shaft	42 RPM
Approximate center distance	24.00"
Relative position of shafts	On same horizontal plane
Space limitations	None

Solution

Service factor The service factor listed in Table 1 on page C-7 for a uniformly fed bucket elevator driven by a gearmotor is 1.0.

Material or design variation factor Since the listed conditions do not indicate the need for a variation in chain material or design, select a standard roller chain. Therefore, a variation factor does not apply.

Equivalent horsepower The equivalent horsepower equals: $10 \times 1.0 = 10 \text{ HP}$

Trial Chain From Chart C, page C-5, note that the intersection of the 100 RPM vertical line and the 10 HP horizontal line falls in the area for No. 100 chain. Thus, the trial chain is No. 100 single strand.

Small sprocket In the No. 100 rating table, page C-23, the 100 RPM column lists 10.3 horsepower which corresponds closely to the equivalent horsepower of 10 required for this application. This rating is for single strand chain when used with a 17-tooth sprocket.

Check the small sprocket As shown in the rating table, the maximum bore of a 17-tooth No. 100 sprocket is larger than the 2.438" bore required; therefore, the selection is satisfactory. Stock sprockets are readily available and are often more economical.

Drive ratio The drive ratio equals:

$$\frac{100 \text{ RPM}}{42 \text{ RPM}} = 2.38 \text{ to } 1$$

Number of teeth in large sprocket The number of teeth in the large sprocket equals: $2.38 \times 17 = 40.4$ teeth. Use a 40-tooth sprocket.

Center distance and chain length Using the formula on page C-8, calculate the chain length as follows:

$$A = \frac{15.932 - 6.803}{2 \times 24} = .19000$$

From Table 4, page C-8, select the next higher listed value of .19081 for A. Corresponding factors for B, C and D are 1.9633, .4389, and .5611, respectively. The chain length in pitches equals:

$$\frac{1.9633 \times 24}{1.25} + (.4389 \times 17) + (.5611 \times 40) \times 1.25 = 67.601$$

Use 68 pitches, which is the nearest even number.

Calculate the exact center distance, using 68 pitches:

$$E = \frac{68 - (.4389 \times 17) - (.5611 \times 40) \times 1.25}{1.9633} = 24.254"$$

Lubrication The No. 100 rating table specifies Type B bath or disc lubrication. For lubrication and bathing details, see pages C-45 to C-46.

The drive selected for this application consists of:

17-tooth No. 100 driving sprocket
40-tooth No. 100 driven sprocket
68 pitches of No. 100 roller chain for 24.254" shaft centers, and an oil-retaining casing for oil bath lubrication.

Drive Engineering Chart

Chart C Trail selection of standard roller chains

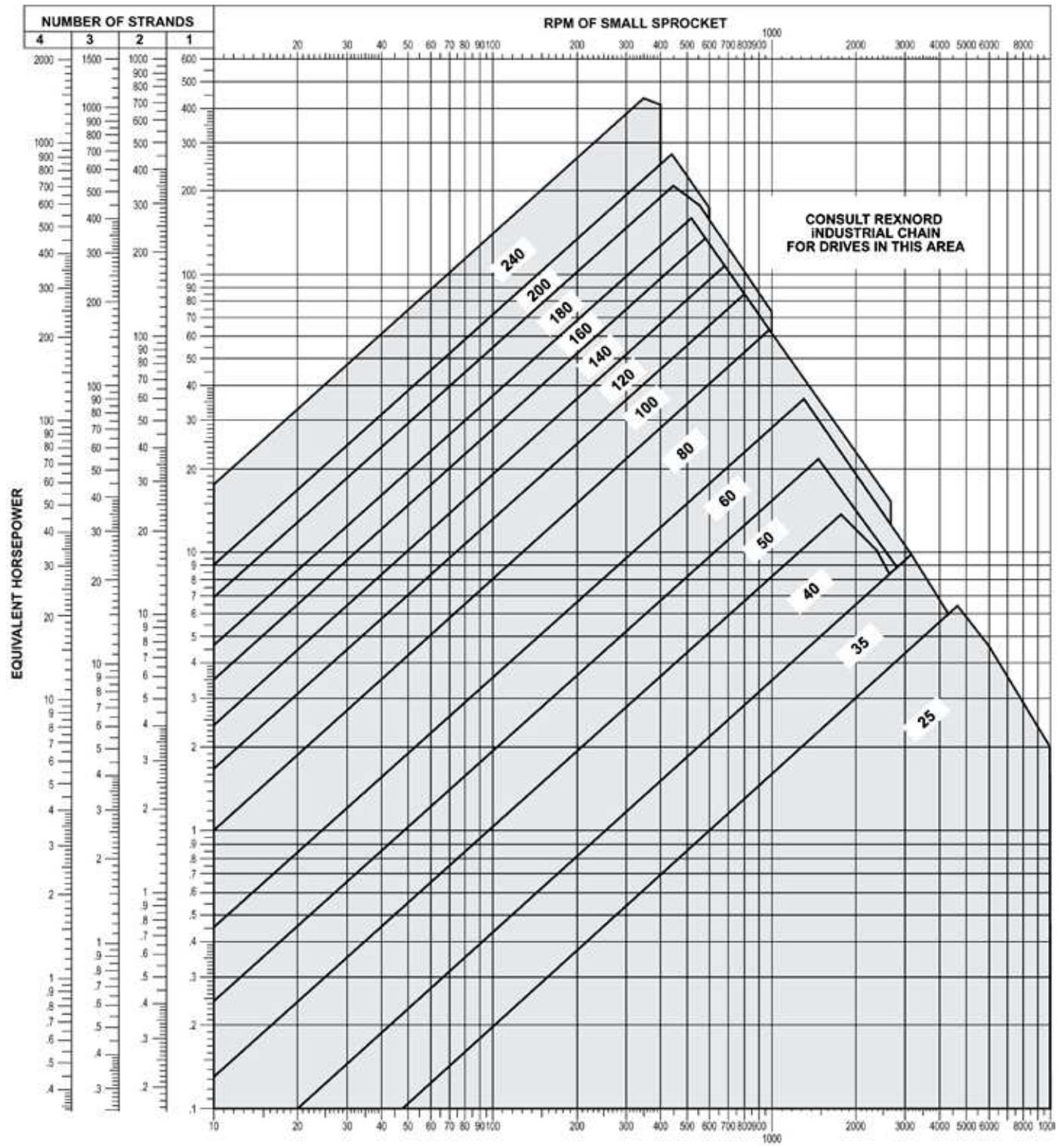

C

Chart D Trial selection of double-pitch roller chains

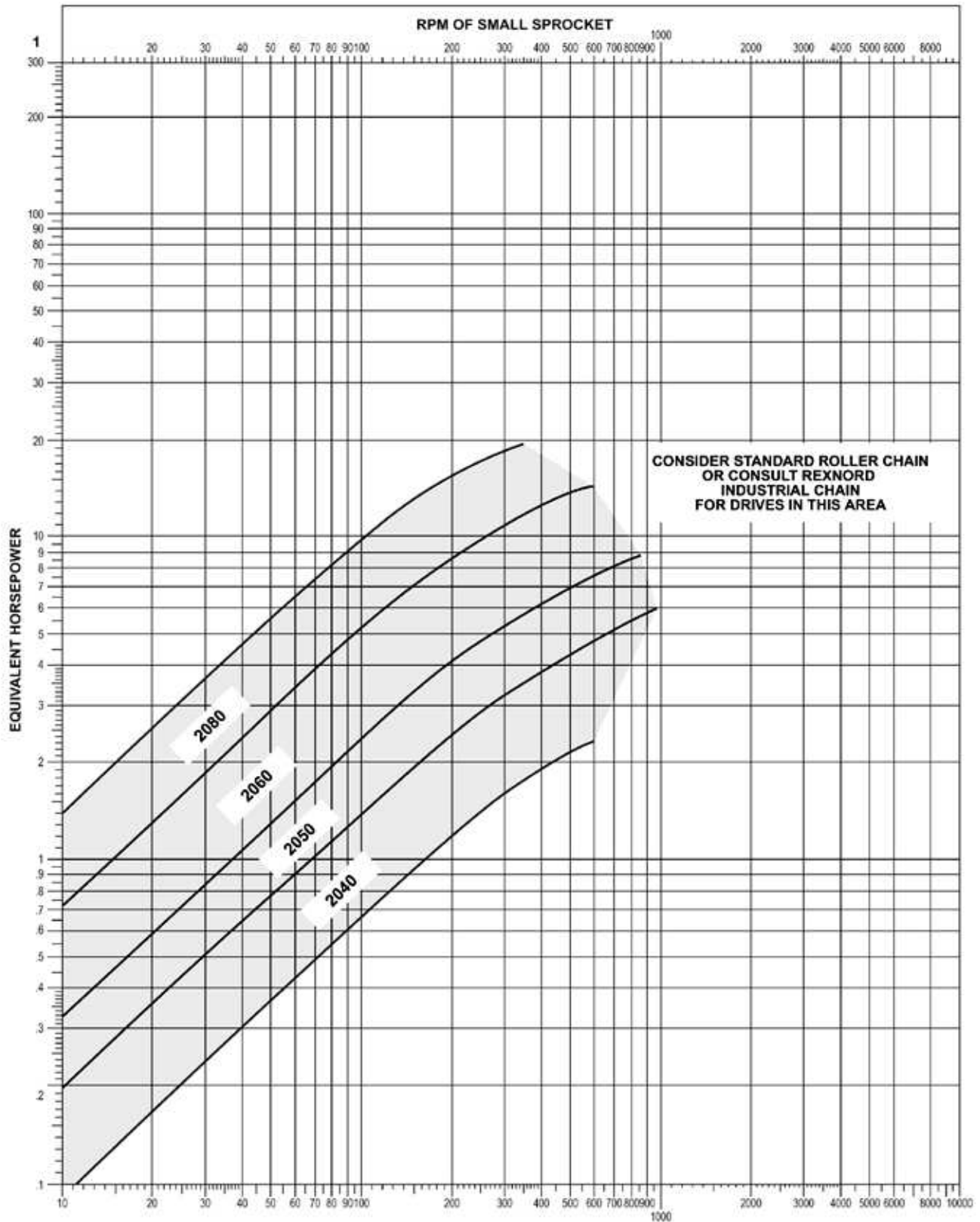

Drive Engineering

Table 1 Service factors

Driven equipment	Service factors			
	Input power			
	Internal combustion engine with hydraulic drive	Electric motor or turbine	Internal combustion engine with mechanical drive	
Agitators, liquid stock	1.0	1.0	1.2	
Beaters	1.2	1.3	1.4	
Blowers, centrifugal	1.0	1.0	1.2	
Boat propellers	1.4	1.5	1.7	
Compressors				
centrifugal	1.2	1.3	1.4	
reciprocating, 3 or more cylinders	1.2	1.3	1.4	
reciprocating, singular, 2 cylinders	1.4	1.5	1.7	
Conveyors				
uniformly loaded or fed	1.0	1.0	1.2	
not uniformly loaded or fed	1.2	1.3	1.4	
reciprocating	1.4	1.5	1.7	
Cookers, cereal	1.0	1.0	1.2	
Crushers	1.4	1.5	1.7	
Elevators, bucket				
uniformly loaded or fed	1.0	1.0	1.2	
not uniformly loaded or fed	1.2	1.3	1.4	
Fans, centrifugal	1.0	1.0	1.2	
Feeders				
rotary table	1.0	1.0	1.2	
apron, belt, screw, rotary vane	1.2	1.3	1.4	
reciprocating	1.4	1.5	1.7	
Generators	1.0	1.0	1.2	
Grinders	1.2	1.3	1.4	
Hoists	1.2	1.3	1.4	
Kettles, brew	1.0	1.0	1.2	
Kilns and dryers, rotary	1.2	1.3	1.4	
Lineshafts				
light or normal service	1.0	1.0	1.2	
heavy service	1.2	1.3	1.4	
Machinery				
uniform load, nonreversing	1.0	1.0	1.2	
moderate pulsating load, nonreversing	1.2	1.3	1.4	
severe impact or variable load, reversing	1.4	1.5	1.7	
Mills				
ball, pebble and tube	1.2	1.3	1.4	
hammer, rolling	1.4	1.5	1.7	
Pumps				
centrifugal	1.0	1.0	1.2	
reciprocating, 3 or more cylinders	1.2	1.3	1.4	
Screens, rotary, uniformly fed	1.2	1.3	1.4	
Basis for service factors:	Uniform load	1.0	1.0	1.2
	Moderate shock load	1.2	1.3	1.4
	Heavy shock load	1.4	1.5	1.7

Table 2 Multiple strand factors

Number of strands	Multiple strand factor
2	1.7
3	2.5
4	3.3
5	4.1
6	5.0
7 or more	Consult Rexnord

Table 3 Material or design variation factors

Type of chain	Variation factor	Speed limitations
Trans-Flex®	1.00	-
Stainless steel	4.00*	Limit to slower operating speeds.

* Assuming good lubrication; otherwise, make a conservative selection by using a larger factor, or consult Rexnord.

Chain length and center distance computations

A center distance equal to the diameter of the large sprocket plus one-half the diameter of the small sprocket is the suggested minimum for average applications.

An even number of pitches is desirable. However, if an odd number of pitches is required, offset links are provided.

These symbols are used for the following formulas:

- e = desired sprocket centers in inches
- E = exact sprocket centers in inches
- g = pitch diameter of small sprocket in inches

G = pitch diameter of large sprocket in inches

- N = actual length of chain in pitches
- P = chain pitch in inches
- t = number of teeth in small sprocket
- T = number of teeth in large sprocket

To determine the sprocket centers and chain length of a given drive, calculate factor A using the formula:

$$A = \frac{G-g}{2e}$$

Refer to Table 4 and select factors B, C and D corresponding to value A or the next higher value.

The number of pitches in the chain equals the sum of the pitches between sprockets and the pitches around the sprockets, or

$$\text{Number of pitches} = \frac{B e}{P} + C t + D T$$

The chain length should equal an even number of pitches so that the chain will couple without the use of an offset link. Therefore, select an even whole number nearest to the calculated number of pitches. Using this value as N, the exact sprocket centers is found by the following formula:

$$E = \frac{(N - C t - D T) P}{B}$$

Table 4 Factors for sprocket centers and chain length

A	B	C	D	A	B	C	D	A	B	C	D	A	B	C	D
.00000	2.0000	.5000	.5000	.19937	1.9598	.4361	.5639	.39073	1.8410	.3722	.6278	.56641	1.6483	.3083	.6917
.00436	2.0000	.4986	.5014	.20364	1.9581	.4347	.5653	.39474	1.8376	.3708	.6292	.57000	1.6433	.3069	.6931
.00873	1.9999	.4972	.5028	.20791	1.9563	.4333	.5667	.39875	1.8341	.3694	.6306	.57358	1.6383	.3056	.6944
.01309	1.9998	.4958	.5042	.21218	1.9545	.4319	.5681	.40275	1.8306	.3681	.6319	.57715	1.6333	.3042	.6958
.01745	1.9997	.4944	.5056	.21644	1.9526	.4306	.5694	.40674	1.8271	.3667	.6333	.58070	1.6282	.3028	.6972
.02181	1.9995	.4931	.5069	.22070	1.9507	.4292	.5708	.41072	1.8235	.3653	.6347	.58425	1.6231	.3014	.6986
.02618	1.9993	.4917	.5083	.22495	1.9487	.4278	.5722	.41469	1.8199	.3639	.6361	.58779	1.6180	.3000	.7000
.03054	1.9991	.4903	.5097	.22920	1.9468	.4264	.5736	.41866	1.8163	.3625	.6375	.59131	1.6129	.2986	.7014
.03490	1.9988	.4889	.5111	.23345	1.9447	.4250	.5750	.42262	1.8126	.3611	.6389	.59482	1.6077	.2972	.7028
.03926	1.9985	.4875	.5125	.23769	1.9427	.4236	.5764	.42657	1.8089	.3597	.6403	.59832	1.6025	.2958	.7042
.04362	1.9981	.4861	.5139	.24192	1.9406	.4222	.5778	.43051	1.8052	.3583	.6417	.60182	1.5973	.2944	.7056
.04798	1.9977	.4847	.5153	.24615	1.9385	.4208	.5792	.43445	1.8014	.3569	.6431	.60529	1.5920	.22931	.7069
.05234	1.9973	.4833	.5167	.25038	1.9363	.4194	.5806	.43837	1.7976	.3556	.6444	.60876	1.5867	.2917	.7083
.05669	1.9968	.4819	.5181	.25460	1.9341	.4181	.5819	.44229	1.7937	.3542	.6458	.61222	1.5814	.2903	.7097
.06105	1.9963	.4806	.5194	.25882	1.9319	.4167	.5833	.44620	1.7899	.3528	.6472	.61566	1.5760	.2889	.7111
.06540	1.9957	.4792	.5208	.26303	1.9296	.4153	.5847	.45010	1.7860	.3514	.6486	.61909	1.5706	.2875	.7125
.06976	1.9951	.4778	.5222	.26724	1.9273	.4139	.5861	.45399	1.7820	.3500	.6500	.62251	1.5652	.2861	.7139
.07411	1.9945	.4764	.5236	.27144	1.9249	.4125	.5875	.45787	1.7780	.3486	.6514	.62592	1.5598	.2847	.7153
.07846	1.9938	.4750	.5250	.27564	1.9225	.4111	.5889	.46175	1.7740	.3472	.6528	.62932	1.5543	.2833	.7167
.08281	1.9931	.4736	.5264	.27983	1.9201	.4097	.5903	.46561	1.7700	.3458	.6542	.63271	1.5488	.2819	.7181
.08716	1.9924	.4722	.5278	.28402	1.9176	.4083	.5917	.46947	1.7659	.3444	.6556	.63608	1.5432	.2806	.7194
.09150	1.9916	.4708	.5292	.28820	1.9151	.4069	.5875	.47332	1.7618	.3431	.6569	.63944	1.5377	.2792	.7208
.09585	1.9908	.4694	.5306	.29237	1.9126	.4056	.5944	.47716	1.7576	.3417	.6583	.64279	1.5321	.2778	.7222
.10019	1.9899	.4681	.5319	.29654	1.9100	.4042	.5958	.48099	1.7535	.3403	.6597	.64612	1.5265	.2764	.7236
.10453	1.9890	.4667	.5333	.30071	1.9074	.4028	.5972	.48481	1.7492	.3389	.6611	.64945	1.5208	.2750	.7250
.10887	1.9881	.4653	.5347	.30486	1.9048	.4014	.5986	.48862	1.7450	.3375	.6625	.65276	1.5151	.2736	.7264
.11320	1.9871	.4639	.5361	.30902	1.9021	.4000	.6000	.49242	1.7407	.3361	.6639	.65606	1.5094	.2722	.7278
.11754	1.9861	.4625	.5375	.31316	1.8994	.3986	.6014	.49622	1.7364	.3347	.6653	.65935	1.5037	.2708	.7292
.12187	1.9851	.4611	.5389	.31730	1.8966	.3972	.6028	.50000	1.7321	.333	.6667	.66262	1.4979	.2694	.7306
.12620	1.9840	.4597	.5403	.32144	1.8939	.3958	.6042	.50377	1.7277	.3319	.6681	.66588	1.4921	.2681	.7319
.13053	1.9829	.4583	.5417	.32557	1.8910	.3944	.6056	.50754	1.7233	.3306	.6694	.66913	1.4863	.2667	.7333
.13485	1.9817	.4569	.5431	.32969	1.8882	.3931	.6069	.51129	1.7188	.3292	.6708	.67237	1.4804	.2653	.7347
.13917	1.9805	.4556	.5444	.33381	1.8853	.3917	.6083	.51504	1.7143	.3278	.6722	.67559	1.4746	.2639	.7361
.14349	1.9793	.4542	.5458	.33792	1.8824	.3903	.6097	.51877	1.7098	.3264	.6736	.67880	1.4686	.2625	.7375
.14781	1.9780	.4528	.5472	.34202	1.8794	.3889	.6111	.52250	1.7053	.3250	.6750	.68200	1.4627	.2611	.7389
.15212	1.9767	.4514	.5486	.34612	1.8764	.3875	.6125	.52621	1.7007	.3236	.6764	.68518	1.4567	.2597	.7403
.15643	1.9754	.4500	.5500	.35021	1.8733	.3861	.6139	.52992	1.6961	.3222	.6778	.68835	1.4507	.2583	.7417
.16074	1.9740	.4486	.5514	.35429	1.8703	.3847	.6153	.53361	1.6915	.3208	.6792	.69151	1.4447	.2569	.7431
.16505	1.9726	.4472	.5528	.35837	1.8672	.3833	.6167	.53730	1.6868	.3194	.6806	.69466	1.4387	.2555	.7444
.16935	1.9711	.4458	.5542	.36244	1.8640	.3819	.6181	.54097	1.6821	.3181	.6819	.69779	1.4326	.2542	.7458
.17365	1.9696	.4444	.5556	.36650	1.8608	.3806	.6194	.54464	1.6773	.3167	.6833	.70091	1.4265	.2528	.7472
.17794	1.9681	.4431	.5569	.37056	1.8576	.3792	.6208	.54829	1.6726	.3153	.6847	.70401	1.4204	.2514	.7486
.18224	1.9665	.4417	.5583	.37461	1.8544	.3778	.6222	.55194	1.6678	.3139	.6861	.70711	1.4142	.2500	.7500
.18652	1.9649	.4403	.5597	.37865	1.8511	.3764	.6236	.55557	1.6629	.3125	.6875				
.19081	1.9633	.4389	.5611	.38268	1.8478	.3750	.6250	.55919	1.6581	.3111	.6889				
.19509	1.9616	.4375	.5625	.38671	1.8444	.3736	.6264	.56280	1.6532	.3097	.6903				

Drive Engineering

No. 25 chain .250" pitch

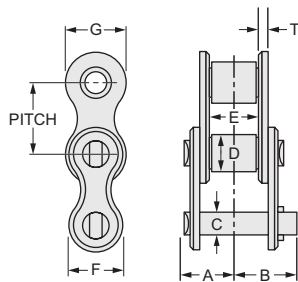

Fig. 6453

Specifications and dimensions

Chain Number	Average Ultimate strength, pounds	Joint bearing area sq. in.	Weight per foot, pounds	Dimensions, inches							
				A	B	C	D	E	F	G	T
25	940	.017	.08	.15	.19	.090	.130 Δ	.13	.20	.23	.03

Available only in riveted construction. All other sizes may be furnished cottered or riveted.
 Δ Bushing Diameter. Chain is rollerless.

Ratings

Number of teeth, in small sprocket	Maximum bore inches	Horsepower for single strand chain ▲																			
		RPM of small sprocket																			
		100	500	900	1200	1800	2500	3000	3500	4000	4500	5000	5500	6000	6500	7000	7500	8000	8500	9000	10000
11	.313	0.05	0.23	0.39	0.50	0.73	0.98	1.15	1.32	1.38	1.16	0.99	0.86	0.75	0.67	0.60	0.54	0.49	0.41	0.35	
12	.375	0.06	0.25	0.43	0.55	0.80	1.07	1.26	1.45	1.57	1.32	1.12	0.97	0.86	0.76	0.68	0.61	0.56	0.51	0.47	0.40
13	.438	0.06	0.27	0.47	0.60	0.87	1.17	1.38	1.58	1.77	1.49	1.27	1.10	0.96	0.86	0.77	0.69	0.63	0.57	0.53	0.45
14	.563	0.07	0.30	0.50	0.65	0.94	1.27	1.49	1.71	1.93	1.66	1.42	1.23	1.08	0.96	0.86	0.77	0.70	0.64	0.59	0.50
15	.563	0.08	0.32	0.54	0.70	1.01	1.36	1.61	1.85	2.08	1.84	1.57	1.36	1.20	1.06	0.95	0.86	0.78	0.71	0.65	0.56
16	.563	0.08	0.34	0.58	0.76	1.09	1.46	1.72	1.98	2.23	2.03	1.73	1.50	1.32	1.17	1.05	0.94	0.86	0.78	0.72	0.61
17	.625	0.09	0.37	0.62	0.81	1.16	1.56	1.84	2.11	2.38	2.22	1.90	1.64	1.44	1.28	1.14	1.03	0.94	0.86	0.79	0.67
18	.750	0.09	0.39	0.66	0.86	1.24	1.66	1.96	2.25	2.53	2.42	2.07	1.79	1.57	1.39	1.25	1.12	1.02	0.93	0.86	0.73
19	.813	0.10	0.41	0.70	0.91	1.31	1.76	2.07	2.38	2.69	2.62	2.24	1.94	1.70	1.51	1.35	1.22	1.11	1.01	0.93	0.79
20	.875	0.10	0.44	0.74	0.96	1.38	1.86	2.19	2.52	2.84	2.83	2.42	2.10	1.84	1.63	1.46	1.32	1.20	1.09	1.00	0.86
21	.875	0.11	0.46	0.78	1.01	1.46	1.96	2.31	2.66	2.99	3.05	2.60	2.26	1.98	1.76	1.57	1.42	1.29	1.17	1.08	0.92
22	.938	0.11	0.48	0.82	1.07	1.53	2.06	2.43	2.79	3.15	3.27	2.79	2.42	2.12	1.88	1.69	1.52	1.38	1.26	1.16	0.99
23	1.000	0.12	0.51	0.86	1.12	1.61	2.16	2.55	2.93	3.30	3.50	2.98	2.59	2.27	2.01	1.80	1.62	1.47	1.35	1.24	1.06
24	1.063	0.13	0.53	0.90	1.17	1.69	2.27	2.67	3.07	3.46	3.73	3.18	2.76	2.42	2.15	1.92	1.73	1.57	1.44	1.32	1.12
25	1.188	0.13	0.56	0.94	1.22	1.76	2.37	2.79	3.21	3.61	3.96	3.38	2.93	2.57	2.28	2.04	1.84	1.67	1.53	1.40	1.20
28	1.250	0.15	0.63	1.07	1.38	1.99	2.68	3.15	3.62	4.09	4.54	4.01	3.47	3.05	2.70	2.42	2.18	1.98	1.81	1.66	1.42
30	1.313	0.16	0.68	1.15	1.49	2.15	2.88	3.40	3.90	4.40	4.89	4.45	3.85	3.38	3.00	2.68	2.42	2.20	2.01	1.84	1.57
32	1.500	0.17	0.73	1.23	1.60	2.30	3.09	3.64	4.18	4.72	5.25	4.90	4.25	3.73	3.30	2.96	2.67	2.42	2.21	2.03	1.73
35	1.688	0.19	0.80	1.36	1.76	2.53	3.41	4.01	4.61	5.20	5.78	5.60	4.86	4.26	3.78	3.38	3.05	2.77	2.53	2.32	1.98
40	1.875	0.22	0.92	1.57	2.03	2.93	3.93	4.64	5.32	6.00	6.68	6.85	5.93	5.21	4.62	4.13	3.73	3.38	3.09	2.83	2.42
Lubrication type ■		A				B						C									

▲ Ratings are based on a service factor of 1. For a complete list of service factors, refer to Table 1, page C-7.
 The ratings listed above apply directly to lubricated, single strand, standard roller chains.
 To select chains that vary in design or material from standard roller chain, use the factors in Table 3, page C-7.

- Type A: Manual or drip (Maximum chain speed 500 FPM)
- Type B: Bath or disc (Maximum chain speed 3500 FPM)
- Type C: Forced (pump)

No. 25 sprockets .250" pitch

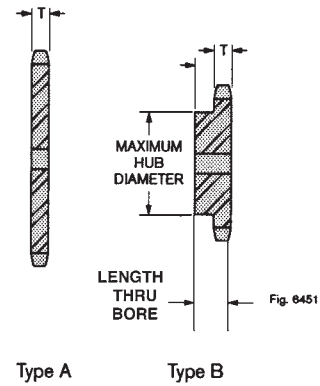
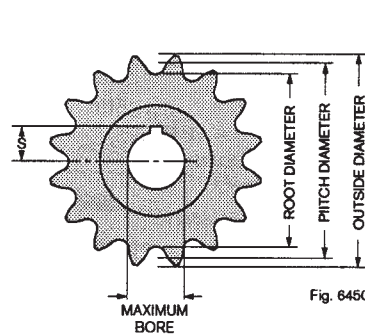

Dimensions

Number of teeth	Pitch diameter, inches	Root diameter, inches	Outside diameter, inches Δ	Maximum hub and groove diameter, inches	Maximum bore with standard keyseat, inches ▲	S max., inches	Number of teeth	Pitch diameter, inches	Root diameter, inches	Outside diameter, inches Δ	Number of teeth	Pitch diameter, inches	Root diameter, inches	Outside diameter, inches Δ
8	.653	.523	.754	.31	.250	.125	46	3.664	3.805	3.534	84	6.686	6.556	6.832
9	.731	.601	.837	.41	.250	.125	47	3.743	3.885	3.613	85	6.766	6.636	6.911
10	.809	.679	.919	.48	.250	.125	48	3.823	3.964	3.693	86	6.845	6.715	6.991
11	.887	.757	1.002	.56	.313	.156	49	3.902	4.044	3.772	87	6.925	6.795	7.070
12	.966	.836	1.083	.64	.375	.219	50	3.982	4.124	3.852	88	7.004	6.874	7.150
13	1.045	.915	1.167	.73	.438	.219	51	4.061	4.203	3.931	89	7.084	6.954	7.230
14	1.124	.994	1.246	.81	.563	.313	52	4.141	4.283	4.011	90	7.164	7.034	7.309
15	1.203	1.073	1.326	.89	.563	.328	53	4.220	4.363	4.090	91	7.243	7.113	7.389
16	1.282	1.152	1.407	.97	.563	.344	54	4.300	4.442	4.170	92	7.323	7.193	7.468
17	1.361	1.231	1.487	1.06	.625	.375	55	4.379	4.522	4.249	93	7.402	7.272	7.548
18	1.440	1.310	1.568	1.13	.750	.469	56	4.459	4.602	4.329	94	7.482	7.352	7.628
19	1.519	1.389	1.648	1.22	.813	.500	57	4.538	4.681	4.408	95	7.561	7.431	7.707
20	1.598	1.468	1.729	1.30	.875	.531	58	4.618	4.761	4.488	96	7.641	7.511	7.787
21	1.678	1.548	1.809	1.38	.875	.563	59	4.697	4.841	4.567	97	7.720	7.590	7.866
22	1.757	1.627	1.889	1.45	.938	.594	60	4.777	4.920	4.647	98	7.800	7.670	7.946
23	1.836	1.706	1.969	1.53	1.000	.625	61	4.857	4.727	5.000	99	7.880	7.750	8.026
24	1.915	1.785	2.049	1.61	1.063	.656	62	4.936	4.806	5.080	100	7.959	7.829	8.105
25	1.995	1.865	2.129	1.69	1.188	.719	63	5.016	4.886	5.159	101	8.039	7.882	8.185
26	2.074	1.944	2.209	1.77	1.250	.734	64	5.095	4.965	5.239	102	8.118	7.962	8.264
27	2.154	2.024	2.289	1.86	1.250	.750	65	5.175	5.045	5.319	103	8.198	8.042	8.344
28	2.233	2.103	2.389	1.94	1.250	.766	66	5.254	5.124	5.398	104	8.277	8.121	8.424
29	2.312	2.182	2.449	2.02	1.250	.781	67	5.334	5.204	5.478	105	8.357	8.201	8.503
30	2.392	2.262	2.529	2.09	1.313	.813	68	5.413	5.283	5.558	106	8.437	8.280	8.583
31	2.471	2.341	2.609	2.19	1.375	.844	69	5.493	5.363	5.637	107	8.516	8.360	8.662
32	2.551	2.421	2.688	2.25	1.500	.938	70	5.572	5.442	5.717	108	8.596	8.439	8.742
33	2.630	2.500	2.768	2.34	1.563	.969	71	5.652	5.522	5.796	109	8.675	8.519	8.822
34	2.710	2.580	2.848	2.41	1.625	1.000	72	5.732	5.602	5.876	110	8.755	8.599	8.901
35	2.789	2.659	2.928	2.48	1.688	1.031	73	5.811	5.681	5.956	111	8.834	8.678	8.981
36	2.869	2.739	3.008	2.58	1.750	1.063	74	5.891	5.761	6.035	112	8.914	8.758	9.060
37	2.948	2.818	3.087	2.66	1.750	1.094	75	5.970	5.840	6.115	113	8.994	8.837	9.140
38	3.028	2.898	3.167	2.73	1.813	1.156	76	6.050	5.920	6.195	114	9.073	8.917	9.220
39	3.107	2.977	3.247	2.81	1.813	1.172	77	6.129	5.999	6.274	115	9.153	8.996	9.299
40	3.187	3.057	3.327	2.89	1.875	1.188	78	6.209	6.079	6.354	116	9.232	9.076	9.379
41	3.266	3.136	3.406	2.97	1.938	1.219	79	6.288	6.158	6.433	117	9.312	9.156	9.458
42	3.346	3.216	3.486	3.05	2.000	1.250	80	6.368	6.238	6.513	118	9.391	9.235	9.538
43	3.425	3.295	3.566	3.13	2.125	1.313	81	6.448	6.318	6.593	119	9.471	9.315	9.618
44	3.505	3.375	3.646	3.20	2.188	1.344	82	6.527	6.397	6.672	120	9.550	9.394	9.697
45	3.584	3.454	3.725	3.30	2.250	1.375	83	6.607	6.477	6.752	Larger sizes available			

Hub length thru bore

Sprocket type	Number of teeth	Length thru bore, inches
B	8 to 19	.50
	20 to 35	.63
	36 to 73	.75
	74 to 100	.88

Tooth dimensions

T = .110" + .000", -.007"

Recommended standard bore tolerances, keyseat dimensions, eccentricity tolerances, and similar data, page G-2.

Δ Non-functional dimension that may vary with the type of cutter used.

▲ Based on maximum hub diameter.

Drive Engineering

No. 35 chain .375" pitch

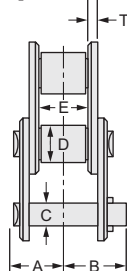
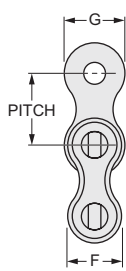

Fig. 6453

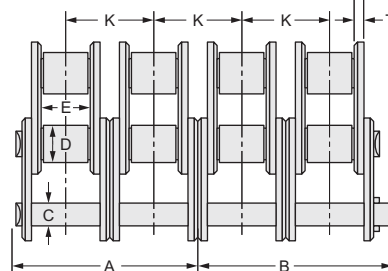

Fig. 6447

Specifications and dimensions

Chain Number	Chain width, number of strands	Average Ultimate strength, pounds	Joint bearing area sq. in.	Weight per foot, pounds	Dimensions, inches								
					A	B	C	D	E	F	G	K	T
35	Single	2,100	.041	.22	.24	.31	.141	.200 Δ	.19	.31	.35	.399	.05
35-2	Double	4,200	.082	.42	.45	.50	.141	.200 Δ	.19	.31	.35	.399	.05
35-3	Triple	6,450	.123	.62	.63	.70	.141	.200 Δ	.19	.31	.35	.399	.05
35-4	Quadruple	8,600	.164	.82	.78	.91	.141	.200 Δ	.19	.31	.35	.399	.05
35-5	Quintuple	10,750	.205	1.06	1.03	1.11	.141	.200 Δ	.19	.31	.35	.399	.05
35-6	Sextuple	12,900	.246	1.27	1.23	1.31	.141	.200 Δ	.19	.31	.35	.399	.05

Available only in riveted construction.
 Δ Bushing Diameter. Chain is rollerless.

Ratings

Number of teeth, in small sprocket	Maximum bore inches	Horsepower for single strand chain \blacktriangle																				
		RPM of small sprocket																				
		100	500	900	1200	1800	2500	3000	3500	4000	4500	5000	5500	6000	6500	7000	7500	8000	8500	9000	10000	
11	.563	0.18	0.77	1.31	1.70	2.45	3.30	2.94	2.33	1.91	1.60	1.37	1.18	1.04	0.92	0.82	0.74	0.67	0.62	0.57	0.48	
12	.625	0.20	0.85	1.44	1.87	2.70	3.62	3.35	2.66	2.17	1.82	1.56	1.35	1.18	1.05	0.94	0.85	0.77	0.70	0.64	0.55	
13	.688	0.22	0.93	1.57	2.04	2.94	3.95	3.77	3.00	2.45	2.05	1.75	1.52	1.33	1.18	1.06	0.95	0.87	0.79	0.73	0.62	
14	.813	0.24	1.01	1.71	2.21	3.18	4.28	4.22	3.35	2.74	2.30	1.96	1.70	1.49	1.32	1.18	1.07	0.97	0.88	0.81	0.69	
15	.875	0.25	1.08	1.84	2.38	3.43	4.61	4.68	3.71	3.04	2.55	2.17	1.88	1.65	1.47	1.31	1.18	1.07	0.98	0.90	0.77	
16	.938	0.27	1.16	1.97	2.55	3.68	4.94	5.15	4.09	3.35	2.81	2.40	2.08	1.82	1.62	1.45	1.30	1.18	1.08	0.99	0.85	
17	1.063	0.29	1.24	2.10	2.73	3.93	5.28	5.64	4.48	3.67	3.07	2.62	2.27	2.00	1.77	1.58	1.43	1.30	1.18	1.09	0.93	
18	1.188	0.31	1.32	2.24	2.90	4.18	5.61	6.15	4.88	3.99	3.35	2.86	2.48	2.17	1.93	1.73	1.56	1.41	1.29	1.18	1.01	
19	1.250	0.33	1.40	2.37	3.07	4.43	5.95	6.67	5.29	4.33	3.63	3.10	2.69	2.36	2.09	1.87	1.69	1.53	1.40	1.28	1.10	
20	1.313	0.35	1.48	2.51	3.25	4.68	6.29	7.20	5.72	4.68	3.92	3.35	2.90	2.55	2.26	2.02	1.82	1.65	1.51	1.39	1.18	
21	1.438	0.37	1.56	2.64	3.42	4.93	6.63	7.75	6.15	5.03	4.22	3.60	3.12	2.74	2.43	2.17	1.96	1.78	1.62	1.49	1.27	
22	1.563	0.38	1.64	2.78	3.60	5.19	6.97	8.21	6.59	5.40	4.52	3.86	3.35	2.94	2.61	2.33	2.10	1.91	1.74	1.60	1.37	
23	1.688	0.40	1.72	2.92	3.78	5.44	7.31	8.62	7.05	5.77	4.83	4.13	3.58	3.14	2.79	2.49	2.25	2.04	1.86	1.71	1.46	
24	1.750	0.42	1.80	3.05	3.96	5.70	7.66	9.02	7.51	6.15	5.15	4.40	3.81	3.35	2.97	2.66	2.40	2.17	1.99	1.82	1.56	
25	1.813	0.44	1.88	3.19	4.13	5.95	8.00	9.43	7.99	6.54	5.48	4.68	4.05	3.56	3.16	2.82	2.55	2.31	2.11	1.94	1.65	
28	2.125	0.50	2.12	3.61	4.67	6.73	9.05	10.7	9.47	7.75	6.49	5.55	4.81	4.22	3.74	3.35	3.02	2.74	2.50	2.30	1.96	
30	2.281	0.54	2.29	3.89	5.03	7.25	9.74	11.5	10.5	8.59	7.20	6.15	5.33	4.68	4.15	3.71	3.35	3.04	2.77	2.55	2.17	
32	2.500	0.58	2.45	4.17	5.40	7.77	10.4	12.3	11.6	9.47	7.93	6.77	5.87	5.15	4.57	4.09	3.69	3.35	3.06	2.81	0	
35	2.781	0.64	2.70	4.59	5.95	8.56	11.5	13.6	13.2	10.8	9.08	7.75	6.72	5.90	5.23	4.68	4.22	3.83	3.50	3.21	0	
40	3.250	0.73	3.12	5.30	6.87	9.89	13.3	15.7	16.2	13.2	11.1	9.47	8.21	7.20	6.39	5.72	5.15	4.68	0	-	-	
Lubrication type \blacksquare		A	B					C														

\blacktriangle Ratings are based on a service factor of 1. For a complete list of service factors, refer to Table 1, page C-7. The ratings listed above apply directly to lubricated, single strand, standard roller chains. For multiple strand chains, apply the factors shown in the table at right. To select chains that vary in design or material from standard roller chain, use the factors in Table 3, page C-7.

- \blacksquare Type A: Manual or drip (Maximum chain speed 370 FPM)
- Type B: Bath or disc (Maximum chain speed 2800 FPM)
- Type C: Forced (pump)

Multiple strand factors

Number of strands	Multiple strand factor
2	1.7
3	2.5
4	3.3
5	4.1
6	5.0
7 or more	Consult Rexnord

No. 35 sprockets .375" pitch

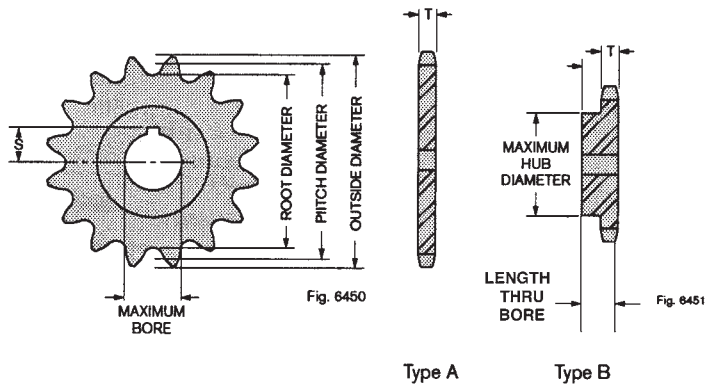

Dimensions

Number of teeth	Pitch diameter, inches	Root diameter, inches	Outside diameter, inches Δ	Maximum hub and groove diameter, inches	Maximum bore with standard keyseat, inches \blacktriangle	S max., inches	Number of teeth	Pitch diameter, inches	Root diameter, inches	Outside diameter, inches Δ	Number of teeth	Pitch diameter, inches	Root diameter, inches	Outside diameter, inches Δ
8	.980	.780	1.130	.50	.250	.125	46	5.495	5.295	5.708	84	10.029	9.829	10.247
9	1.096	.896	1.255	.63	.375	.250	47	5.614	5.414	5.827	85	10.148	9.948	10.367
10	1.214	1.014	1.379	.75	.500	.313	48	5.734	5.534	5.946	86	10.268	10.066	10.486
11	1.331	1.131	1.502	.86	.563	.344	49	5.853	5.653	6.066	87	10.387	10.187	10.606
12	1.449	1.249	1.625	.98	.625	.406	50	5.972	5.772	6.186	88	10.506	10.306	10.725
13	1.567	1.367	1.746	1.11	.688	.438	51	6.091	5.891	6.305	89	10.626	10.426	10.844
14	1.685	1.485	1.868	1.23	.813	.500	52	6.211	6.011	6.425	90	10.745	10.545	10.964
15	1.804	1.604	1.989	1.36	.875	.531	53	6.330	6.130	6.544	91	10.864	10.664	11.083
16	1.922	1.722	2.110	1.47	.938	.594	54	6.449	6.249	6.664	92	10.984	10.784	11.203
17	2.041	1.841	2.231	1.59	1.063	.656	55	6.569	6.369	6.783	93	11.103	10.903	11.322
18	2.159	1.959	2.352	1.72	1.188	.719	56	6.688	6.488	6.903	94	11.222	11.022	11.441
19	2.278	2.078	2.472	1.84	1.250	.750	57	6.807	6.607	7.022	95	11.342	11.142	11.561
20	2.397	2.197	2.593	1.95	1.313	.813	58	6.927	6.727	7.142	96	11.461	11.261	11.680
21	2.516	2.316	2.713	2.08	1.438	.906	59	7.046	6.846	7.261	97	11.580	11.380	11.800
22	2.635	2.435	2.833	2.20	1.563	.969	60	7.165	6.965	7.381	98	11.700	11.500	11.919
23	2.754	2.554	2.953	2.31	1.688	1.031	61	7.284	7.084	7.500	99	11.819	11.619	12.038
24	2.873	2.673	3.074	2.44	1.750	1.094	62	7.404	7.204	7.619	100	11.938	11.738	12.158
25	2.992	2.792	3.194	2.56	1.813	1.156	63	7.523	7.323	7.739	101	12.058	11.858	12.277
26	3.111	2.911	3.314	2.67	1.938	1.219	64	7.642	7.442	7.858	102	12.177	11.977	12.397
27	3.230	3.030	3.434	2.80	2.000	1.250	65	7.762	7.562	7.978	103	12.297	12.097	12.519
28	3.349	3.149	3.553	2.92	2.125	1.313	66	7.881	7.681	8.097	104	12.416	12.216	12.635
29	3.468	3.268	3.673	3.03	2.250	1.375	67	8.000	7.800	8.217	105	12.535	12.335	12.755
30	3.588	3.388	3.793	3.16	2.281	1.438	68	8.120	7.920	8.336	106	12.655	12.455	12.874
31	3.707	3.507	3.913	3.28	2.375	1.500	69	8.239	8.039	8.456	107	12.774	12.574	12.994
32	3.826	3.626	4.032	3.39	2.500	1.563	70	8.358	8.158	8.575	108	12.893	12.693	13.113
33	3.945	3.745	4.152	3.52	2.625	1.625	71	8.478	8.278	8.695	109	13.013	12.813	13.232
34	4.064	3.864	4.272	3.64	2.750	1.688	72	8.597	8.397	8.814	110	13.132	12.932	13.352
35	4.183	3.983	4.392	3.75	2.781	1.750	73	8.716	8.516	8.934	111	13.251	13.051	13.471
36	4.303	4.103	4.511	3.88	2.875	1.813	74	8.836	8.636	9.053	112	13.371	13.171	13.590
37	4.422	4.222	4.631	4.00	3.000	1.875	75	8.955	8.755	9.172	113	13.490	13.290	13.710
38	4.541	4.341	4.751	4.11	3.125	1.938	76	9.074	8.874	9.291	114	13.609	13.409	13.829
39	4.660	4.460	4.870	4.23	3.188	1.969	77	9.194	8.994	9.411	115	13.729	13.529	13.949
40	4.780	4.580	4.990	4.36	3.250	2.000	78	9.313	9.113	9.531	116	13.848	13.648	14.068
41	4.899	4.699	5.109	4.47	3.281	2.063	79	9.432	9.232	9.650	117	13.969	13.768	14.187
42	5.018	4.818	5.229	4.59	3.375	2.125	80	9.552	9.352	9.770	118	14.087	13.887	14.307
43	5.137	4.937	5.349	4.72	3.438	2.156	81	9.671	9.471	9.889	119	14.206	14.006	14.426
44	5.257	5.057	5.468	4.83	3.500	2.188	82	9.790	9.590	10.008	120	14.326	14.126	14.546
45	5.376	5.176	5.588	4.95	3.625	2.250	83	9.910	9.710	10.128	Larger sizes available			

Hub length thru bore, inches

Sprocket Type	Number of Teeth	Chain Width, Number of Strands					
		1	2	3	4	5	6
B	8 to 19	.75	1.25	1.75	2.13	2.63	3.13
	20 to 44	.88	1.38	1.88	2.25	2.75	3.25
	45 to 102	1.00	1.50	2.00	2.38	2.88	3.38
	103 to 120	1.25	1.75	2.25	2.63	3.13	3.63
C	41 to 80	1.75	2.00	2.25	2.50	2.75	3.00
	81 to 120	2.00	2.25	2.50	2.75	3.00	3.25

Tooth dimensions, inches

Dimension	Chain Width, Number of Strands					
	1	2	3	4	5	6
T	.168	.162	.162	.149	.149	.149
L	-	.560	.958	1.343	1.741	2.139
K	-	.399	.399	.399	.399	.399
Machined sprockets +.000", -.008"						
Tolerances for T and L						
Hot rolled steel plate sprockets or unfinished forgings +.000", -.027"						

Recommended standard bore tolerances, keyseat dimensions, eccentricity tolerances and similar data, page G-2.

Δ Non-functional dimension that may vary with the type of cutter used.

\blacktriangle Based on maximum hub diameter.

Drive engineering

No. 40 chain .500" pitch

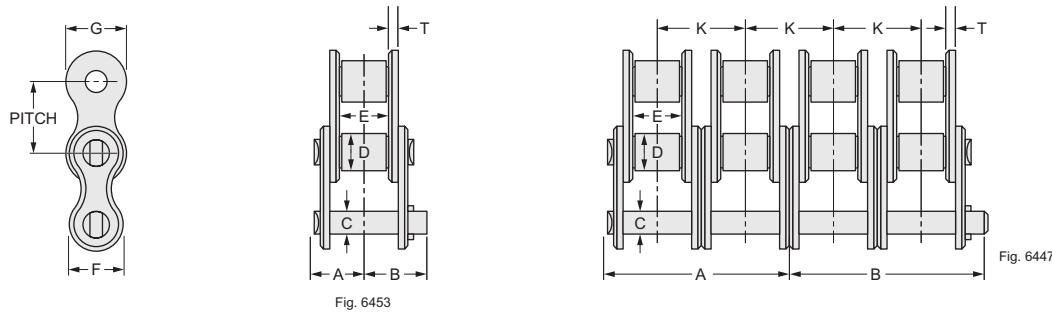

Specifications and dimensions

Chain Number	Chain Width, Number of Strands	Average ultimate strength, pounds	Joint bearing area, sq. in.	Weight per foot, pounds	Dimensions, inches								
					A	B	C	D	E	F	G	K	T
40	Single	3,700	.068	.39	.32	.38	.156	.313	.31	.41	.47	.566	.06
40-2	Double	7,400	.136	.79	.60	.67	.156	.313	.31	.41	.47	.566	.06
40-3	Triple	11,100	.204	1.18	.89	.95	.156	.313	.31	.41	.47	.566	.06
40-4	Quadruple	14,800	.272	1.57	1.17	1.23	.156	.313	.31	.41	.47	.566	.06
40-5	Quintuple	18,500	.340	1.97	1.45	1.52	.156	.313	.31	.41	.47	.566	.06
40-6	Sextuple	22,200	.408	2.36	1.73	1.80	.156	.313	.31	.41	.47	.566	.06

Available only in riveted construction.

Ratings

Number of teeth, in small sprocket	Maximum bore inches	Horsepower for single strand chain ▲																			
		RPM of small sprocket																			
		50	100	200	300	400	500	700	1000	1200	1400	1600	1800	2400	3000	3500	4000	5000	6000	7000	8000
11	.750	0.23	0.43	0.80	1.16	1.50	1.83	2.48	3.42	4.03	4.63	5.22	4.66	3.03	2.17	1.72	1.41	1.01	0.77	0.61	0.50
12	.844	0.25	0.47	0.88	1.27	1.65	2.01	2.73	3.76	4.43	5.09	5.74	5.31	3.45	2.47	1.96	1.60	1.15	0.87	0.69	0.57
13	1.000	0.28	0.52	0.96	1.39	1.80	2.20	2.97	4.10	4.83	5.55	6.26	5.99	3.89	2.79	2.21	1.81	1.29	0.98	0.78	0.64
14	1.188	0.30	0.56	1.04	1.50	1.95	2.38	3.22	4.44	5.23	6.01	6.78	6.70	4.35	3.11	2.47	2.02	1.45	1.10	0.87	0.71
15	1.250	0.32	0.60	1.12	1.62	2.10	2.56	3.47	4.78	5.64	6.47	7.30	7.43	4.82	3.45	2.74	2.24	1.60	1.22	0.97	0.79
16	1.375	0.35	0.65	1.20	1.74	2.25	2.75	3.72	5.13	6.04	6.94	7.83	8.18	5.31	3.80	3.02	2.47	1.77	1.34	1.07	0.87
17	1.500	0.37	0.69	1.29	1.85	2.40	2.93	3.97	5.48	6.45	7.41	8.36	8.96	5.82	4.17	3.31	2.71	1.94	1.47	1.17	0.96
18	1.625	0.39	0.73	1.37	1.97	2.55	3.12	4.22	5.82	6.86	7.88	8.89	9.76	6.34	4.54	3.60	2.95	2.11	1.60	1.27	0
19	1.750	0.42	0.78	1.45	2.09	2.71	3.31	4.48	6.17	7.27	8.36	9.42	10.5	6.88	4.92	3.91	3.20	2.29	1.74	1.38	0
20	1.875	0.44	0.82	1.53	2.21	2.86	3.50	4.73	6.53	7.69	8.83	9.96	11.1	7.43	5.31	4.22	3.45	2.47	1.88	1.49	0
21	2.063	0.46	0.87	1.62	2.33	3.02	3.69	4.99	6.88	8.11	9.31	10.5	11.7	7.99	5.72	4.54	3.71	2.66	2.02	1.60	0
22	2.188	0.49	0.91	1.70	2.45	3.17	3.88	5.25	7.23	8.52	9.79	11.0	12.3	8.57	6.13	4.87	3.98	2.85	2.17	1.72	0
23	2.250	0.51	0.96	1.78	2.57	3.33	4.07	5.51	7.59	8.94	10.3	11.6	12.9	9.16	6.55	5.20	4.26	3.05	2.32	1.84	0
24	2.250	0.54	1.00	1.87	2.69	3.48	4.26	5.76	7.95	9.36	10.8	12.1	13.5	9.76	6.99	5.54	4.54	3.25	2.47	1.96	0
25	2.281	0.56	1.05	1.95	2.81	3.64	4.45	6.02	8.30	9.78	11.2	12.7	14.1	10.4	7.43	5.89	4.82	3.45	2.63	0	-
28	2.625	0.63	1.18	2.20	3.18	4.11	5.03	6.81	9.39	11.1	12.7	14.3	15.9	12.3	8.80	6.99	5.72	4.09	3.11	0	-
30	2.750	0.68	1.27	2.38	3.42	4.43	5.42	7.33	10.1	11.9	13.7	15.4	17.2	13.6	9.76	7.75	6.34	4.54	3.45	0	-
32	3.000	0.73	1.36	2.55	3.67	4.75	5.81	7.86	10.8	12.8	14.7	16.5	18.4	15.0	10.8	8.54	6.99	5.00	0	-	-
35	3.563	0.81	1.50	2.81	4.04	5.24	6.40	8.66	11.9	14.1	16.2	18.2	20.3	17.2	12.3	9.76	7.99	5.72	0	-	-
40	3.781	0.93	1.74	3.24	4.67	6.05	7.39	10.0	13.8	16.3	18.7	21.1	23.4	21.0	15.0	11.9	9.76	6.99	0	-	-
Lubrication type ■	A	B						C													

▲ Ratings are based on a service factor of 1. For a complete list of service factors, refer to Table 1, page C-7.

The ratings listed above apply directly to lubricated, single strand, standard roller chains.

For multiple strand chains, apply the factors shown in the table at right. To select chains that vary in design or material from standard roller chain, use the factors in Table 3, page C-7.

- Type A: Manual or drip (Maximum chain speed 300 FPM)
- Type B: Bath or disc (Maximum chain speed 2300 FPM)
- Type C: Forced (pump)

Number of strands	Multiple strand factor
2	1.7
3	2.5
4	3.3
5	4.1
6	5.0
7 or more	Consult Rexnord

No. 40 sprockets .500" pitch

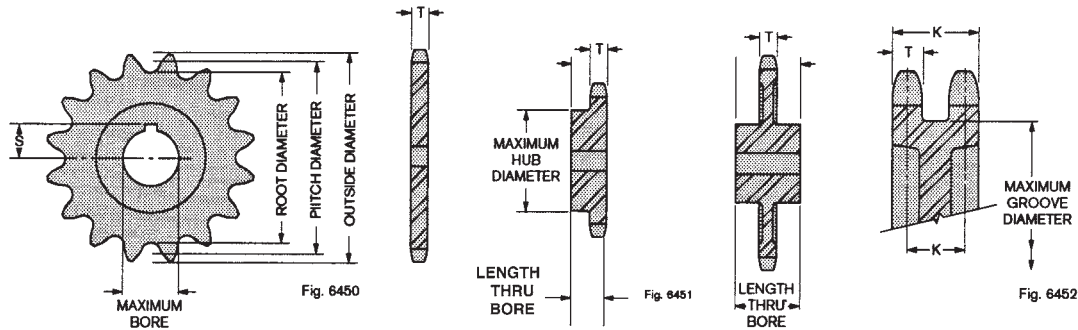

Dimensions

Number of teeth	Pitch diameter, inches	Root diameter, inches	Outside diameter, inches Δ	Maximum hub and groove diameter, inches	Maximum bore with standard keyseat, inches ▲	S max., inches	Number of teeth	Pitch diameter, inches	Root diameter, inches	Outside diameter, inches Δ	Number of teeth	Pitch diameter, inches	Root diameter, inches	Outside diameter, inches Δ
8	1.307	.995	1.507	.67	.375	.188	46	7.327	7.015	7.609	84	13.372	13.060	13.663
9	1.462	1.150	1.674	.84	.500	.313	47	7.486	7.174	7.769	85	13.531	13.219	13.822
10	1.618	1.306	1.839	1.00	.625	.406	48	7.645	7.333	7.927	86	13.690	13.378	13.982
11	1.775	1.463	2.003	1.17	.750	.469	49	7.804	7.492	8.088	87	13.849	13.537	14.141
12	1.932	1.620	2.166	1.33	.844	.516	50	7.963	7.651	8.247	88	14.008	13.696	14.300
13	2.089	1.777	2.329	1.50	1.000	.625	51	8.122	7.810	8.407	89	14.168	13.856	14.459
14	2.247	1.935	2.491	1.66	1.188	.719	52	8.281	7.969	8.566	90	14.327	14.015	14.618
15	2.405	2.093	2.653	1.81	1.250	.750	53	8.440	8.128	8.725	91	14.486	14.174	14.777
16	2.563	2.251	2.814	1.98	1.375	.844	54	8.599	8.287	8.885	92	14.645	14.333	14.937
17	2.721	2.409	2.975	2.14	1.500	.938	55	8.758	8.446	9.044	93	14.804	14.492	15.096
18	2.879	2.567	3.136	2.30	1.625	1.000	56	8.917	8.605	9.203	94	14.963	14.651	15.255
19	3.038	2.726	3.297	2.45	1.750	1.063	57	9.076	8.764	9.363	95	15.122	14.810	15.414
20	3.196	2.884	3.457	2.63	1.875	1.188	58	9.236	8.924	9.522	96	15.281	14.969	15.573
21	3.355	3.043	3.618	2.78	2.063	1.281	59	9.395	9.083	9.681	97	15.440	15.128	15.733
22	3.513	3.201	3.778	2.94	2.188	1.344	60	9.554	9.242	9.841	98	15.600	15.288	15.892
23	3.672	3.360	3.938	3.09	2.250	1.375	61	9.713	9.401	10.000	99	15.759	15.447	16.051
24	3.831	3.519	4.098	3.27	2.250	1.406	62	9.872	9.560	10.159	100	15.918	15.606	16.210
25	3.989	3.677	4.258	3.42	2.281	1.438	63	10.031	9.719	10.318	101	16.077	15.765	16.370
26	4.148	3.836	4.418	3.58	2.313	1.469	64	10.190	9.878	10.478	102	16.236	15.924	16.529
27	4.307	3.995	4.578	3.73	2.375	1.500	65	10.349	10.037	10.637	103	16.395	16.083	16.688
28	4.466	4.154	4.738	3.91	2.625	1.625	66	10.508	10.196	10.796	104	16.555	16.243	16.847
29	4.625	4.313	4.898	4.06	2.750	1.688	67	10.667	10.355	10.956	105	16.714	16.402	17.006
30	4.783	4.471	5.057	4.22	2.750	1.750	68	10.826	10.514	11.115	106	16.873	16.561	17.166
31	4.942	4.630	5.217	4.38	2.813	1.781	69	10.986	10.674	11.274	107	17.032	16.720	17.324
32	5.101	4.789	5.377	4.55	3.000	1.875	70	11.145	10.833	11.434	108	17.191	16.879	17.483
33	5.260	4.948	5.536	4.70	3.375	2.125	71	11.304	10.992	11.593	109	17.350	17.038	17.643
34	5.419	5.107	5.696	4.86	3.438	2.156	72	11.463	11.151	11.752	110	17.509	17.197	17.803
35	5.578	5.266	5.856	5.02	3.563	2.219	73	11.622	11.310	11.911	111	17.668	17.357	17.961
36	5.737	5.425	6.015	5.17	3.625	2.250	74	11.781	11.469	12.071	112	17.828	17.516	18.120
37	5.896	5.584	6.175	5.34	3.688	2.281	75	11.940	11.628	12.230	113	17.987	17.675	18.280
38	6.055	5.743	6.334	5.50	3.750	2.313	76	12.099	11.787	12.389	114	18.146	17.834	18.439
39	6.214	5.902	6.494	5.66	3.750	2.344	77	12.258	11.946	12.548	115	18.305	17.993	18.598
40	6.373	6.061	6.653	5.81	3.781	2.375	78	12.417	12.105	12.708	116	18.464	18.152	18.757
41	6.532	6.220	6.813	5.97	3.813	2.406	79	12.577	12.265	12.867	117	18.623	18.311	18.917
42	6.691	6.379	6.972	6.14	4.000	2.500	80	12.736	12.424	13.026	118	18.783	18.471	19.076
43	6.850	6.538	7.132	6.30	4.250	2.625	81	12.895	12.583	13.185	119	18.942	18.630	19.235
44	7.009	6.697	7.291	6.45	4.500	2.750	82	13.054	12.742	13.345	120	19.101	18.789	19.394
45	7.168	6.856	7.451	6.61	4.750	2.875	83	13.213	12.901	13.504	Larger sizes available			

Hub length thru bore, inches

Sprocket Type	Number of Teeth	Chain Width, Number of Strands					
		1	2	3	4	5	6
B	8 to 19	.88	1.50	2.13	2.75	3.38	4.00
	20 to 46	1.00	1.63	2.25	2.88	3.50	4.13
	47 to 76	1.13	1.75	2.38	3.00	3.63	4.25
	77 to 90	1.25	2.00	2.63	3.25	3.88	4.50
	91 to 120	1.38	2.25	2.88	3.50	4.13	4.75
C	30 to 60	1.75	2.13	2.50	3.25	3.63	4.00
	61 to 82	2.00	2.38	2.75	3.50	3.88	4.25
	83 to 120	2.25	2.63	3.00	3.75	4.13	4.50

Tooth dimensions, inches

Dimension	Chain Width, Number of Strands					
	1	2	3	4	5	6
T	.168	.162	.162	.149	.149	.149
L	-	.560	.958	1.343	1.741	2.139
K	-	.399	.399	.399	.399	.399
Machined sprockets +.000", -.009"						
Hot rolled steel plate sprockets or unfinished forgings +.000", -.035"						

Recommended standard bore tolerances, keyseat dimensions, eccentricity tolerances, and similar data, page G-2.

Δ Non-functional dimension that may vary with the type of cutter used.

▲ Based on maximum hub diameter.

Drive Engineering

No. 41 chain .500" pitch

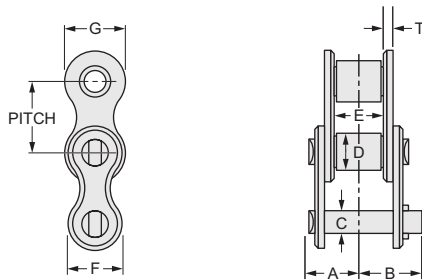

Fig. 6453

Specifications and dimensions

Chain Number	Average ultimate strength, pounds	Joint bearing area, sq. in.	Weight per foot, pounds	Dimensions, inches							
				A	B	C	D	E	F	G	T
41	2,000	.049	.27	.27	.32	.141	.306	.25	.32	.38	.05

Available only in riveted construction.

Ratings

Number of teeth, in small sprocket	Maximum bore inches	Horsepower for single strand chain ▲																			
		RPM of small sprocket																			
		50	100	200	300	400	500	700	1000	1200	1400	1600	1800	2400	3000	3500	4000	5000	6000	7000	8000
11	.875	0.13	0.24	0.44	0.64	0.82	1.01	1.37	1.88	1.71	1.36	1.11	0.93	0.61	0.43	0.34	0.28	0.20	0.15	0.12	0.10
12	.969	0.14	0.26	0.49	0.70	0.91	1.11	1.50	2.07	1.95	1.55	1.27	1.06	0.69	0.49	0.39	0.32	0.23	0.17	0.14	0.11
13	1.125	0.15	0.28	0.53	0.76	0.99	1.21	1.63	2.25	2.20	1.75	1.43	1.20	0.78	0.56	0.44	0.36	0.26	0.20	0.16	0.13
14	1.250	0.16	0.31	0.57	0.83	1.07	1.31	1.77	2.44	2.46	1.95	1.60	1.34	0.87	0.62	0.49	0.40	0.29	0.22	0.17	0.14
15	1.313	0.18	0.33	0.62	0.89	1.15	1.41	1.91	2.63	2.73	2.17	1.77	1.49	0.96	0.69	0.55	0.45	0.32	0.24	0.19	0.16
16	1.438	0.19	0.36	0.66	0.95	1.24	1.51	2.05	2.82	3.01	2.39	1.95	1.64	1.06	0.76	0.60	0.49	0.35	0.27	0.21	0.17
17	1.563	0.20	0.38	0.71	1.02	1.32	1.61	2.18	3.01	3.29	2.61	2.14	1.79	1.16	0.83	0.66	0.54	0.39	0.29	0.23	0.19
18	1.688	0.22	0.40	0.75	1.08	1.40	1.72	2.32	3.20	3.59	2.85	2.33	1.95	1.27	0.91	0.72	0.59	0.42	0.32	0.25	0
19	1.813	0.23	0.43	0.80	1.15	1.49	1.82	2.46	3.40	3.89	3.09	2.53	2.12	1.38	0.98	0.78	0.64	0.46	0.35	0.28	0
20	1.875	0.24	0.45	0.84	1.21	1.57	1.92	2.60	3.59	4.20	3.33	2.73	2.29	1.49	1.06	0.84	0.69	0.49	0.38	0.30	0
21	2.063	0.26	0.48	0.89	1.28	1.66	2.03	2.74	3.78	4.46	3.59	2.94	2.46	1.60	1.14	0.91	0.74	0.53	0.40	0.32	0
22	2.188	0.27	0.50	0.93	1.35	1.74	2.13	2.89	3.98	4.69	3.85	3.15	2.64	1.71	1.23	0.97	0.80	0.57	0.43	0.34	0
23	2.250	0.28	0.53	0.98	1.41	1.83	2.24	3.03	4.17	4.92	4.11	3.37	2.82	1.83	1.31	1.04	0.85	0.61	0.46	0.37	0
24	2.250	0.29	0.55	1.03	1.48	1.92	2.34	3.17	4.37	5.15	4.38	3.59	3.01	1.95	1.40	1.11	0.91	0.65	0.49	0.39	0
25	2.313	0.31	0.57	1.07	1.55	2.00	2.45	3.31	4.57	5.38	4.66	3.81	3.20	2.08	1.49	1.18	0.96	0.69	0.53	0	-
28	2.625	0.35	0.65	1.21	1.75	2.26	2.77	3.74	5.16	6.08	5.52	4.52	3.79	2.46	1.76	1.40	1.14	0.82	0.62	0	-
30	2.813	0.38	0.70	1.31	1.88	2.44	2.98	4.03	5.56	6.55	6.13	5.01	4.20	2.73	1.95	1.55	1.27	0.91	0.69	0	-
32	3.125	0.40	0.75	1.40	2.02	2.61	3.20	4.33	5.96	7.03	6.75	5.52	4.63	3.01	2.15	1.71	1.40	1.00	0	-	-
35	3.563	0.44	0.83	1.54	2.22	2.88	3.52	4.76	6.57	7.74	7.72	6.32	5.29	3.44	2.46	1.95	1.60	1.14	0	-	-
40	3.875	0.51	0.96	1.78	2.57	3.33	4.07	5.50	7.59	8.94	9.43	7.72	6.47	4.20	3.01	2.39	1.95	1.40	0	-	-
Lubrication type ■	A	B										C									

▲ Ratings are based on a service factor of 1. For a complete list of service factors, refer to Table 1, page C-7. The ratings listed above apply directly to lubricated, single strand, standard roller chains. To select chains that vary in design or material from standard roller chain, use the factors in Table 3, page C-7.

- Type A: Manual or drip (Maximum chain speed 300 FPM)
- Type B: Bath or disc (Maximum chain speed 2300 FPM)
- Type C: Forced (pump)

No. 41 sprockets .500" pitch

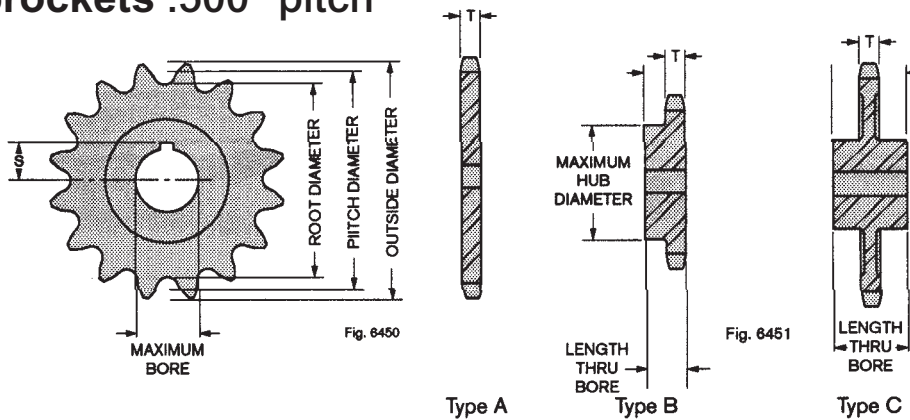

Dimensions

Number of teeth	Pitch diameter, inches	Root diameter, inches	Outside diameter, inches Δ	Maximum hub and groove diameter, inches	Maximum bore with standard keyseat, inches ▲	S max., inches	Number of teeth	Pitch diameter, inches	Root diameter, inches	Outside diameter, inches Δ	Number of teeth	Pitch diameter, inches	Root diameter, inches	Outside diameter, inches Δ
8	1.307	1.001	1.507	.77	.500	.313	46	7.327	7.021	7.609	84	13.372	13.066	13.663
9	1.462	1.156	1.674	.94	.625	.406	47	7.486	7.180	7.769	85	13.531	13.225	13.822
10	1.618	1.312	1.839	1.09	.750	.469	48	7.645	7.339	7.927	86	13.690	13.384	13.982
11	1.775	1.469	2.003	1.27	.875	.531	49	7.804	7.498	8.088	87	13.849	13.543	14.141
12	1.932	1.626	2.166	1.42	.969	.609	50	7.963	7.657	8.247	88	14.008	13.702	14.300
13	2.089	1.783	2.329	1.59	1.125	.688	51	8.122	7.816	8.407	89	14.168	13.862	14.459
14	2.247	1.941	2.491	1.75	1.250	.750	52	8.281	7.975	8.566	90	14.327	14.021	14.618
15	2.405	2.099	2.653	1.91	1.313	.813	53	8.440	8.134	8.725	91	14.486	14.180	14.777
16	2.563	2.257	2.814	2.08	1.438	.906	54	8.599	8.293	8.885	92	14.645	14.339	14.937
17	2.721	2.415	2.975	2.23	1.563	.969	55	8.758	8.452	9.044	93	14.804	14.498	15.096
18	2.879	2.573	3.136	2.39	1.688	1.031	56	8.917	8.611	9.203	94	14.963	14.657	15.255
19	3.038	2.732	3.297	2.55	1.813	1.156	57	9.076	8.770	9.363	95	15.122	14.816	15.414
20	3.196	2.890	3.457	2.72	1.875	1.188	58	9.236	8.930	9.522	96	15.281	14.975	15.573
21	3.355	3.049	3.618	2.88	2.063	1.281	59	9.395	9.089	9.681	97	15.440	15.134	15.733
22	3.513	3.207	3.778	3.03	2.188	1.344	60	9.554	9.248	9.841	98	15.600	15.294	15.892
23	3.672	3.366	3.938	3.19	2.250	1.375	61	9.713	9.407	10.000	99	15.759	15.453	16.051
24	3.831	3.525	4.098	3.36	2.250	1.438	62	9.872	9.566	10.159	100	15.918	15.612	16.210
25	3.989	3.683	4.258	3.52	2.313	1.469	63	10.031	9.725	10.318	101	16.077	15.771	16.370
26	4.148	3.842	4.418	3.67	2.375	1.500	64	10.190	9.884	10.478	102	16.236	15.930	16.529
27	4.307	4.001	4.578	3.83	2.563	1.594	65	10.349	10.043	10.637	103	16.395	16.089	16.688
28	4.466	4.160	4.738	4.00	2.625	1.625	66	10.508	10.202	10.796	104	16.555	16.249	16.847
29	4.625	4.319	4.898	4.16	2.750	1.750	67	10.667	10.361	10.956	105	16.714	16.408	17.006
30	4.783	4.477	5.057	4.31	2.813	1.781	68	10.826	10.520	11.115	106	16.873	16.567	17.166
31	4.942	4.636	5.217	4.47	2.938	1.844	69	10.986	10.680	11.274	107	17.032	16.726	17.324
32	5.101	4.795	5.377	4.64	3.125	1.938	70	11.145	10.839	11.434	108	17.191	16.885	17.483
33	5.260	4.954	5.536	4.80	3.375	2.125	71	11.304	10.998	11.593	109	17.350	17.044	17.643
34	5.419	5.113	5.696	4.95	3.438	2.156	72	11.463	11.157	11.752	110	17.509	17.203	17.803
35	5.578	5.272	4.856	5.11	3.563	2.219	73	11.622	11.316	11.911	111	17.669	17.363	17.961
36	5.737	5.431	6.015	5.27	3.625	2.250	74	11.781	11.475	12.071	112	17.828	17.522	18.120
37	5.896	5.590	6.175	5.44	3.750	2.313	75	11.940	11.634	12.230	113	17.987	17.681	18.280
38	6.055	5.749	6.334	5.59	3.750	2.344	76	12.099	11.793	12.389	114	18.146	17.840	18.439
39	6.214	5.908	6.494	5.75	3.781	2.375	77	12.258	11.952	12.548	115	18.305	17.999	18.598
40	6.373	6.067	6.653	5.91	3.875	2.438	78	12.417	12.111	12.708	116	18.464	18.158	18.757
41	6.532	6.226	6.813	6.06	4.000	2.500	79	12.577	12.271	12.867	117	18.623	18.317	18.917
42	6.691	6.385	6.972	6.23	4.250	2.625	80	12.736	12.430	13.026	118	18.783	18.477	19.076
43	6.850	6.544	7.132	6.39	4.375	2.688	81	12.895	12.589	13.185	119	18.942	18.636	19.235
44	7.009	6.703	7.291	6.55	4.625	2.750	82	13.054	12.748	13.345	120	19.101	18.795	19.394
45	7.168	6.862	7.451	6.70	4.875	2.938	83	13.213	12.907	13.504	Larger sizes available			

Hub length thru bore, inches

Sprocket Type	Number of Teeth	Hub length, inches	Sprocket Type	Number of Teeth	Hub length, inches
B	8 to 19	.88	C	30 to 60	1.75
	20 to 46	1.00		61 to 82	2.00
	47 to 76	1.13		83 to 120	2.25
	77 to 90	1.25			
	91 to 120	1.38			

Tooth dimensions, inches

T = .227" + .000", -.009" for machined sprockets.
 T = .227" + .000", -.032" for hot rolled steel plate sprockets or unfinished forgings.

Recommended standard bore tolerances, keyseat dimensions, eccentricity tolerances, and similar data, page G-2.

Δ Non-functional dimension that may vary with the type of cutter used.

▲ Based on maximum hub diameter.

Drive Engineering

No. 50 chain .625" pitch

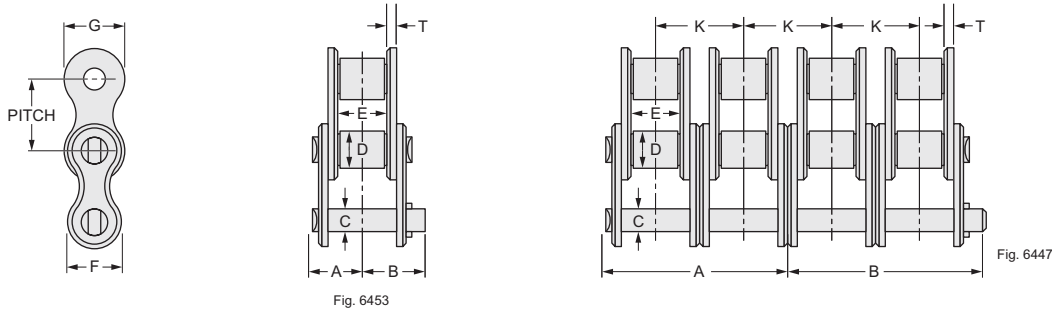

Specifications and dimensions

Chain Number	Chain Width, Number of Strands	Average ultimate strength, pounds	Joint bearing area, sq. in.	Weight per foot, pounds	Dimensions, inches								
					A	B	C	D	E	F	G	K	T
50	Single	6,100	.108	.70	.41	.48	.200	.400	.38	.52	.59	.713	.08
50-2	Double	12,000	.216	1.39	.76	.83	.200	.400	.38	.52	.59	.713	.08
50-3	Triple	18,300	.324	2.09	1.12	1.19	.200	.400	.38	.52	.59	.713	.08
50-4	Quadruple	24,400	.432	2.76	1.48	1.54	.200	.400	.38	.52	.59	.713	.08
50-5	Quintuple	30,500	.540	3.15	1.84	1.90	.200	.400	.38	.52	.59	.713	.08
50-6	Sextuple	36,600	.648	3.77	2.19	2.25	.200	.400	.38	.52	.59	.713	.08

Available only in riveted construction.

Ratings

Number of teeth, in small sprocket	Maximum bore inches	Horsepower for single strand chain ▲																			
		RPM of small sprocket																			
		50	100	300	500	900	1000	1200	1400	1600	1800	2100	2400	2700	3000	3500	4000	4500	5000	5500	6000
11	.969	0.45	0.84	2.25	3.57	6.06	6.66	7.85	8.13	6.65	5.58	4.42	3.62	3.04	2.59	2.06	1.68	1.41	1.20	1.04	0.92
12	1.125	0.49	0.92	2.47	3.92	6.65	7.31	8.62	9.26	7.58	6.35	5.04	4.13	3.46	2.95	2.34	1.92	1.61	21.37	1.19	1.04
13	1.313	0.54	1.00	2.70	4.27	7.25	7.97	9.40	10.4	8.55	7.16	5.69	4.65	3.90	3.33	2.64	2.16	1.81	1.55	1.34	0
14	1.438	0.58	1.09	2.92	4.63	7.86	8.64	10.2	11.7	9.55	8.01	6.35	5.20	4.36	3.72	2.95	2.42	2.03	1.73	1.50	0
15	1.625	0.63	1.17	3.15	4.99	8.47	9.31	11.0	12.6	10.6	8.88	7.05	5.77	4.83	4.13	3.27	2.68	2.25	1.92	1.66	0
16	1.750	0.67	1.26	3.38	5.35	9.08	9.98	11.8	13.5	11.7	9.78	7.76	6.35	5.32	4.55	3.61	2.95	2.47	2.11	1.83	0
17	1.875	0.72	1.34	3.61	5.71	9.69	10.7	12.6	14.4	12.8	10.7	8.50	6.96	5.83	4.98	3.95	3.23	2.71	2.31	2.01	0
18	2.063	0.76	1.43	3.83	6.07	10.3	11.3	13.4	15.3	13.9	11.7	9.26	7.58	6.35	5.42	4.30	3.52	2.95	2.52	0	-
19	2.250	0.81	1.51	4.07	6.44	10.9	12.0	14.2	16.3	15.3	12.7	10.0	8.22	6.89	5.88	4.67	3.82	3.20	2.73	0	-
20	2.375	0.86	1.60	4.30	6.80	11.5	12.7	15.0	17.2	16.3	13.7	10.8	8.88	7.44	6.35	5.04	4.13	3.46	2.95	0	-
21	2.563	0.90	1.69	4.53	7.17	12.2	13.4	15.8	18.1	17.6	14.7	11.7	9.55	8.01	6.84	5.42	4.44	3.72	3.18	0	-
22	2.688	0.95	1.77	4.76	7.54	12.8	14.1	16.6	19.1	18.8	15.8	12.5	10.2	8.59	7.33	5.82	4.76	3.99	3.41	0	-
23	2.813	1.00	1.86	5.00	7.91	13.4	14.8	17.4	20.0	20.1	16.9	13.4	11.0	9.18	7.84	6.22	5.09	4.27	0	-	-
24	2.875	1.04	1.95	5.23	8.29	14.1	15.5	18.2	20.9	21.4	18.0	14.3	11.7	9.78	8.35	6.63	5.42	4.55	0	-	-
25	2.906	1.09	2.03	5.47	8.66	14.7	16.2	19.0	21.9	22.8	19.1	15.2	12.4	10.4	8.88	7.05	5.77	4.83	0	-	-
28	3.250	1.23	2.30	6.18	9.79	16.6	18.3	21.5	24.7	27.0	22.6	18.0	14.7	12.3	10.5	8.35	6.84	5.73	0	-	-
30	3.563	1.33	2.48	6.66	10.5	17.9	19.7	23.2	26.6	30.0	25.1	19.9	16.3	13.7	11.7	9.26	7.58	0	-	-	-
32	3.750	1.42	2.66	7.14	11.3	19.2	21.1	24.9	28.6	32.2	27.7	22.0	18.0	15.1	12.9	10.2	8.35	0	-	-	-
35	4.125	1.57	2.93	7.86	12.5	21.1	23.2	27.4	31.5	35.5	31.6	25.1	20.6	17.2	14.7	11.7	9.55	0	-	-	-
40	5.125	1.81	3.38	9.08	14.4	24.4	26.8	31.6	36.3	41.0	38.7	30.7	25.1	21.0	18.0	14.3	0	-	-	-	-
Lubrication type ■		A			B				C												

▲ Ratings are based on a service factor of 1. For a complete list of service factors, refer to Table 1, page C-7. The ratings listed above apply directly to lubricated, single strand, standard roller chains. For multiple strand chains, apply the factors shown in the table at right. To select chains that vary in design or material from standard roller chain, use the factors in Table 3, page C-7.

■ Type A: Manual or drip (Maximum chain speed 250 FPM)
 Type B: Bath or disc (Maximum chain speed 2000 FPM)
 Type C: Forced (pump)

Number of strands	Multiple strand factor
2	1.7
3	2.5
4	3.3
5	4.1
6	5.0
7 or more	Consult Rexnord

No. 50 sprockets .625" pitch

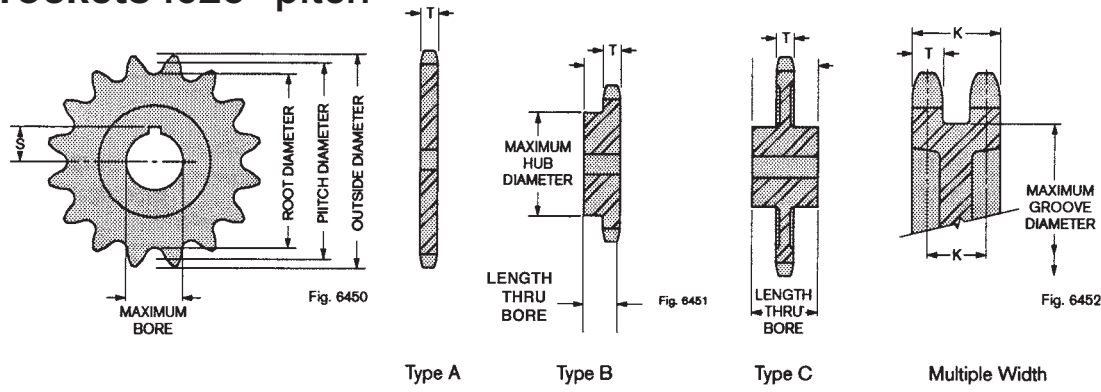

Dimensions

Number of teeth	Pitch diameter, inches	Root diameter, inches	Outside diameter, inches Δ	Maximum hub and groove diameter, inches	Maximum bore with standard keyseat, inches ▲	S max., inches	Type A				Type B				Type C				Multiple Width			
							Number of teeth	Pitch diameter, inches	Root diameter, inches	Outside diameter, inches Δ	Number of teeth	Pitch diameter, inches	Root diameter, inches	Outside diameter, inches Δ	Number of teeth	Pitch diameter, inches	Root diameter, inches	Outside diameter, inches Δ	Number of teeth	Pitch diameter, inches	Root diameter, inches	Outside diameter, inches Δ
8	1.633	1.233	1.884	.84	.563	.344	46	9.159	8.759	9.512	84	16.715	16.315	17.079								
9	1.827	1.427	2.092	1.06	.688	.438	47	9.357	8.957	9.711	85	16.914	16.514	17.278								
10	2.023	1.623	2.299	1.27	.875	.531	48	9.556	9.156	9.911	86	17.113	16.713	17.476								
11	2.219	1.819	2.504	1.47	.969	.609	49	9.755	9.355	10.110	87	17.312	16.912	17.676								
12	2.415	2.015	2.708	1.67	1.125	.688	50	9.954	9.554	10.309	88	17.511	17.111	17.874								
13	2.612	2.212	2.911	1.88	1.313	.813	51	10.153	9.753	10.508	89	17.710	17.310	18.074								
14	2.809	2.409	3.114	2.08	1.438	.906	52	10.351	9.951	10.708	90	17.909	17.509	18.273								
15	3.006	2.606	3.316	2.28	1.625	1.000	53	10.550	10.150	10.907	91	18.107	17.707	18.471								
16	3.204	2.804	3.517	2.48	1.750	1.063	54	10.749	10.349	11.106	92	18.306	17.906	18.671								
17	3.401	3.001	3.719	2.69	1.875	1.188	55	10.948	10.548	11.305	93	18.505	18.105	18.869								
18	3.599	3.199	3.919	2.89	2.063	1.281	56	11.147	10.747	11.504	94	18.704	18.304	19.069								
19	3.797	3.397	4.121	3.08	2.250	1.375	57	11.346	10.946	11.703	95	18.903	18.503	19.268								
20	3.995	3.595	4.321	3.28	2.375	1.500	58	11.544	11.144	11.903	96	19.102	18.702	19.466								
21	4.194	3.794	4.522	3.48	2.563	1.594	59	11.743	11.343	12.102	97	19.301	18.901	19.666								
22	4.392	3.992	4.722	3.69	2.688	1.656	60	11.942	11.542	12.301	98	19.500	19.100	19.864								
23	4.590	4.190	4.922	3.89	2.813	1.719	61	12.141	11.741	12.500	99	19.699	19.299	20.064								
24	4.788	4.388	5.123	4.08	2.875	1.781	62	12.340	11.940	12.699	100	19.898	19.498	20.263								
25	4.987	4.587	5.323	4.28	2.906	1.813	63	12.539	12.139	12.898	101	20.096	19.696	20.463								
26	5.185	4.785	5.523	4.48	2.938	1.875	64	12.738	12.338	13.097	102	20.295	19.895	20.661								
27	5.384	4.984	5.723	4.69	3.125	1.938	65	12.936	12.536	13.296	103	20.494	20.094	20.860								
28	5.582	5.182	5.922	4.89	3.250	2.000	66	13.135	12.735	13.496	104	20.693	20.293	21.059								
29	5.781	5.381	6.122	5.08	3.313	2.094	67	13.334	12.934	13.694	105	20.892	20.492	21.258								
30	5.979	5.579	6.321	5.28	3.563	2.219	68	13.533	13.133	13.894	106	21.091	20.691	21.457								
31	6.178	5.778	6.521	5.48	3.719	2.313	69	13.732	13.332	14.093	107	21.290	20.890	21.656								
32	6.376	5.976	6.721	5.69	3.750	2.344	70	13.931	13.531	14.292	108	21.489	21.089	21.855								
33	6.575	6.175	6.920	5.89	3.781	2.375	71	14.130	13.730	14.491	109	21.688	21.288	22.054								
34	6.774	6.374	7.120	6.08	3.875	2.438	72	14.329	13.929	14.690	110	21.887	21.487	22.253								
35	6.972	6.572	7.319	6.28	4.125	2.500	73	14.527	14.127	14.889	111	22.086	21.686	22.452								
36	7.171	6.771	7.519	6.48	4.313	2.625	74	14.726	14.326	15.088	112	22.285	21.885	22.651								
37	7.370	6.970	7.718	6.69	4.375	2.688	75	14.925	14.525	15.287	113	22.484	22.084	22.850								
38	7.569	7.169	7.918	6.88	4.500	2.750	76	15.124	14.724	15.486	114	22.683	22.283	23.049								
39	7.767	7.367	8.117	7.08	4.750	3.000	77	15.323	14.923	15.685	115	22.881	22.481	23.248								
40	7.966	7.566	8.316	7.28	5.125	3.125	78	15.522	15.122	15.884	116	23.080	22.680	23.447								
41	8.165	7.765	8.516	7.48	5.250	3.250	79	15.721	15.321	16.083	117	23.279	22.879	23.646								
42	8.363	7.963	8.715	7.67	5.500	3.375	80	15.920	15.520	16.283	118	23.478	23.078	23.845								
43	8.562	8.162	8.914	7.88	5.750	3.625	81	16.118	15.718	16.481	119	23.677	23.277	24.038								
44	8.761	8.361	9.114	8.08	5.875	3.688	82	16.317	15.917	16.681	120	23.876	23.476	24.243								
45	8.960	8.560	9.313	8.28	6.125	3.750	83	16.516	16.116	16.879	Larger sizes available											

Hub length thru bore, inches

Sprocket Type	Number of Teeth	Chain Width, Number of Strands					
		1	2	3	4	5	6
B	8 to 19	1.00	1.75	2.50	3.25	4.00	4.75
	20 to 39	1.13	1.88	2.63	3.38	4.13	4.88
	40 to 61	1.38	2.13	2.88	3.63	4.38	5.13
	62 to 90	1.63	2.38	3.13	3.88	4.63	5.38
C	91 to 120	1.88	2.63	3.38	4.13	4.88	5.63
	26 to 48	2.00	2.50	3.00	3.75	4.25	4.75
	49 to 60	2.25	2.75	3.25	4.00	4.50	5.00
	61 to 80	2.50	3.00	3.50	4.25	4.75	5.25
	81 to 120	2.75	3.25	3.75	4.50	5.00	5.50

Tooth dimensions, inches

Dimension	Chain Width, Number of Strands					
	1	2	3	4	5	6
T	3.43	.332	.332	.311	.311	.311
L	-	1.045	1.758	2.450	3.163	3.876
K	-	.713	.713	.713	.713	.713
Machined sprockets +.000", -.010"						
Hot rolled steel plate sprockets or unfinished forgings +.000", -.036"						

Tolerances for T and L

Recommended standard bore tolerances, keyseat dimensions, eccentricity tolerances, and similar data, page G-2.

▲ Non-functional dimension that may vary with the type of cutter used.

▲ Based on maximum hub diameter.

Drive Engineering

No. 60 chain .750" pitch

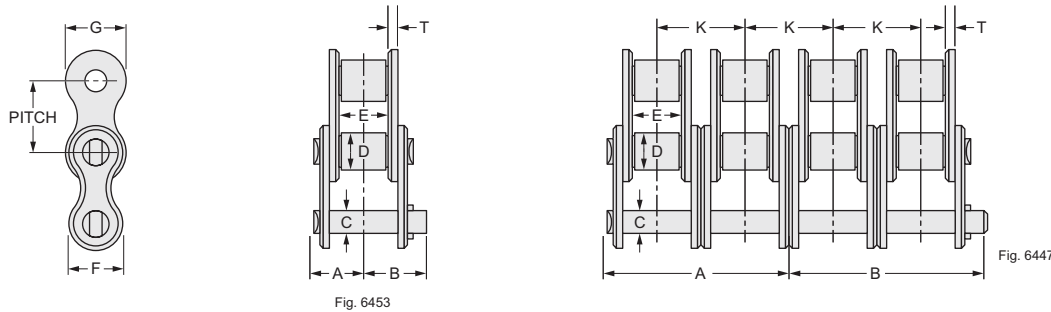

Specifications and dimensions

Chain Number	Chain Width, Number of Strands	Average ultimate strength, pounds	Joint bearing area, sq. in.	Weight per foot, pounds	Dimensions, inches								
					A	B	C	D	E	F	G	K	T
60	Single	8,500	.162	1.02	.50	.60	.234	.469	.50	.60	.71	.897	.09
60-2	Double	17,000	.324	2.00	.95	1.05	.234	.469	.50	.60	.71	.897	.09
60-3	Triple	25,500	.486	3.00	1.40	1.50	.234	.469	.50	.60	.71	.897	.09
60-4	Quadruple	34,000	.648	3.83	1.84	1.95	.234	.469	.50	.60	.71	.897	.09
60-5	Quintuple	42,500	.810	5.02	2.30	2.40	.234	.469	.50	.60	.71	.897	.09
60-6	Sextuple	51,000	.972	6.02	2.69	2.85	.234	.469	.50	.60	.71	.897	.09

Available in riveted or cottered construction.

Ratings

Number of teeth, in small sprocket	Maximum bore inches	Horsepower for single strand chain ▲																			
		RPM of small sprocket																			
		25	50	100	200	300	500	700	900	1000	1100	1200	1400	1600	1800	2000	2500	3000	3500	4000	4500
11	1.250	0.41	0.77	1.44	2.69	3.87	6.13	8.30	10.4	11.4	12.5	11.9	9.4	7.70	6.45	5.51	3.94	3.00	2.38	1.95	1.63
12	1.344	0.45	0.85	1.58	2.95	4.25	6.74	9.12	11.4	12.6	13.7	13.5	10.7	8.77	7.35	6.28	4.49	3.42	2.71	2.22	1.86
13	1.500	0.50	0.92	1.73	3.22	4.64	7.34	9.94	12.5	13.7	14.9	15.2	12.1	9.89	8.29	7.08	5.06	3.85	3.06	2.50	0
14	1.750	0.54	1.00	1.87	3.49	5.02	7.96	10.8	13.5	14.8	16.2	17.0	13.5	11.1	9.26	7.91	5.66	4.31	3.42	2.80	0
15	1.938	0.58	1.08	2.01	3.76	5.41	8.57	11.6	14.5	16.0	17.4	18.8	15.0	12.3	10.3	8.77	6.28	4.77	3.79	3.10	0
16	2.125	0.62	1.16	2.16	4.03	5.80	9.19	12.4	15.6	17.1	18.7	20.2	16.5	13.5	11.3	9.66	6.91	5.26	4.17	3.42	0
17	2.313	0.66	1.24	2.31	4.30	6.20	9.81	13.3	16.7	18.3	19.9	21.6	18.1	14.8	12.4	10.6	7.57	5.76	4.57	3.74	0
18	2.500	0.70	1.31	2.45	4.58	6.59	10.4	14.1	17.7	19.5	21.2	22.9	19.7	16.1	13.5	11.5	8.25	6.28	4.98	4.08	0
19	2.688	0.75	1.39	2.60	4.85	6.99	11.1	15.0	18.8	20.6	22.5	24.3	21.4	17.5	14.6	12.5	8.95	6.81	5.40	4.42	0
20	2.813	0.79	1.47	2.75	5.13	7.38	11.7	15.8	19.8	21.8	23.8	25.7	23.1	18.9	15.8	13.5	9.66	7.35	5.83	0	-
21	3.063	0.83	1.55	2.90	5.40	7.78	12.3	16.7	20.9	23.0	25.1	27.1	24.8	20.3	17.0	14.5	10.4	7.91	6.28	0	-
22	3.250	0.87	1.63	3.05	5.68	8.19	13.0	17.5	22.0	24.2	26.4	28.5	26.6	21.8	18.2	15.6	11.1	8.48	6.73	0	-
23	3.438	0.92	1.71	3.19	5.96	8.59	13.6	18.4	23.1	25.4	27.7	29.9	28.4	23.3	19.5	16.7	11.9	9.07	7.19	0	-
24	3.625	0.96	1.79	3.35	6.24	8.99	14.2	19.3	24.2	26.6	29.0	31.3	30.3	24.8	20.8	17.8	12.7	9.66	7.67	0	-
25	3.750	1.00	1.87	3.50	6.52	9.40	14.9	20.1	25.3	27.8	30.3	32.7	32.2	26.4	22.1	18.9	13.5	10.3	8.15	0	-
28	4.188	1.13	2.12	3.95	7.37	10.6	16.8	22.8	28.5	31.4	34.2	37.0	38.2	31.3	26.2	22.4	16.0	12.2	0	-	-
30	4.500	1.22	2.28	4.26	7.94	11.4	18.1	24.5	30.8	33.8	36.8	39.8	42.4	34.7	29.1	24.8	17.8	13.5	0	-	-
32	4.750	1.31	2.45	4.56	8.52	12.3	19.4	26.3	33.0	36.3	39.5	42.7	46.7	38.2	32.0	27.3	19.6	14.9	0	-	-
35	5.500	1.44	2.69	5.03	9.38	13.5	21.4	29.0	36.3	39.9	43.5	47.1	53.4	43.7	36.6	31.3	22.4	17.0	0	-	-
40	6.250	1.67	3.11	5.81	10.8	15.6	24.7	33.5	42.0	46.1	50.3	54.4	62.5	53.4	44.7	38.2	27.3	0	-	-	-
Lubrication type ■		A			B					C											

▲ Ratings are based on a service factor of 1. For a complete list of service factors, refer to Table 1, page C-7. The ratings listed above apply directly to lubricated, single strand, standard and heavy series roller chains. For multiple strand chains, apply the factors shown in the table at right. To select chains that vary in design or material from standard roller chain, use the factors in Table 3, page C-7.

■ Type A: Manual or drip (Maximum chain speed 220 FPM)
 Type B: Bath or disc (Maximum chain speed 1800 FPM)
 Type C: Forced (pump)

Multiple strand factors

Number of strands	Multiple strand factor
2	1.7
3	2.5
4	3.3
5	4.1
6	5.0
7 or more	Consult Rexnord

No. 60 sprockets .750" pitch

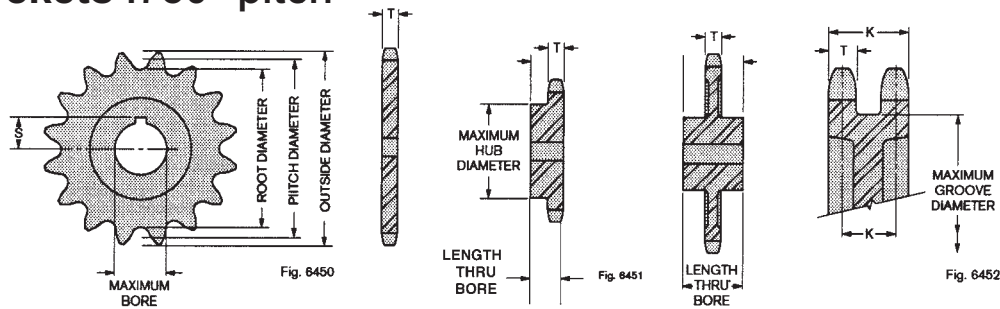

Dimensions

Number of teeth	Pitch diameter, inches	Root diameter, inches	Outside diameter, inches Δ	Maximum hub and groove diameter, inches	Maximum bore with standard keyseat, inches ▲	S max., inches	Number of teeth	Pitch diameter, inches	Root diameter, inches	Outside diameter, inches Δ	Number of teeth	Pitch diameter, inches	Root diameter, inches	Outside diameter, inches Δ
8	1.960	1.491	2.261	1.03	.625	.406	46	10.990	10.522	11.414	84	20.058	19.589	20.495
9	2.193	1.724	2.510	1.28	.875	.531	47	11.229	10.760	11.654	85	20.297	19.828	20.733
10	2.427	1.958	2.759	1.52	1.000	.625	48	11.467	10.999	11.893	86	20.536	20.067	20.972
11	2.662	2.193	3.005	1.77	1.250	.750	49	11.706	11.237	12.132	87	20.774	20.305	21.211
12	2.898	2.429	3.249	2.02	1.344	.828	50	11.945	11.476	12.371	88	21.013	20.544	21.449
13	3.134	2.665	3.493	2.25	1.500	.938	51	12.183	11.714	12.610	89	21.252	20.783	21.689
14	3.371	2.902	3.737	2.50	1.750	1.063	52	12.422	11.953	12.849	90	21.490	21.021	21.927
15	3.607	3.139	3.979	2.75	1.938	1.219	53	12.660	12.192	13.088	91	21.729	21.260	22.166
16	3.844	3.376	4.220	2.98	2.125	1.313	54	12.899	12.430	13.327	92	21.968	21.499	22.405
17	4.082	3.613	4.463	3.22	2.313	1.469	55	13.137	12.669	13.566	93	22.206	21.737	22.643
18	4.319	3.850	4.703	3.47	2.500	1.563	56	13.376	12.907	13.805	94	22.445	21.976	22.883
19	4.557	4.088	4.945	3.70	2.688	1.656	57	13.615	13.146	14.044	95	22.683	22.214	23.121
20	4.794	4.326	5.186	3.95	2.813	1.719	58	13.853	13.385	14.283	96	22.922	22.453	23.360
21	5.032	4.563	5.426	4.19	3.063	1.906	59	14.092	13.623	14.522	97	23.161	22.692	23.599
22	5.270	4.801	5.666	4.44	3.250	2.000	60	14.331	13.862	14.761	98	23.400	22.931	23.837
23	5.508	5.039	5.906	4.67	3.438	2.156	61	14.569	14.100	15.000	99	23.638	23.169	24.077
24	5.746	5.277	6.147	4.91	3.625	2.250	62	14.808	14.339	15.239	100	23.877	23.408	24.315
25	5.984	5.515	6.387	5.16	3.750	2.313	63	15.046	14.577	15.478	101	24.116	23.647	24.554
26	6.222	5.753	6.627	5.39	3.875	2.438	64	15.285	14.816	15.716	102	24.354	23.885	24.793
27	6.460	5.992	6.867	5.63	4.000	2.500	65	15.524	15.055	15.956	103	24.593	24.124	25.032
28	6.699	6.230	7.106	5.88	4.188	2.594	66	15.762	15.293	16.195	104	24.832	24.363	25.271
29	6.937	6.468	7.346	6.11	4.375	2.688	67	16.001	15.532	16.433	105	25.071	24.602	25.509
30	7.175	6.706	7.586	6.34	4.500	2.750	68	16.240	15.771	16.673	106	25.309	24.840	25.748
31	7.413	6.945	7.826	6.59	4.563	2.906	69	16.478	16.009	16.911	107	25.548	25.079	25.987
32	7.652	7.183	8.065	6.83	4.750	3.000	70	16.717	16.248	17.150	108	25.787	25.318	26.226
33	7.890	7.421	8.304	7.06	5.125	3.188	71	16.956	16.487	17.389	109	26.025	25.556	26.465
34	8.129	7.660	8.544	7.31	5.375	3.313	72	17.194	16.725	17.628	110	26.264	25.795	26.704
35	8.367	7.898	8.783	7.55	5.500	3.375	73	17.433	16.964	17.867	111	26.503	26.034	26.942
36	8.605	8.137	9.023	7.78	5.625	3.563	74	17.671	17.203	18.106	112	26.742	26.273	27.181
37	8.844	8.375	9.262	8.03	5.875	3.688	75	17.910	17.441	18.344	113	26.980	26.511	27.420
38	9.082	8.613	9.501	8.27	6.000	3.750	76	18.149	17.680	18.584	114	27.219	26.750	27.659
39	9.321	8.852	9.740	8.50	6.125	3.813	77	18.387	17.918	18.822	115	27.458	26.989	27.898
40	9.559	9.090	9.980	8.75	6.250	3.875	78	18.626	18.157	19.061	116	27.697	27.228	28.136
41	9.798	9.329	10.219	8.98	6.375	3.938	79	18.865	18.396	19.300	117	27.936	27.467	28.375
42	10.036	9.567	10.458	9.22	6.500	4.000	80	19.103	18.635	19.539	118	28.174	27.705	28.614
43	10.275	9.806	10.697	9.47	6.875	4.188	81	19.342	18.873	19.778	119	28.413	27.944	28.853
44	10.513	10.044	10.937	9.70	7.125	4.313	82	19.581	19.112	20.017	120	28.651	28.182	29.091
45	10.752	10.283	11.176	9.94	7.375	4.438	83	19.819	19.350	20.255	Larger sizes available			

Hub length thru bore, inches

Sprocket Type	Number of Teeth	Chain Width, Number of Strands					
		1	2	3	4	5	6
B	8 to 30	1.25	2.13	3.00	4.00	4.88	5.75
	31 to 50	1.50	2.38	3.25	4.25	5.13	6.00
	51 to 83	1.75	2.63	3.50	4.50	5.38	6.25
	84 to 120	2.00	2.88	3.75	4.75	5.63	6.50
C	20 to 40	2.25	2.75	3.75	4.75	5.50	6.25
	41 to 80	2.50	3.00	3.75	4.75	5.50	6.25
	81 to 120	3.00	3.50	4.00	5.00	5.75	6.50

Tooth dimensions, inches

Dimension	Chain Width, Number of Strands					
	1	2	3	4	5	6
T	.459	.444	.444	.418	.418	.418
L	-	1.342	2.240	3.112	4.010	4.908
K	-	.897	.897	.897	.897	.897
Machined sprockets +.000", -.011"						
Tolerances for T and L Hot rolled steel plate sprockets or unfinished forgings +.000", -.036"						

Recommended standard bore tolerances, keyseat dimensions, eccentricity tolerances, and similar data, page G-2.

Δ Non-functional dimension that may vary with the type of cutter used.

▲ Based on maximum hub diameter.

Drive Engineering

No. 80 chain 1.000" pitch

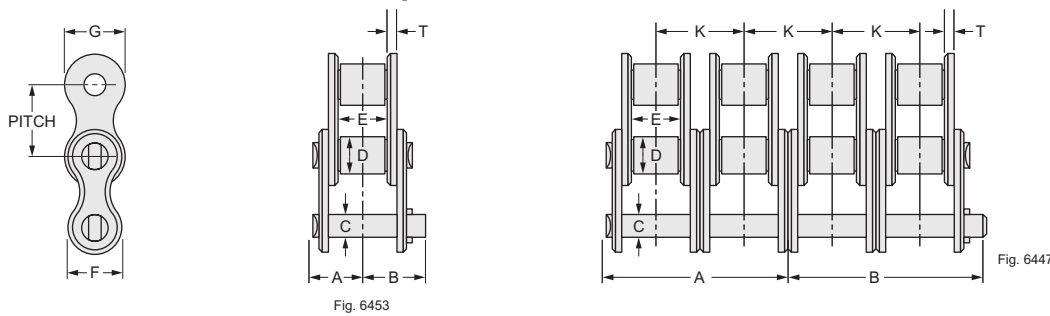

Specifications and dimensions

Chain Number	Chain Width, Number of Strands	Average ultimate strength, pounds	Joint bearing area, sq. in.	Weight per foot, pounds	Dimensions, inches								
					A	B	C	D	E	F	G	K	T
80	Single	14,500	.275	1.67	.63	.74	.313	.625	.63	.75	.91	1.153	.13
80-2	Double	29,000	.550	3.31	1.21	1.30	.313	.625	.63	.75	.91	1.153	.13
80-3	Triple	43,500	.825	4.97	1.78	1.87	.313	.625	.63	.75	.91	1.153	.13
80-4	Quadruple	58,000	1.100	6.76	2.35	2.44	.313	.625	.63	.75	.91	1.153	.13
80-5	Quintuple	72,500	1.375	8.21	2.92	3.03	.313	.625	.63	.75	.91	1.153	.13
80-6	Sextuple	87,000	1.650	9.84	3.50	3.61	.313	.625	.63	.75	.91	1.153	.13

Available in riveted or cottered construction.

Ratings

Number of teeth, in small sprocket	Maximum bore inches	Horsepower for single strand chain ▲																			
		RPM of small sprocket																			
		25	50	100	200	300	400	500	700	900	1000	1200	1400	1600	1800	2000	2200	2400	2700	3000	3400
11	1.625	0.97	1.80	3.36	6.28	9.04	11.7	14.3	19.4	23.0	19.6	14.9	11.8	9.69	8.12	6.93	6.01	5.27	4.42	3.77	1.70
12	1.750	1.06	1.98	3.69	6.89	9.93	12.9	15.7	21.3	26.2	22.3	17.0	13.5	11.0	9.25	7.90	6.85	6.01	5.04	4.30	0
13	2.000	1.16	2.16	4.03	7.52	10.8	14.0	17.1	23.2	29.1	25.2	19.2	15.2	12.5	10.4	8.91	7.72	6.78	5.68	4.85	0
14	2.250	1.25	2.34	4.36	8.14	11.7	15.2	18.6	25.1	31.5	28.2	21.4	17.0	13.9	11.7	9.96	8.63	7.57	6.35	5.42	0
15	2.563	1.35	2.52	4.70	8.77	12.6	16.4	20.0	27.1	34.0	31.2	23.8	18.9	15.4	12.9	11.0	9.57	8.40	7.04	6.01	0
16	2.875	1.45	2.70	5.04	9.41	13.5	17.6	21.5	29.0	36.4	34.4	26.2	20.8	17.0	14.2	12.2	10.5	9.25	7.76	6.62	0
17	3.125	1.55	2.88	5.38	10.0	14.5	18.7	22.9	31.0	38.9	37.7	28.7	22.7	18.6	15.6	13.3	11.5	10.1	8.49	7.25	0
18	3.375	1.64	3.07	5.72	10.7	15.4	19.9	24.4	33.0	41.4	41.1	31.2	24.8	20.3	17.0	14.5	12.6	11.0	9.25	7.90	0
19	3.688	1.74	3.25	6.07	11.3	16.3	21.1	25.8	35.0	43.8	44.5	33.9	26.9	22.0	18.4	15.7	13.6	12.0	10.0	8.57	0
20	3.813	1.84	3.44	6.41	12.0	17.2	22.3	27.3	37.0	46.3	48.1	36.6	29.0	23.8	19.9	17.0	14.7	12.9	10.8	0	-
21	4.125	1.94	3.62	6.76	12.6	18.2	23.5	28.8	39.0	48.9	51.7	39.4	31.2	25.6	21.4	18.3	15.9	13.9	11.7	0	-
22	4.438	2.04	3.81	7.11	13.3	19.1	24.8	30.3	41.0	51.4	55.5	42.2	33.5	27.4	23.0	19.6	17.0	14.9	12.5	0	-
23	4.625	2.14	4.00	7.46	13.9	20.1	26.0	31.8	43.0	53.9	59.3	45.1	35.8	29.3	24.6	21.0	18.2	15.9	13.4	0	-
24	4.688	2.24	4.19	7.81	14.6	21.0	27.2	33.2	45.0	56.4	62.0	48.1	38.2	31.2	26.2	22.3	19.4	17.0	14.2	0	-
25	4.750	2.34	4.37	8.16	15.2	21.9	28.4	34.7	47.0	59.0	64.8	51.1	40.6	33.2	27.8	23.8	20.6	18.1	15.1	0	-
28	5.375	2.65	4.94	9.23	17.2	24.8	32.1	39.3	53.2	66.7	73.3	60.6	48.1	39.4	33.0	28.2	24.4	21.4	0	-	-
30	5.750	2.85	5.33	9.94	18.5	26.7	34.6	42.3	57.3	71.8	78.9	67.2	53.3	43.6	36.6	31.2	27.1	23.8	0	-	-
32	6.313	3.06	5.71	10.7	19.9	28.6	37.1	45.4	61.4	77.0	84.6	74.0	58.7	48.1	40.3	34.4	29.8	26.2	0	-	-
35	7.750	3.37	6.29	11.7	21.9	31.6	40.9	50.0	67.6	84.8	93.3	84.7	67.2	55.0	46.1	39.4	34.1	0	-	-	-
40	9.375	3.89	7.27	13.6	25.3	36.4	47.2	57.7	78.1	99.01	108	103	82.1	67.2	56.3	48.1	20.0	0	-	-	-
Lubrication type ■		A			B					C											

The dotted line indicates the point at which pin and bushing galling is likely to begin. When the desired selection falls within the shaded area, consult Rexnord for guidance.

▲ Ratings are based on a service factor of 1. For a complete list of service factors, refer to Table 1, page C-7. The ratings listed above apply directly to lubricated, single strand, standard and heavy series roller chains. For multiple strand chains, apply the factors shown in the table at right. To select chains that vary in design or material from standard roller chain, use the factors in Table 3, page C-7.

■ Type A: Manual or drip (Maximum chain speed 170 FPM)
 Type B: Bath or disc (Maximum chain speed 1500 FPM)
 Type C: Forced (pump)

Multiple strand factors

Number of strands	Multiple strand factor
2	1.7
3	2.5
4	3.3
5	4.1
6	5.0
7 or more	Consult Rexnord

No. 80 sprockets 1.000" pitch

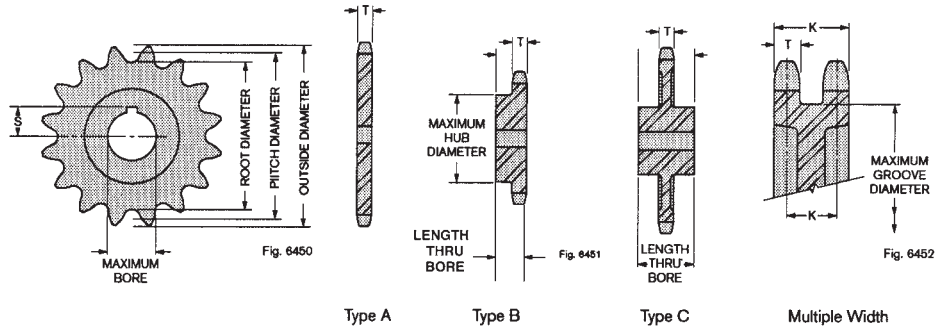

Dimensions

Number of teeth	Pitch diameter, inches	Root diameter, inches	Outside diameter, inches Δ	Maximum hub and groove diameter, inches	Maximum bore with standard keyseat, inches \blacktriangle	S max., inches	Number of teeth	Pitch diameter, inches	Root diameter, inches	Outside diameter, inches Δ	Number of teeth	Pitch diameter, inches	Root diameter, inches	Outside diameter, inches Δ
8	2.613	1.988	3.014	1.38	.875	.563	46	14.654	14.029	15.219	84	26.744	26.119	27.326
9	2.924	2.299	3.347	1.72	1.188	.719	47	14.972	14.347	15.538	85	27.063	26.437	27.644
10	3.236	2.611	3.678	2.05	1.313	.813	48	15.290	14.665	15.857	86	27.381	26.756	27.962
11	3.549	2.924	4.006	2.38	1.625	1.000	49	15.608	14.983	16.176	87	27.699	27.074	28.281
12	3.864	3.239	4.332	2.70	1.750	1.063	50	15.926	15.301	16.495	88	28.017	27.392	28.599
13	4.179	3.554	4.657	3.02	2.000	1.250	51	16.244	15.619	16.813	89	28.335	27.710	28.918
14	4.494	3.869	4.982	3.34	2.250	1.375	52	16.562	15.937	17.132	90	28.654	28.029	29.236
15	4.810	4.185	5.305	3.67	2.563	1.594	53	16.880	16.255	17.451	91	28.972	28.347	29.554
16	5.126	4.501	5.627	3.98	2.875	1.813	54	17.198	16.573	17.769	92	29.290	28.665	29.873
17	5.442	4.817	5.950	4.31	3.125	1.938	55	17.517	16.892	18.088	93	29.608	28.983	30.191
18	5.759	5.134	6.271	4.54	3.375	2.125	56	17.836	17.210	18.406	94	29.926	29.301	30.510
19	6.076	5.451	6.593	4.95	3.688	2.281	57	18.153	17.528	18.725	95	30.245	29.620	30.828
20	6.393	5.768	6.914	5.28	3.813	2.344	58	18.471	17.846	19.044	96	30.563	29.938	31.146
21	6.710	6.085	7.235	5.59	4.125	2.563	59	18.789	18.164	19.363	97	30.881	30.256	31.465
22	7.027	6.402	7.555	5.92	4.438	2.719	60	19.107	18.482	19.681	98	31.199	30.574	31.783
23	7.344	6.719	7.875	6.23	4.625	2.813	61	19.426	18.800	20.000	99	31.518	30.893	32.102
24	7.661	7.035	8.196	6.56	4.688	2.938	62	19.744	19.119	20.318	100	31.836	31.211	32.420
25	7.979	7.354	8.516	6.88	4.750	3.000	63	20.062	19.347	20.637	101	32.154	31.529	32.739
26	8.296	7.671	8.836	7.20	5.063	3.156	64	20.380	19.755	20.955	102	32.473	31.848	33.057
27	8.614	7.989	9.156	7.52	5.125	3.188	65	20.698	20.073	21.274	103	32.791	32.166	33.376
28	8.932	8.307	9.475	7.84	5.375	3.313	66	21.016	20.391	21.593	104	33.109	32.484	33.694
29	9.249	8.624	9.795	8.16	5.625	3.563	67	21.335	20.710	21.911	105	33.427	32.802	34.012
30	9.567	8.942	10.114	8.48	5.750	3.625	68	21.653	21.028	22.230	106	33.746	33.121	34.331
31	9.885	9.260	10.434	8.80	6.000	3.750	69	21.971	21.346	22.548	107	34.064	33.439	34.649
32	10.202	9.577	10.753	9.11	6.313	3.906	70	22.289	21.664	22.867	108	34.382	33.757	34.968
33	10.520	9.895	11.072	9.44	7.000	4.250	71	22.607	21.982	23.185	109	34.701	34.076	35.286
34	10.838	10.213	11.392	9.75	7.563	4.656	72	22.926	22.301	23.504	110	35.019	34.394	35.605
35	11.156	10.531	11.711	10.08	7.750	4.750	73	23.244	22.619	23.822	111	35.337	34.712	35.923
36	11.474	10.849	12.030	10.39	8.063	4.906	74	23.562	22.937	24.141	112	35.655	35.030	36.241
37	11.792	11.167	12.349	10.72	8.250	5.000	75	23.880	23.255	24.459	113	35.974	35.349	36.560
38	12.110	11.485	12.668	11.03	8.500	5.125	76	24.198	23.573	24.778	114	36.292	35.667	36.878
39	12.428	11.803	12.987	11.34	9.125	5.438	77	24.517	23.892	25.096	115	36.610	35.985	37.197
40	12.746	12.121	13.306	11.67	9.375	5.563	78	24.835	24.210	25.415	116	36.929	36.304	37.515
41	13.064	12.439	13.625	11.98	9.500	5.625	79	25.153	24.528	25.733	117	37.247	36.622	37.833
42	13.382	12.757	13.944	12.31	9.625	5.688	80	25.471	24.846	26.052	118	37.565	36.940	38.152
43	13.700	13.075	14.263	12.63	9.750	5.750	81	25.790	25.165	26.370	119	37.883	37.258	38.470
44	14.018	13.393	14.582	12.94	9.813	5.906	82	26.108	25.483	26.689	120	38.201	37.576	38.788
45	14.336	13.711	14.901	13.27	9.875	5.938	83	26.426	25.801	27.007	Larger sizes available			

Hub length thru bore, inches

Sprocket Type	Number of Teeth	Chain Width, Number of Strands					
		1	2	3	4	5	6
B	8 to 15	1.38	2.50	3.63	4.75	5.88	7.00
	16 to 24	1.63	2.75	3.88	5.00	6.13	7.25
	25 to 37	1.88	3.00	4.13	5.25	6.38	7.50
	38 to 60	2.13	3.25	4.38	5.50	6.63	7.75
	61 to 88	2.38	3.50	4.63	5.75	6.88	8.00
C	89 to 120	2.63	3.75	4.88	6.00	7.13	8.25
	18 to 36	2.50	3.25	4.50	5.75	6.50	7.25
	37 to 64	3.00	3.75	4.50	5.75	6.50	7.25
	65 to 80	3.25	4.00	4.75	6.00	6.75	7.50
	81 to 120	3.50	4.25	5.00	6.25	7.00	7.75

Tooth dimensions, inches

Dimension	Chain Width, Number of Strands					
	1	2	3	4	5	6
T	.575	.557	.557	.526	.526	.526
L	-	1.709	2.861	3.982	5.134	6.286
K	-	1.153	1.153	1.153	1.153	1.153

Tolerances for T and L
 Machined sprockets +.000", -.012"
 Hot rolled steel plate sprockets or unfinished forgings +.000", -.040"

Recommended standard bore tolerances, keyseat dimensions, eccentricity tolerances, and similar data, page G-2.
 Δ Non-functional dimension that may vary with the type of cutter used.
 \blacktriangle Based on maximum hub diameter.

Drive Engineering

No. 100 chain 1.250" pitch

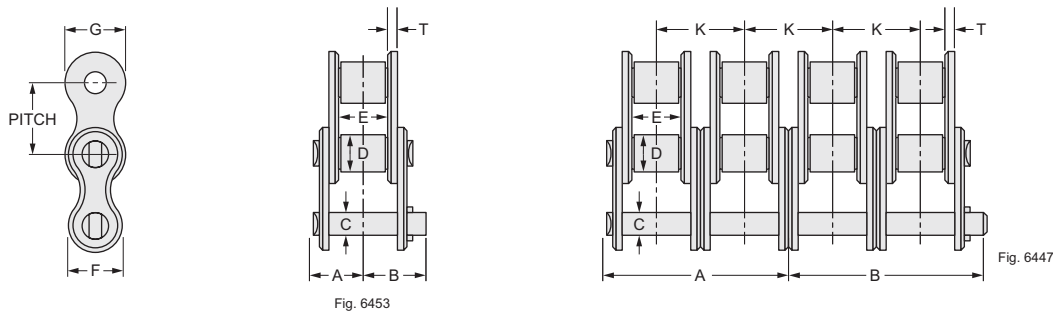

Specifications and dimensions

Chain Number	Chain Width, Number of Strands	Average ultimate strength, pounds	Joint bearing area, sq. in.	Weight per foot, pounds	Dimensions, inches								
					A	B	C	D	E	F	G	K	T
100	Single	26,000	.401	2.72	.76	.89	.375	.750	.75	.97	1.13	1.408	.16
100-2	Double	52,000	.802	5.19	1.46	1.59	.375	.750	.75	.97	1.13	1.408	.16
100-3	Triple	78,000	1.203	7.67	2.16	2.29	.375	.750	.75	.97	1.13	1.408	.16
100-4	Quadruple	104,000	1.604	10.1	2.86	2.99	.375	.750	.75	.97	1.13	1.408	.16
100-5	Quintuple	130,000	2.005	12.7	3.56	3.69	.375	.750	.75	.97	1.13	1.408	.16
100-6	Sextuple	156,000	2.406	15.2	4.26	4.39	.375	.750	.75	.97	1.13	1.408	.16

Available in riveted and cottered construction.

Ratings

Number of teeth, in small sprocket	Maximum bore inches	Horsepower for single strand chain ▲																			
		RPM of small sprocket																			
		25	50	100	200	300	400	500	600	700	800	900	1000	1200	1400	1600	1800	2000	2200	2400	2600
11	2.000	1.85	3.45	6.44	12.0	17.3	22.4	27.4	32.3	37.1	32.8	27.5	23.4	17.8	14.2	11.6	9.71	8.29	7.19	6.31	1.29
12	2.250	2.03	3.79	7.08	13.2	19.0	24.6	30.1	35.5	40.8	37.3	31.3	26.7	20.3	16.1	13.2	11.1	9.45	8.19	7.19	0
13	2.500	2.22	4.13	7.72	14.4	20.7	26.9	32.8	38.7	44.5	42.1	35.3	30.1	22.9	18.2	14.9	12.5	10.6	9.23	8.10	0
14	2.813	2.40	4.48	8.36	15.6	22.5	29.1	35.6	41.9	48.2	47.0	39.4	33.7	25.6	20.3	16.6	13.9	11.9	10.3	9.05	0
15	3.250	2.59	4.83	9.01	16.8	24.2	31.4	38.3	45.2	51.9	52.2	43.7	37.3	28.4	22.5	18.4	15.5	13.2	11.4	10.0	0
16	3.500	2.77	5.17	9.66	18.0	26.0	33.6	41.1	48.4	55.6	57.5	48.2	41.1	31.3	24.8	20.3	17.0	14.5	12.6	11.1	0
17	3.813	2.96	5.52	10.3	19.2	27.7	35.9	43.9	51.7	59.4	63.0	52.8	45.0	34.3	27.2	22.3	18.7	15.9	13.8	0.79	0
18	4.188	3.15	5.88	11.0	20.5	29.5	38.2	46.7	55.0	62.3	68.6	57.5	49.1	37.3	29.6	24.2	20.3	17.4	15.0	0	-
19	4.563	3.34	6.23	11.6	21.7	31.2	40.5	49.5	58.3	67.0	74.4	62.3	53.2	40.5	32.1	26.3	22.0	18.8	16.3	0	-
20	4.875	3.53	6.58	12.3	22.9	33.0	42.8	52.3	61.6	70.8	79.8	67.3	57.5	43.7	34.7	28.4	23.8	20.3	17.6	0	-
21	5.250	3.72	6.94	13.0	24.2	34.8	45.1	55.1	65.0	74.6	84.2	72.4	61.8	47.0	37.3	30.6	25.6	21.9	19.0	0	-
22	5.625	3.91	7.30	13.6	25.4	36.6	47.4	58.0	68.3	78.5	88.5	77.7	66.3	50.4	40.0	32.8	27.5	23.4	20.3	0	-
23	5.813	4.10	7.66	14.3	26.7	38.4	49.8	60.8	71.7	82.3	92.8	83.0	70.9	53.9	42.8	35.0	29.4	25.1	7.74	0	-
24	6.000	4.30	8.02	15.0	27.9	40.2	52.1	63.7	75.0	86.2	97.2	88.5	75.6	57.5	45.6	37.3	31.3	26.7	0	-	-
25	6.125	4.49	8.38	15.6	29.2	42.0	54.4	66.6	78.4	90.1	102	94.1	80.3	61.1	48.5	39.7	33.3	28.4	0	-	-
28	7.000	5.07	9.47	17.7	33.0	47.5	61.5	75.2	88.6	102	115	112	95.2	72.4	57.5	47.0	39.4	33.7	0	-	-
30	7.625	5.47	10.2	19.0	35.5	51.2	66.3	81.0	95.5	110	124	124	106	80.3	63.7	52.2	43.7	10.0	0	-	-
32	8.250	5.86	10.9	20.4	38.1	54.91	71.1	86.9	102	118	133	136	116	88.5	70.2	57.5	45.2	0	-	-	-
35	9.125	6.46	12.0	22.5	42.0	60.4	78.3	95.7	113	130	146	156	133	101	80.3	65.8	55.1	0	-	-	-
40	-	7.46	13.9	26.0	48.5	69.8	90.4	111	130	150	169	188	163	124	98.1	80.3	0	-	-	-	-
Lubrication type ■		A			B						C										

The dotted line indicates the point at which pin and bushing galling is likely to begin. When the desired selection falls within the shaded area, consult Rexnord for guidance.

▲ Ratings are based on a service factor of 1. For a complete list of service factors, refer to Table 1, page C-7. The ratings listed above apply directly to lubricated, single strand, standard and heavy series roller chains. For multiple strand chains, apply the factors shown in the table at right. To select chains that vary in design or material from standard roller chain, use the factors in Table 3, page C-7.

■ Type A: Manual or drip (Maximum chain speed 150 FPM)
 Type B: Bath or disc (Maximum chain speed 1300 FPM)
 Type C: Forced (pump)

Multiple strand factors

Number of strands	Multiple strand factor
2	1.7
3	2.5
4	3.3
5	4.1
6	5.0
7 or more	Consult Rexnord

No. 100 sprockets 1.250" pitch

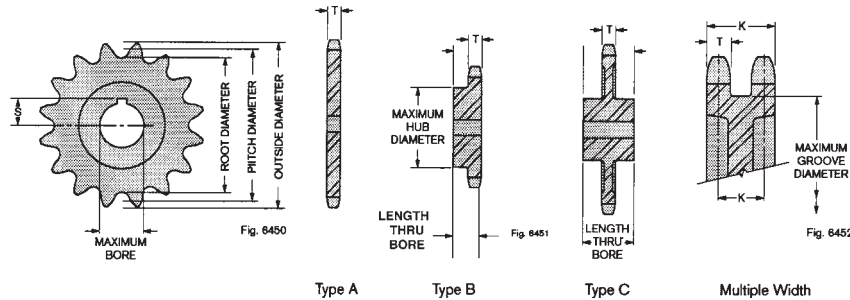

Dimensions

Type A							Type B				Type C				Multiple Width			
Number of teeth	Pitch diameter, inches	Root diameter, inches	Outside diameter, inches Δ	Maximum hub and groove diameter, inches	Maximum bore with standard keyseat, inches ▲	S max., inches	Number of teeth	Pitch diameter, inches	Root diameter, inches	Outside diameter, inches Δ	Number of teeth	Pitch diameter, inches	Root diameter, inches	Outside diameter, inches Δ	Number of teeth	Pitch diameter, inches	Root diameter, inches	Outside diameter, inches Δ
8	3.266	2.516	3.768	1.73	1.188	.719	46	18.317	17.567	19.024	84	33.430	32.680	34.158				
9	3.655	2.905	4.184	2.14	1.375	.844	47	18.715	17.965	19.423	85	33.828	33.078	34.555				
10	4.045	3.295	4.598	2.56	1.625	1.000	48	19.122	18.362	19.821	86	34.226	33.476	34.953				
11	4.437	3.687	5.008	2.97	2.000	1.250	49	19.510	18.760	20.220	87	34.624	33.874	35.351				
12	4.830	4.080	5.415	3.38	2.250	1.375	50	19.908	19.168	20.619	88	35.021	34.271	35.749				
13	5.223	4.473	5.821	3.78	2.500	1.563	51	20.305	19.555	21.016	89	35.419	34.669	36.148				
14	5.617	4.867	6.228	4.19	2.813	1.719	52	20.703	19.953	21.415	90	35.817	35.067	36.545				
15	6.012	5.262	6.631	4.59	3.250	2.000	53	21.100	20.350	21.814	91	36.215	35.465	36.943				
16	6.407	5.657	7.034	5.00	3.500	2.188	54	21.498	20.748	22.211	92	36.612	35.862	37.341				
17	6.803	6.053	7.438	5.41	3.813	2.344	55	21.896	21.146	22.610	93	37.010	36.260	37.739				
18	7.198	6.448	7.839	5.80	4.188	2.594	56	22.293	21.543	23.008	94	37.408	36.658	38.138				
19	7.595	6.845	8.241	6.20	4.563	2.781	57	22.691	21.941	23.406	95	37.806	37.056	38.535				
20	7.991	7.241	8.643	6.61	4.875	3.063	58	23.089	22.339	23.805	96	38.203	37.453	38.933				
21	8.387	7.637	9.044	7.00	5.250	3.250	59	23.486	22.736	24.204	97	38.601	37.851	39.331				
22	8.783	8.033	9.444	7.41	5.625	3.438	60	23.884	23.134	24.601	98	38.999	38.249	39.729				
23	9.180	8.430	9.844	7.81	5.813	3.656	61	24.282	23.532	25.000	99	39.397	38.647	40.128				
24	9.577	8.827	10.245	8.20	6.000	3.750	62	24.680	23.930	25.398	100	39.795	39.045	40.525				
25	9.973	9.223	10.645	8.61	6.125	3.813	63	25.077	24.327	25.796	101	40.193	39.443	40.924				
26	10.370	9.620	11.045	9.02	6.188	3.844	64	25.475	24.725	26.194	102	40.591	39.841	41.321				
27	10.767	10.017	11.445	9.41	6.375	4.063	65	25.873	25.123	26.592	103	40.989	40.239	41.720				
28	11.164	10.414	11.844	9.81	7.000	4.250	66	26.271	25.521	26.991	104	41.386	40.636	42.118				
29	11.561	10.811	12.244	10.20	7.250	4.375	67	26.668	25.918	27.389	105	41.784	41.034	42.515				
30	11.958	11.208	12.643	10.61	7.625	4.563	68	27.066	26.316	27.788	106	42.182	41.432	42.914				
31	12.356	11.606	13.043	11.00	7.750	4.750	69	27.464	26.714	28.185	107	42.580	41.820	43.311				
32	12.753	12.003	13.441	11.41	8.250	5.000	70	27.862	27.112	28.584	108	42.978	42.228	43.710				
33	13.150	12.400	13.840	11.80	8.375	5.063	71	28.259	27.509	28.981	109	43.376	42.626	44.108				
34	13.547	12.797	14.240	12.20	9.000	5.375	72	28.657	27.907	29.380	110	43.774	43.024	44.506				
35	13.945	12.195	14.639	12.61	9.125	5.438	73	29.055	28.305	29.778	111	44.171	43.421	44.904				
36	14.342	13.592	15.038	13.00	-	-	74	29.453	28.703	30.176	112	44.569	43.819	45.301				
37	14.740	13.990	15.436	13.41	-	-	75	29.850	29.100	30.574	113	44.967	44.217	45.700				
38	15.137	14.387	15.835	13.80	-	-	76	30.248	29.498	30.973	114	45.365	44.615	46.098				
39	15.534	14.784	16.234	14.20	-	-	77	30.646	29.896	31.370	115	45.763	45.013	46.496				
40	15.932	15.182	16.633	14.59	-	-	78	31.044	30.294	31.769	116	46.161	45.411	46.894				
41	16.329	15.579	17.031	15.00	-	-	79	31.441	30.691	32.166	117	46.559	45.809	47.291				
42	16.727	15.977	17.430	15.39	-	-	80	31.839	31.089	32.565	118	46.957	46.207	47.690				
43	17.124	16.374	17.829	15.80	-	-	81	32.237	31.487	32.963	119	47.354	46.604	48.088				
44	17.522	16.772	18.228	16.19	-	-	82	32.635	31.885	33.361	120	47.752	47.002	48.485				
45	17.920	17.170	18.626	16.59	-	-	83	33.033	32.283	33.759	Larger sizes available.							

Hub length thru bore, inches

Sprocket Type	Number of Teeth	Chain Width, Number of Strands					
		1	2	3	4	5	6
B	8 to 13	1.50	2.88	4.25	5.75	7.13	8.50
	14 to 18	1.75	3.13	4.50	6.00	7.38	8.75
	19 to 38	2.00	3.38	4.75	6.25	7.63	9.00
	39 to 53	2.25	3.63	5.00	6.50	7.88	9.25
	54 to 68	2.50	3.88	5.25	6.75	8.13	9.50
	69 to 88	2.75	4.13	5.50	7.00	8.38	9.75
	89 to 120	3.00	4.38	5.75	7.25	8.63	10.00
C	15 to 26	3.00	4.25	5.25	6.25	7.25	8.25
	27 to 40	3.25	4.25	5.25	6.25	7.25	8.25
	41 to 60	3.50	4.50	5.25	6.25	7.25	8.25
	61 to 72	3.75	4.75	5.50	6.50	7.50	8.50
	73 to 80	4.00	5.00	5.75	6.75	7.75	8.75
	81 to 100	4.25	5.25	6.00	7.00	8.00	9.00
	101 to 120	4.50	5.50	6.25	7.25	8.25	9.25

Tooth dimensions, inches

Dimension	Chain Width, Number of Strands					
	1	2	3	4	5	6
T	.692	.669	.669	.633	.633	.633
L	-	2.077	3.485	4.857	6.265	7.673
K	-	1.408	1.408	1.408	1.408	1.408
Machined sprockets +.000", -.014"						
Hot rolled steel plate sprockets or unfinished forgings +.000", -.046"						
Tolerances for T and L						

Recommended standard bore tolerances, keyseat dimensions, eccentricity tolerances, and similar data, page G-2.
 Δ Non-functional dimension that may vary with the type of cutter used.
 ▲ Based on maximum hub diameter.

Drive Engineering

No. 120 chain 1.500" pitch

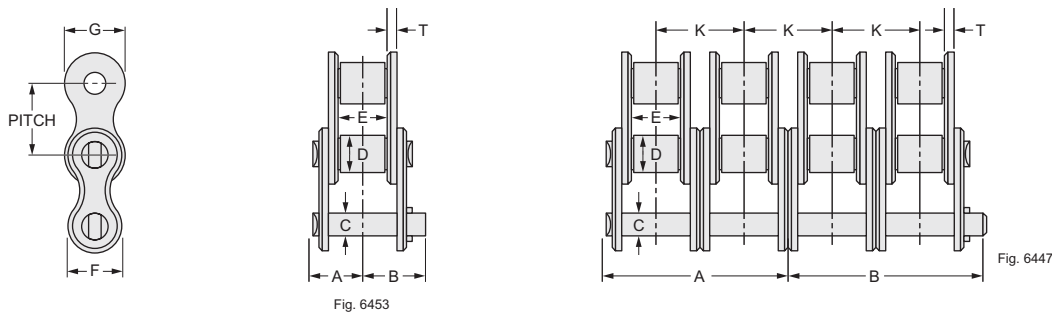

Specifications and dimensions

Chain Number	Chain Width, Number of Strands	Average ultimate strength, pounds	Joint bearing area, sq. in.	Weight per foot, pounds	Dimensions, inches								
					A	B	C	D	E	F	G	K	T
120	Single	36,500	.606	3.72	.96	1.13	.438	.875	1.00	1.13	1.38	1.789	.19
120-2	Double	73,000	1.212	7.38	1.84	2.02	.438	.875	1.00	1.13	1.38	1.789	.19
120-3	Triple	109,500	1.818	11.0	2.74	2.91	.438	.875	1.00	1.13	1.38	1.789	.19
120-4	Quadruple	146,000	2.424	14.7	3.63	3.81	.438	.875	1.00	1.13	1.38	1.789	.19
120-5	Quintuple	182,500	3.030	18.4	4.52	4.70	.438	.875	1.00	1.13	1.38	1.789	.19
120-6	Sextuple	219,000	3.636	22.0	5.42	5.59	.438	.875	1.00	1.13	1.38	1.789	.19

Available in riveted and cottered construction.

Ratings

Number of teeth, in small sprocket	Maximum bore inches	Horsepower for single strand chain ▲																			
		RPM of small sprocket																			
		10	25	50	100	200	300	400	500	600	700	800	900	1000	1100	1200	1300	1400	1600	1800	2000
11	2.438	1.37	3.12	5.83	10.9	20.3	29.2	37.9	46.3	54.6	63.3	37.9	31.8	27.1	23.5	20.6	18.3	16.4	13.4	11.2	9.59
12	2.750	1.50	3.43	6.40	11.9	22.3	32.1	41.6	50.9	59.9	52.8	43.2	36.2	30.9	26.8	23.5	20.9	18.7	15.3	12.8	10.9
13	3.188	1.64	3.74	6.98	13.0	24.3	35.0	45.4	55.5	65.3	59.5	48.7	40.8	34.9	30.2	26.5	23.5	21.0	17.2	14.4	12.3
14	3.625	1.78	4.05	7.56	14.1	26.3	37.9	49.1	60.1	70.8	66.5	54.4	45.6	39.0	33.8	29.6	26.3	23.5	19.2	16.1	8.94
15	4.000	1.91	4.37	8.15	15.2	28.4	40.9	53.0	64.7	76.3	73.8	60.4	50.6	43.2	37.4	32.9	29.1	26.1	21.3	17.9	0
16	4.438	2.05	4.68	8.74	16.3	30.4	43.8	56.8	69.4	81.8	81.3	66.5	55.7	47.6	41.2	36.2	32.1	28.7	23.5	19.7	0
17	4.688	2.19	5.00	9.33	17.4	32.5	46.8	60.6	74.1	87.3	89.0	72.8	61.0	52.1	45.2	39.6	35.2	31.5	25.8	21.6	0
18	5.188	2.33	5.32	9.92	18.5	34.6	49.8	64.5	78.8	92.9	97.0	79.4	66.5	56.8	49.2	43.2	38.3	34.3	28.1	23.5	0
19	5.563	2.47	5.64	10.5	19.6	36.6	52.8	68.4	83.6	98.5	105	86.1	72.1	61.6	53.4	46.8	41.5	37.2	30.4	25.5	0
20	5.938	2.61	5.96	11.1	20.7	38.7	55.8	72.2	88.3	104	114	92.9	77.9	66.5	57.6	50.6	44.9	40.1	32.9	27.5	0
21	6.375	2.75	6.28	11.7	21.9	40.8	58.8	76.2	93.1	110	122	100	83.8	71.6	62.0	54.4	48.3	43.2	35.4	29.6	0
22	6.500	2.90	6.60	12.3	23.0	42.9	61.8	80.1	97.9	115	131	107	89.9	76.7	66.5	58.4	51.8	46.3	37.9	16.6	0
23	6.688	3.04	6.93	12.9	24.1	45.0	64.9	84.0	103	121	139	115	96.1	82.0	71.1	62.4	55.3	49.5	40.5	0	-
24	7.000	3.18	7.25	13.5	25.3	47.1	67.9	88.0	108	127	146	122	102	87.4	75.8	66.5	59.0	52.8	43.2	0	-
25	7.250	3.32	7.58	14.1	26.4	49.3	71.0	91.9	112	132	152	130	109	92.9	80.6	70.7	62.7	56.1	45.9	0	-
28	8.375	3.76	8.57	16.0	29.8	55.7	80.2	104	127	150	172	154	129	110	95.5	83.8	74.3	66.5	54.4	0	-
30	9.250	4.05	9.23	17.2	32.1	60.0	86.4	112	137	161	185	171	143	122	106	92.9	82.4	73.8	42.4	0	-
32	10.000	4.34	9.90	18.5	34.5	64.3	92.6	120	147	173	199	188	158	135	117	102	90.8	81.3	0	-	-
35	-	4.78	10.9	20.3	38.0	70.9	102	132	162	190	219	215	180	154	133	117	104	92.9	0	-	-
40	-	5.52	12.6	23.5	43.9	81.8	118	153	187	220	253	263	220	188	163	143	127	59.5	0	-	-
Lubrication type ■		A			B				C												

The dotted line indicates the point at which pin and bushing galling is likely to begin. When the desired selection falls within the shaded area, consult Rexnord for guidance.

▲ Ratings are based on a service factor of 1. For a complete list of service factors, refer to Table 1, page C-7. The ratings listed above apply directly to lubricated, single strand, standard and heavy series roller chains. For multiple strand chains, apply the factors shown in the table at right. To select chains that vary in design or material from standard roller chain, use the factors in Table 3, page C-7.

■ Type A: Manual or drip (Maximum chain speed 130 FPM)
 Type B: Bath or disc (Maximum chain speed 1200 FPM)
 Type C: Forced (pump)

Multiple strand factors

Number of strands	Multiple strand factor
2	1.7
3	2.5
4	3.3
5	4.1
6	5.0
7 or more	Consult Rexnord

No. 120 sprockets 1.500" pitch

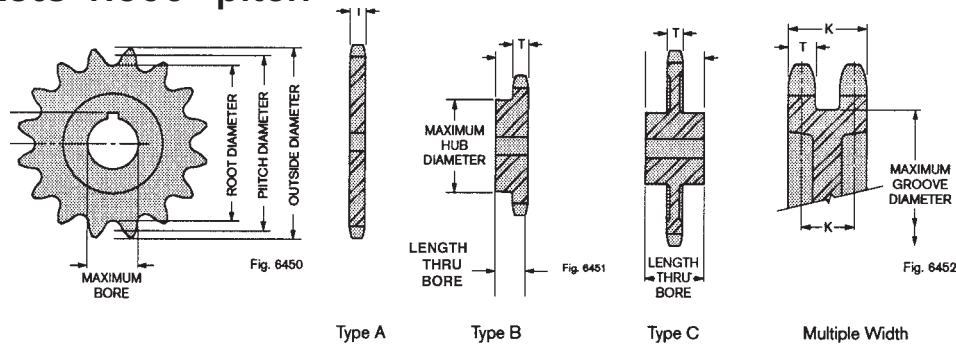

Dimensions

Number of teeth	Pitch diameter, inches	Root diameter, inches	Outside diameter, inches Δ	Maximum hub and groove diameter, inches	Maximum bore with standard keyseat, inches ▲	S max., inches	Type A				Type B				Type C				Multiple Width			
							Number of teeth	Pitch diameter, inches	Root diameter, inches	Outside diameter, inches Δ	Number of teeth	Pitch diameter, inches	Root diameter, inches	Outside diameter, inches Δ	Number of teeth	Pitch diameter, inches	Root diameter, inches	Outside diameter, inches Δ	Number of teeth	Pitch diameter, inches	Root diameter, inches	Outside diameter, inches Δ
8	3.920	3.045	4.521	2.08	1.313	.813	39	18.641	17.766	19.481	70	33.434	32.559	34.301								
9	4.386	3.511	5.021	2.58	1.625	1.000	40	19.118	18.243	19.959	71	33.911	33.036	34.778								
10	4.854	3.979	5.517	3.08	2.063	1.281	41	19.595	18.720	20.438	72	34.388	33.513	35.256								
11	5.324	4.449	6.009	3.58	2.438	1.531	42	20.072	19.197	20.916	73	34.866	33.991	35.733								
12	5.796	4.921	6.498	4.06	2.750	1.688	43	20.549	19.674	21.395	74	35.343	34.468	36.212								
13	6.268	5.393	6.986	4.55	3.188	1.969	44	21.026	20.151	21.873	75	35.820	34.945	36.689								
14	6.741	5.866	7.473	5.03	3.625	2.250	45	21.503	20.628	22.352	76	36.298	35.423	37.167								
15	7.215	6.340	7.958	5.52	4.000	2.500	46	21.980	21.105	22.829	77	36.766	35.900	37.644								
16	7.689	6.814	8.441	6.00	4.438	2.719	47	22.458	21.583	23.307	78	37.252	36.377	38.123								
17	8.163	7.288	8.925	6.48	4.688	2.844	48	22.935	22.060	23.786	79	37.730	36.855	38.600								
18	8.638	7.763	9.407	6.97	5.188	3.219	49	23.412	22.537	24.264	80	38.207	37.332	39.078								
19	9.113	8.238	9.890	7.45	5.563	3.406	50	23.889	23.014	24.743	81	38.684	37.809	39.555								
20	9.589	8.714	10.371	7.94	5.938	3.719	51	24.366	23.491	25.220	82	39.162	38.287	40.034								
21	10.064	9.189	10.853	8.42	6.375	3.938	52	24.843	23.968	25.698	83	39.639	38.764	40.511								
22	10.540	9.665	11.333	8.89	6.500	4.000	53	25.320	24.445	26.177	84	40.116	39.241	40.989								
23	11.016	10.141	11.813	9.38	6.688	4.094	54	25.798	24.923	26.654	85	40.594	39.719	41.466								
24	11.492	10.617	12.294	9.86	7.000	4.250	55	26.275	25.400	27.132	86	41.071	40.196	41.943								
25	11.968	11.093	12.774	10.34	7.250	4.375	56	26.752	25.877	27.609	87	41.548	40.673	42.422								
26	12.444	11.569	13.254	10.81	7.625	4.688	57	27.229	26.354	28.088	88	42.026	41.151	42.899								
27	12.921	12.046	13.734	11.30	8.000	4.875	58	27.707	26.832	28.566	89	42.503	41.628	43.377								
28	13.397	12.522	14.212	11.78	8.375	4.938	59	28.184	27.309	29.045	90	42.981	42.106	43.854								
29	13.874	12.999	14.693	12.25	8.750	5.250	60	28.661	27.786	29.522	91	43.458	42.583	44.331								
30	14.350	13.475	15.171	12.73	9.250	5.500	61	29.138	28.263	30.000	92	43.935	43.060	44.810								
31	14.827	13.952	15.651	13.22	9.750	5.750	62	29.616	28.741	30.477	93	44.412	43.537	45.287								
32	15.303	14.428	16.130	13.69	10.000	6.000	63	30.093	29.218	30.956	94	44.889	44.014	45.765								
33	15.780	14.905	16.608	14.17	-	-	64	30.570	29.695	31.433	95	45.367	44.492	46.242								
34	16.257	15.382	17.088	14.66	-	-	65	31.047	30.172	31.911	96	45.844	44.969	46.719								
35	16.734	15.859	17.567	15.13	-	-	66	31.525	30.650	32.390	97	46.321	45.446	47.198								
36	17.211	16.336	18.045	15.61	-	-	67	32.002	31.127	32.867	98	46.799	45.924	47.657								
37	17.687	16.812	18.524	16.09	-	-	68	32.479	31.604	33.345	99	47.277	46.402	48.153								
38	18.164	17.289	19.002	16.56	-	-	69	32.957	32.082	33.822	100	47.754	46.879	48.630								

Larger sizes available.

Hub length thru bore, inches

Sprocket Type	Number of Teeth	Chain Width, Number of Strands					
		1	2	3	4	5	6
B	8 to 12	2.00	3.75	5.50	7.38	9.13	10.88
	13 to 16	2.25	4.00	5.75	7.63	9.38	11.13
	17 to 34	2.50	4.13	5.88	7.75	9.50	11.25
	35 to 52	2.75	4.38	6.13	8.00	9.75	11.50
	53 to 73	3.00	4.63	6.38	8.25	10.00	11.75
	74 to 100	3.25	4.88	6.63	8.50	10.25	12.00
C	14 to 21	3.50	4.75	5.25	6.25
	22 to 27	3.50	4.75	5.50	6.50
	28 to 36	3.50	4.75	5.75	6.75
	37 to 46	3.75	4.75	6.00	7.00	8.00	...
	47 to 60	4.00	5.00	6.25	7.25	8.25	9.25
	61 to 72	4.25	5.25	6.50	7.50	8.50	9.50
	73 to 80	4.50	5.50	6.75	7.75	8.75	9.75
	81 to 94	5.00	6.00	7.25	8.25	9.25	10.25
	95 to 100	5.50	6.50	7.75	8.75	9.75	10.75

Tooth dimensions, inches

Dimension	Chain Width, Number of Strands					
	1	2	3	4	5	6
T	.924	.894	.894	.848	.848	.848
L	-	2.683	4.472	6.215	8.004	9.793
K	-	1.789	1.789	1.789	1.789	1.789
Machined sprockets +.000", -.016"						
Tolerances for T and L Hot rolled steel plate sprockets or unfinished forgings +.000", -.057"						

Recommended standard bore tolerances, keyseat dimensions, eccentricity tolerances, and similar data, page G-2.

Δ Non-functional dimension that may vary with the type of cutter used.

▲ Based on maximum hub diameter.

Drive Engineering

No. 140 chain 1.750" pitch

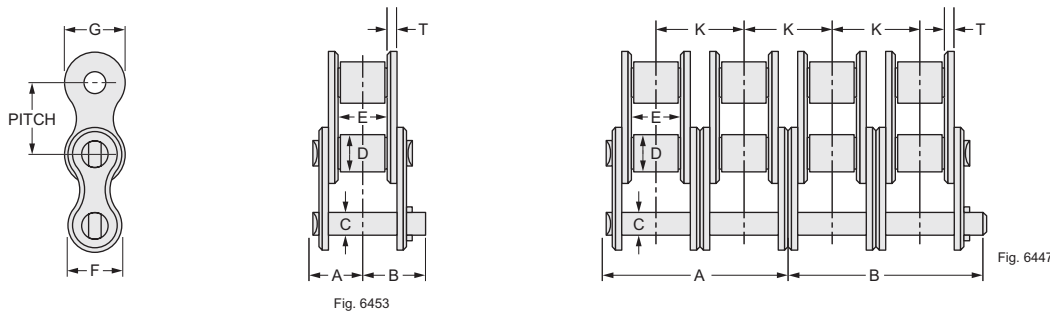

Specifications and dimensions

Chain Number	Chain Width, Number of Strands	Average ultimate strength, pounds	Joint bearing area, sq. in.	Weight per foot, pounds	Dimensions, inches								
					A	B	C	D	E	F	G	K	T
140	Single	48,500	.726	4.69	1.02	1.21	.500	1.000	1.00	1.31	1.56	1.924	.22
140-2	Double	97,000	1.452	9.25	1.98	2.17	.500	1.000	1.00	1.31	1.56	1.924	.22
140-3	Triple	145,500	2.178	13.8	2.94	3.13	.500	1.000	1.00	1.31	1.56	1.924	.22
140-4	Quadruple	194,000	2.904	18.4	3.90	4.09	.500	1.000	1.00	1.31	1.56	1.924	.22
140-5	Quintuple	242,500	3.630	22.9	4.86	5.05	.500	1.000	1.00	1.31	1.56	1.924	.22
140-6	Sextuple	291,000	4.356	27.4	5.82	6.01	.500	1.000	1.00	1.31	1.56	1.924	.22

Available in riveted and cottered construction.

Ratings

Number of teeth, in small sprocket	Maximum bore inches	Horsepower for single strand chain ▲																			
		RPM of small sprocket																			
		10	25	50	100	150	200	250	300	350	400	450	500	550	600	700	800	1000	1200	1400	1600
11	2.750	2.12	4.83	9.02	16.8	24.2	31.4	38.4	45.2	52.0	58.6	65.2	71.6	75.2	66.0	52.4	42.9	30.7	23.3	18.5	15.2
12	3.125	2.33	5.31	9.91	18.5	26.6	34.5	42.2	49.7	57.1	64.4	71.6	78.7	85.7	75.2	59.7	48.9	35.0	26.6	21.1	17.3
13	3.625	2.54	5.79	10.8	20.2	29.0	37.6	46.0	54.2	62.2	70.2	78.0	85.8	93.5	84.8	67.3	55.1	39.4	30.0	23.8	19.5
14	4.063	2.75	6.27	11.7	21.8	31.5	40.8	49.8	58.7	67.4	76.0	84.5	93.0	101	94.8	75.2	61.6	44.1	33.5	26.6	21.8
15	4.688	2.96	6.76	12.6	23.5	33.9	43.9	53.7	63.2	72.7	81.9	91.1	100	109	105	83.4	68.3	48.9	37.2	29.5	0
16	5.063	3.18	7.24	13.5	25.2	36.3	47.1	57.5	67.8	77.9	87.8	97.7	107	117	116	91.9	75.2	53.8	41.0	32.5	0
17	5.625	3.39	7.73	14.4	26.9	38.8	50.3	61.4	72.4	83.2	93.8	104	115	125	127	101	82.4	59.0	44.9	35.6	0
18	5.938	3.61	8.23	15.4	28.6	41.3	53.5	65.3	77.0	88.5	99.8	111	122	133	138	110	89.8	64.2	48.9	38.8	0
19	6.250	3.82	8.72	16.3	30.4	43.7	56.7	69.3	81.6	93.8	106	118	129	141	150	119	97.4	69.7	53.0	42.1	0
20	6.688	4.04	9.22	17.2	32.1	46.2	59.9	73.2	86.3	99.1	112	124	137	149	161	128	105	75.2	57.2	45.4	0
21	7.125	4.26	9.72	18.1	33.8	48.7	63.1	77.2	91.0	104	118	131	144	157	170	138	113	80.9	61.6	48.9	0
22	7.438	4.48	10.2	19.1	35.6	51.3	66.4	81.2	95.6	110	124	138	151	165	178	148	121	86.8	66.0	52.4	0
23	8.125	4.70	10.7	20.0	37.3	53.8	69.7	85.2	100	115	130	145	159	173	187	158	130	92.8	70.6	56.0	0
24	8.625	4.92	11.2	20.9	39.1	56.3	72.9	89.2	105	121	136	151	166	181	196	169	138	98.9	75.2	59.7	0
25	8.813	5.14	11.7	21.9	40.8	58.8	76.2	93.2	110	126	142	158	174	189	205	180	147	105	80.0	63.5	0
28	10.000	5.81	13.3	24.7	46.2	66.5	86.2	105	124	143	161	179	197	214	232	213	174	125	94.8	0	-
30	-	6.26	14.3	26.7	49.7	71.6	92.8	113	134	154	173	193	212	231	249	236	193	138	105	0	-
32	-	6.71	15.3	28.6	53.3	76.8	99.5	122	143	165	186	206	227	247	267	260	213	152	116	0	-
35	-	7.40	16.9	31.5	58.7	84.6	110	134	158	181	205	227	250	272	295	297	243	174	130	0	-
40	-	8.54	19.5	36.4	67.9	97.7	127	155	182	210	236	263	289	315	340	363	297	213	0	-	-
Lubrication type ■		A			B						C										

The dotted line indicates the point at which pin and bushing galling is likely to begin. When the desired selection falls within the shaded area, consult Rexnord for guidance.

▲ Ratings are based on a service factor of 1. For a complete list of service factors, refer to Table 1, page C-7. The ratings listed above apply directly to lubricated, single strand, standard and heavy series roller chains. For multiple strand chains, apply the factors shown in the table at right. To select chains that vary in design or material from standard roller chain, use the factors in Table 3, page C-7.

■ Type A: Manual or drip (Maximum chain speed 130 FPM)
 Type B: Bath or disc (Maximum chain speed 1200 FPM)
 Type C: Forced (pump)

Multiple strand factors

Number of strands	Multiple strand factor
2	1.7
3	2.5
4	3.3
5	4.1
6	5.0
7 or more	Consult Rexnord

No. 140 sprockets 1.750" pitch

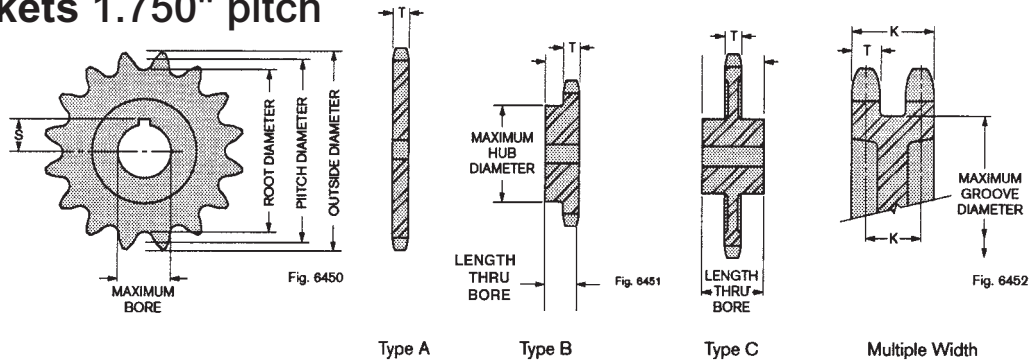

Dimensions

Number of teeth	Pitch diameter, inches	Root diameter, inches	Outside diameter, inches Δ	Maximum hub and groove diameter, inches	Maximum bore with standard keyseat, inches \blacktriangle	S max., inches	Type A				Type B				Type C				Multiple Width			
							Number of teeth	Pitch diameter, inches	Root diameter, inches	Outside diameter, inches Δ	Number of teeth	Pitch diameter, inches	Root diameter, inches	Outside diameter, inches Δ	Number of teeth	Pitch diameter, inches	Root diameter, inches	Outside diameter, inches Δ	Number of teeth	Pitch diameter, inches	Root diameter, inches	Outside diameter, inches Δ
8	3.920	3.045	4.521	2.08	1.313	.813	39	18.641	17.766	19.481	70	33.434	32.559	34.301								
9	4.386	3.511	5.021	2.58	1.625	1.000	40	19.118	18.243	19.959	71	33.911	33.036	34.778								
10	4.854	3.979	5.517	3.08	2.063	1.281	41	19.595	18.720	20.438	72	34.388	33.513	35.256								
11	5.324	4.449	6.009	3.58	2.438	1.531	42	20.072	19.197	20.916	73	34.866	33.991	35.733								
12	5.796	4.921	6.498	4.06	2.750	1.688	43	20.549	19.674	21.395	74	35.343	34.468	36.212								
13	6.268	5.393	6.986	4.55	3.188	1.969	44	21.026	20.151	21.873	75	35.820	34.945	36.689								
14	6.741	5.866	7.473	5.03	3.625	2.250	45	21.503	20.628	22.352	76	36.298	35.423	37.167								
15	7.215	6.340	7.958	5.52	4.000	2.500	46	21.980	21.105	22.829	77	36.766	35.900	37.644								
16	7.689	6.814	8.441	6.00	4.438	2.719	47	22.458	21.583	23.307	78	37.252	36.377	38.123								
17	8.163	7.288	8.925	6.48	4.688	2.844	48	22.935	22.060	23.786	79	37.730	36.855	38.600								
18	8.638	7.763	9.407	6.97	5.188	3.219	49	23.412	22.537	24.264	80	38.207	37.332	39.078								
19	9.113	8.238	9.890	7.45	5.563	3.406	50	23.889	23.014	24.743	81	38.684	37.809	39.555								
20	9.589	8.714	10.371	7.94	5.938	3.719	51	24.366	23.491	25.220	82	39.162	38.287	40.034								
21	10.064	9.189	10.853	8.42	6.375	3.938	52	24.843	23.968	25.698	83	39.639	38.764	40.511								
22	10.540	9.665	11.333	8.89	6.500	4.000	53	25.320	24.445	26.177	84	40.116	39.241	40.989								
23	11.016	10.141	11.813	9.38	6.688	4.094	54	25.798	24.923	26.654	85	40.594	39.719	41.466								
24	11.492	10.617	12.294	9.86	7.000	4.250	55	26.275	25.400	27.132	86	41.071	40.196	41.943								
25	11.968	11.093	12.774	10.34	7.250	4.375	56	26.752	25.877	27.609	87	41.548	40.673	42.422								
26	12.444	11.569	13.254	10.81	7.625	4.688	57	27.229	26.354	28.088	88	42.026	41.151	42.899								
27	12.921	12.046	13.734	11.30	8.000	4.875	58	27.707	26.832	28.566	89	42.503	41.628	43.377								
28	13.397	12.522	14.212	11.78	8.375	4.938	59	28.184	27.309	29.045	90	42.981	42.106	43.854								
29	13.874	12.999	14.693	12.25	8.750	5.250	60	28.661	27.786	29.522	91	43.458	42.583	44.331								
30	14.350	13.475	15.171	12.73	9.250	5.500	61	29.138	28.263	30.000	92	43.935	43.060	44.810								
31	14.827	13.952	15.651	13.22	9.750	5.750	62	29.616	28.741	30.477	93	44.412	43.537	45.287								
32	15.303	14.428	16.130	13.69	10.000	6.000	63	30.093	29.218	30.956	94	44.889	44.014	45.765								
33	15.780	14.905	16.608	14.17	-	-	64	30.570	29.695	31.433	95	45.367	44.492	46.242								
34	16.257	15.382	17.088	14.66	-	-	65	31.047	30.172	31.911	96	45.844	44.969	46.719								
35	16.734	15.859	17.567	15.13	-	-	66	31.525	30.650	32.390	97	46.321	45.446	47.198								
36	17.211	16.336	18.045	15.61	-	-	67	32.002	31.127	32.867	98	46.799	45.924	47.657								
37	17.687	16.812	18.524	16.09	-	-	68	32.479	31.604	33.345	99	47.277	46.402	48.153								
38	18.164	17.289	19.002	16.56	-	-	69	32.957	32.082	33.822	100	47.754	46.879	48.630								

Larger sizes available.

Hub length thru bore, inches

Sprocket Type	Number of Teeth	Chain Width, Number of Strands					
		1	2	3	4	5	6
B	8 to 12	2.00	3.75	5.50	7.38	9.13	10.88
	13 to 16	2.25	4.00	5.75	7.63	9.38	11.13
	17 to 34	2.50	4.13	5.88	7.75	9.50	11.25
	35 to 52	2.75	4.38	6.13	8.00	9.75	11.50
	53 to 73	3.00	4.63	6.38	8.25	10.00	11.75
	74 to 100	3.25	4.88	6.63	8.50	10.25	12.00
	14 to 21	3.50	4.75	5.25	6.25	-	-
22 to 27	3.50	4.75	5.50	6.50	-	-	
28 to 36	3.50	4.75	5.75	6.75	-	-	
37 to 46	3.75	4.75	6.00	7.00	8.00	-	
C	47 to 60	4.00	5.00	6.25	7.25	8.25	9.25
	61 to 72	4.25	5.25	6.50	7.50	8.50	9.50
	73 to 80	4.50	5.50	6.75	7.75	8.75	9.75
	81 to 94	5.00	6.00	7.25	8.25	9.25	10.25
	95 to 100	5.50	6.50	7.75	8.75	9.75	10.75

Tooth dimensions, inches

Dimension	Chain Width, Number of Strands					
	1	2	3	4	5	6
T	.924	.894	.894	.848	.848	.848
L	-	2.683	4.472	6.215	8.004	9.793
K	-	1.789	1.789	1.789	1.789	1.789
Machined sprockets +.000", -.016"						
Tolerances for T and L Hot rolled steel plate sprockets or unfinished forgings +.000", -.057"						

Recommended standard bore tolerances, keyseat dimensions, eccentricity tolerances, and similar data, page G-2.

Δ Non-functional dimension that may vary with the type of cutter used.

\blacktriangle Based on maximum hub diameter.

Drive Engineering

No. 160 chain 2.000" pitch

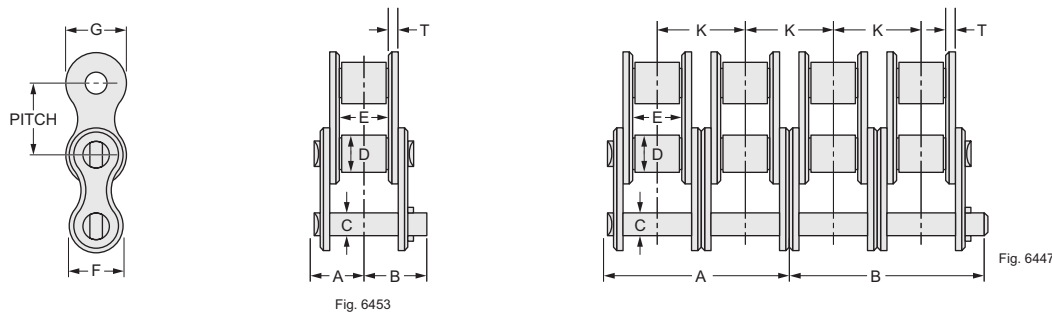

Specifications and dimensions

Chain Number	Chain Width, Number of Strands	Average ultimate strength, pounds	Joint bearing area, sq. in.	Weight per foot, pounds	Dimensions, inches								
					A	B	C	D	E	F	G	K	T
160	Single	68,000	.991	6.12	1.23	1.41	.563	1.125	1.25	1.56	1.81	2.305	.25
160-2	Double	136,000	1.982	12.5	2.38	2.56	.563	1.125	1.25	1.56	1.81	2.305	.25
160-3	Triple	204,000	2.973	18.6	3.52	3.71	.563	1.125	1.25	1.56	1.81	2.305	.25
160-4	Quadruple	272,000	3.964	24.8	4.67	4.86	.563	1.125	1.25	1.56	1.81	2.305	.25
160-5	Quintuple	340,000	4.955	31.9	5.82	6.00	.563	1.125	1.25	1.56	1.81	2.305	.25
160-6	Sextuple	408,000	5.946	38.3	6.97	7.15	.563	1.125	1.25	1.56	1.81	2.305	.25

Available in riveted and cottered construction.

Ratings

Number of teeth, in small sprocket	Maximum bore inches	Horsepower for single strand chain ▲																				
		RPM of small sprocket																				
		10	25	50	100	150	200	250	300	350	400	450	500	550	600	700	800	900	1000	1100	1200	
11	3.250	3.07	7.01	13.1	24.4	35.2	45.6	55.7	65.6	75.4	85.0	94.5	96.6	83.7	73.5	58.3	47.7	40.0	34.1	29.6	26.0	
12	3.500	3.38	7.70	14.4	26.8	38.6	50.1	61.2	72.1	82.8	93.4	104	110	95.4	83.7	66.4	54.4	45.6	38.9	33.7	29.6	
13	4.000	3.68	8.40	15.7	29.2	42.1	54.6	66.7	78.6	90.3	102	113	124	108	94.4	74.9	61.3	51.4	43.9	38.0	33.4	
14	4.563	3.99	9.10	17.0	31.7	45.6	59.1	72.3	85.2	97.8	110	123	135	120	105	83.7	68.5	57.4	49.0	42.5	37.3	
15	5.000	4.30	9.80	18.3	34.1	49.2	63.7	77.9	91.7	105	119	132	145	133	117	92.8	76.0	63.7	54.4	47.1	41.4	
16	5.625	4.61	10.5	19.6	36.6	52.7	68.3	83.5	98.4	113	127	142	156	147	129	102	83.7	70.2	59.9	51.9	45.6	
17	6.313	4.92	11.2	20.9	39.1	56.3	72.9	89.1	105	121	136	151	166	161	141	112	91.7	76.8	65.6	56.9	49.9	
18	6.500	5.23	11.9	22.3	41.6	59.9	77.6	94.8	112	128	145	161	177	175	154	122	99.9	83.7	71.5	62.0	54.4	
19	7.063	5.55	12.7	23.6	44.1	63.5	82.2	101	118	136	153	171	188	190	167	132	108	90.8	77.5	67.2	59.0	
20	7.250	5.86	13.4	25.0	46.6	67.1	86.9	106	125	144	162	180	198	205	180	143	117	98.1	83.7	72.6	63.7	
21	7.750	6.18	14.1	26.3	49.1	70.7	91.6	112	132	152	171	190	209	221	194	154	126	105	90.1	78.1	68.5	
22	8.125	6.50	14.8	27.7	51.6	74.4	96.3	118	139	159	180	200	220	237	208	165	135	113	96.6	83.7	0	
23	8.750	6.82	15.6	29.0	54.2	78.0	101	124	146	167	189	210	231	251	222	176	144	121	103	89.5	0	
24	9.625	7.14	16.3	30.4	56.7	81.7	106	129	152	175	197	220	241	263	237	188	154	129	110	95.4	0	
25	-	7.46	17.0	31.8	59.3	85.4	111	135	159	183	206	229	252	275	252	200	164	137	117	101	0	
28	-	8.43	19.2	35.9	67.0	96.5	125	153	180	207	233	259	285	311	298	237	194	162	139	120	0	
30	-	9.08	20.7	38.7	72.2	104	135	165	194	223	251	279	307	336	331	263	215	180	154	0	-	
32	-	9.74	22.2	41.5	77.4	111	144	176	208	239	269	300	329	359	365	289	237	198	169	0	-	
35	-	10.7	24.5	45.7	85.2	123	159	194	229	263	297	330	363	395	417	331	271	227	180	0	-	
40	-	12.4	28.3	52.8	98.5	142	184	225	265	304	343	381	419	457	494	404	331	257	0	-	-	
Lubrication type ■		A	B					C														

The dotted line indicates the point at which pin and bushing galling is likely to begin. When the desired selection falls within the shaded area, consult Rexnord for guidance.

▲ Ratings are based on a service factor of 1. For a complete list of service factors, refer to Table 1, page C-7. The ratings listed above apply directly to lubricated, single strand, standard and heavy series roller chains. For multiple strand chains, apply the factors shown in the table at right. To select chains that vary in design or material from standard roller chain, use the factors in Table 3, page C-7.

■ Type A: Manual or drip (Maximum chain speed 130 FPM)
 Type B: Bath or disc (Maximum chain speed 1200 FPM)
 Type C: Forced (pump)

Multiple strand factors

Number of strands	Multiple strand factor
2	1.7
3	2.5
4	3.3
5	4.1
6	5.0
7 or more	Consult Rexnord

No. 160 sprockets 2.000" pitch

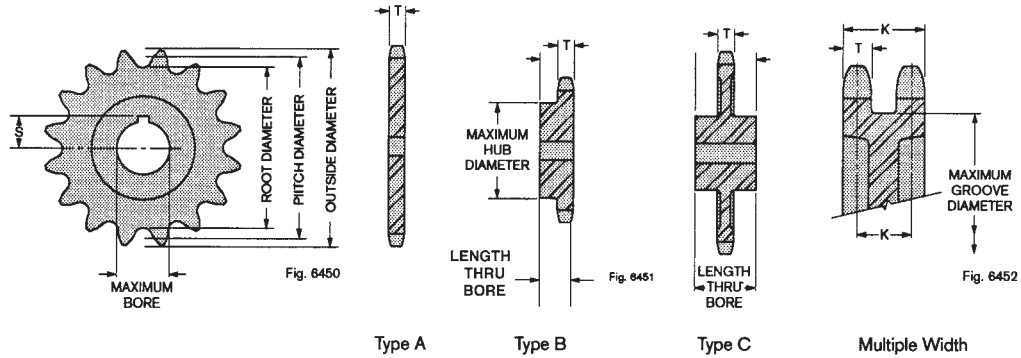

Dimensions

Number of teeth	Pitch diameter, inches	Root diameter, inches	Outside diameter, inches Δ	Maximum hub and groove diameter, inches	Maximum bore with standard keyseat, inches ▲	S max., inches	Number of teeth	Pitch diameter, inches	Root diameter, inches	Outside diameter, inches Δ	Number of teeth	Pitch diameter, inches	Root diameter, inches	Outside diameter, inches Δ
8	5.226	4.101	6.028	2.80	1.750	1.063	39	24.855	23.730	25.974	70	44.578	43.453	45.734
9	5.848	4.723	6.694	3.45	2.250	1.375	40	25.491	24.366	26.612	71	45.215	44.090	46.370
10	6.472	5.347	7.356	4.13	2.750	1.688	41	26.127	25.002	27.250	72	45.851	44.726	47.008
11	7.099	5.974	8.012	4.78	3.250	2.000	42	26.763	25.638	27.888	73	46.488	45.363	47.644
12	7.727	6.602	8.664	5.42	3.500	2.188	43	27.399	26.274	28.526	74	47.124	45.999	48.282
13	8.357	7.232	9.314	6.08	4.000	2.500	44	28.035	26.910	29.164	75	47.760	46.635	48.918
14	8.988	7.863	9.964	6.72	4.563	2.781	45	28.671	27.546	29.802	76	48.397	47.272	49.556
15	9.620	8.495	10.610	7.38	5.000	3.125	46	29.307	28.182	30.438	77	49.033	47.908	50.192
16	10.252	9.127	11.254	8.02	5.625	3.438	47	29.943	28.818	31.076	78	49.670	48.545	50.830
17	10.885	9.760	11.900	8.66	6.313	3.906	48	30.580	29.455	31.714	79	50.306	49.181	51.466
18	11.518	10.393	12.542	9.31	6.500	4.000	49	31.216	30.091	32.352	80	50.943	49.818	52.104
19	12.151	11.026	13.186	9.95	7.063	4.281	50	31.852	30.727	32.990	81	51.579	50.454	52.740
20	12.785	11.660	13.828	10.59	7.250	4.375	51	32.488	31.363	33.626	82	52.216	51.091	53.378
21	13.419	12.294	14.470	11.23	7.750	4.750	52	33.124	31.999	34.264	83	52.852	51.727	54.014
22	14.053	12.928	15.110	11.88	8.188	4.938	53	33.761	32.636	34.902	84	53.489	52.364	54.652
23	14.688	13.563	15.750	12.52	8.750	5.250	54	34.397	33.272	35.538	85	54.125	53.000	55.288
24	15.323	14.198	16.392	13.16	9.625	5.688	55	35.033	33.908	36.176	86	54.761	53.637	55.924
25	15.958	14.833	17.032	13.80	-	-	56	35.669	34.544	36.812	87	55.398	54.273	56.562
26	16.593	15.468	17.672	14.44	-	-	57	36.306	35.181	37.450	88	56.034	54.909	57.198
27	17.228	16.103	18.312	15.08	-	-	58	36.942	35.817	38.088	89	56.671	55.546	57.836
28	17.863	16.738	18.950	15.72	-	-	59	37.578	36.453	38.726	90	57.307	56.182	58.472
29	18.498	17.373	19.590	16.36	-	-	60	38.215	37.090	39.362	91	57.944	56.819	59.110
30	19.134	18.009	20.228	17.00	-	-	61	38.851	37.726	40.000	92	58.580	57.455	59.750
31	19.769	18.644	20.868	17.63	-	-	62	39.487	38.362	40.636	93	59.216	58.091	60.380
32	20.405	19.280	21.506	18.27	-	-	63	40.124	38.999	41.274	94	59.853	58.728	61.020
33	21.040	19.915	22.144	18.91	-	-	64	40.760	39.635	41.910	95	60.489	59.364	61.660
34	21.676	20.551	22.784	19.55	-	-	65	41.396	40.271	42.548	96	61.126	60.001	62.290
35	22.312	21.187	23.422	20.19	-	-	66	42.033	40.908	43.186	97	61.762	60.637	62.930
36	22.947	21.822	24.060	20.83	-	-	67	42.669	41.544	43.822	98	62.399	61.274	63.570
37	23.583	22.458	24.698	21.47	-	-	68	43.306	42.181	44.460	99	63.035	61.910	64.200
38	24.219	23.094	25.336	22.09	-	-	69	43.942	42.817	45.096	100	63.672	62.547	64.840

Larger sizes available.

Hub length thru bore, inches

Sprocket Type	Number of Teeth	Chain Width, Number of Strands					
		1	2	3	4	5	6
B	8 to 12	2.25	4.50	6.88	9.13	11.38	13.63
	13 to 15	2.50	4.75	7.13	9.38	11.63	13.88
	16 to 25	2.75	5.00	7.38	9.63	11.88	14.13
	26 to 35	3.00	5.25	7.63	9.88	12.13	14.38
	36 to 51	3.25	5.50	7.88	10.13	12.38	14.63
	52 to 79	3.50	5.75	8.13	10.38	12.63	14.88
	80 to 100	3.75	6.00	8.38	10.63	12.88	15.13
	19 to 27	4.00	5.75	7.00	8.25	-	-
C	28 to 37	4.25	5.75	7.25	8.50	-	-
	38 to 46	4.50	6.00	7.50	8.75	10.25	11.75
	47 to 70	5.00	6.50	8.00	9.25	10.75	12.25
	71 to 81	5.50	7.00	8.50	9.75	11.25	12.75
	82 to 100	6.00	7.50	9.00	10.25	11.75	13.25

Tooth dimensions, inches

Dimension	Chain Width, Number of Strands					
	1	2	3	4	5	6
T	1.156	1.119	1.119	1.063	1.063	1.063
L	-	3.424	5.729	7.978	10.283	12.588
K	-	2.305	2.305	2.305	2.305	2.305
Machined sprockets +.000", -.019"						
Tolerances for T and L Hot rolled steel plate sprockets or unfinished forgings +.000", -.062"						

Recommended standard bore tolerances, keyseat dimensions, eccentricity tolerances, and similar data, page G-2.

Δ Non-functional dimension that may vary with the type of cutter used.

▲ Based on maximum hub diameter.

Drive Engineering

No. 180 chain 2.250" pitch

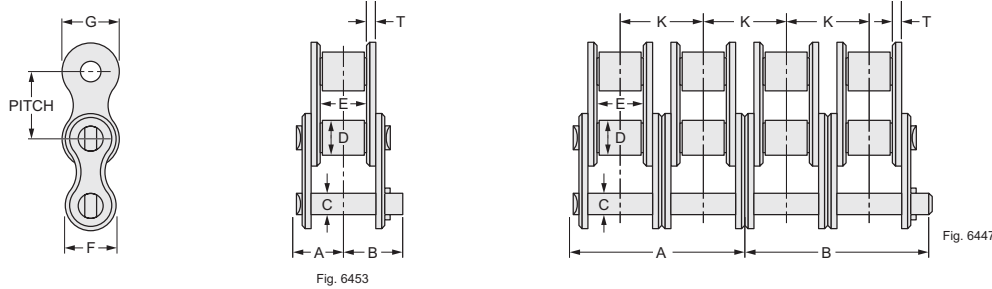

Specifications and dimensions

Chain Number	Chain Width, Number of Strands	Average ultimate strength, pounds	Joint bearing area, sq. in.	Weight per foot, pounds	Dimensions, inches								
					A	B	C	D	E	F	G	K	T
180	Single	86,000	1.364	9.06	1.39	1.56	.688	1.406	1.41	1.85	2.14	2.592	.28
180-2	Double	172,000	2.728	17.6	2.69	2.86	.688	1.406	1.41	1.85	2.14	2.592	.28
180-3	Triple	258,000	4.092	26.9	3.98	4.15	.688	1.406	1.41	1.85	2.14	2.592	.28
180-4	Quadruple	344,000	5.456	35.8	5.28	5.45	.688	1.406	1.41	1.85	2.14	2.592	.28
180-5	Quintuple	430,000	6.820	44.7	6.57	6.74	.688	1.406	1.41	1.85	2.14	2.592	.28
180-6	Sextuple	516,000	8.184	53.6	7.87	8.04	.688	1.406	1.41	1.85	2.14	2.592	.28

Available in riveted or cottered construction.

Ratings

Number of teeth, in small sprocket	Maximum bore inches	Horsepower for single strand chain ▲																				
		RPM of small sprocket																				
		10	25	50	100	150	200	250	300	350	400	450	500	550	600	650	700	800	900	1000	1100	
11	3.375	4.24	9.68	18.1	33.7	48.6	62.9	76.9	90.6	104	117	124	106	92.0	80.7	71.6	64.1	52.4	46.9	37.5	32.5	
12	4.000	4.66	10.6	19.8	37.0	53.4	69.1	84.5	99.6	114	129	142	121	105	92.0	81.6	73.0	59.7	50.1	42.8	37.1	
13	4.500	5.08	11.6	21.6	40.4	58.2	75.4	92.1	109	125	141	156	136	118	104	92.0	82.3	67.4	56.5	48.2	0	
14	5.375	5.51	12.6	23.4	43.7	63.0	81.6	99.8	118	135	152	169	152	132	116	103	92.0	75.3	63.1	53.9	0	
15	5.875	5.93	13.5	25.3	47.1	67.9	88.0	108	127	146	164	182	169	146	129	114	102	83.5	70.0	59.7	0	
16	6.250	6.36	14.5	27.1	50.5	72.8	94.3	115	136	156	176	196	186	161	142	126	112	92.0	77.1	65.8	0	
17	6.688	6.79	15.5	28.9	54.0	77.7	101	123	145	167	188	209	204	177	155	138	123	101	84.4	72.1	0	
18	7.375	7.22	16.5	30.8	57.4	82.7	107	131	154	177	200	222	222	193	169	150	134	110	92.0	78.5	0	
19	7.750	7.66	17.5	32.6	60.8	87.6	114	139	164	188	212	236	241	209	183	163	145	119	99.8	85.2	0	
20	8.250	8.10	18.5	34.5	64.3	92.6	120	147	173	199	224	249	260	226	198	176	157	129	108	92.0	0	
21	9.313	8.53	19.5	36.3	67.8	97.6	126	155	182	209	236	262	280	243	213	189	169	138	116	99.0	0	
22	-	8.97	20.5	38.2	71.3	103	133	163	192	220	248	276	300	260	228	203	181	148	124	0	-	
23	-	9.41	21.5	40.1	74.8	108	140	171	201	231	260	290	318	278	244	216	194	159	133	0	-	
24	-	9.86	22.5	42.0	78.3	113	146	179	210	242	273	303	333	296	260	231	206	169	142	0	-	
25	-	10.3	23.5	43.9	81.8	118	153	187	220	253	285	317	348	315	277	245	220	180	151	0	-	
28	-	11.6	26.6	49.6	92.5	133	173	211	249	286	322	358	394	374	328	291	260	213	178	0	-	
30	-	12.5	28.6	53.4	99.6	144	186	227	268	308	347	386	424	414	364	322	289	236	198	0	-	
32	-	13.4	30.7	57.2	107	154	199	244	287	330	372	414	455	456	401	355	318	260	0	-	-	
35	-	14.8	33.8	63.1	118	170	220	268	316	363	410	458	501	522	458	406	364	291	0	-	-	
40	-	17.1	39.0	72.9	136	196	254	310	365	420	473	526	579	575	524	465	398	244	0	-	-	
Lubrication type ■		A	B		C																	

The dotted line indicates the point at which pin and bushing galling is likely to begin. When the desired selection falls within the shaded area, consult Rexnord for guidance.

▲ Ratings are based on a service factor of 1. For a complete list of service factors, refer to Table 1, page C-7. The ratings listed above apply directly to lubricated, single strand, standard and heavy series roller chains. For multiple strand chains, apply the factors shown in the table at right. To select chains that vary in design or material from standard roller chain, use the factors in Table 3, page C-7.

■ Type A: Manual or drip (Maximum chain speed 95 FPM)
 Type B: Bath or disc (Maximum chain speed 950 FPM)
 Type C: Forced (pump)

Multiple strand factors

Number of strands	Multiple strand factor
2	1.7
3	2.5
4	3.3
5	4.1
6	5.0
7 or more	Consult Rexnord

No. 180 sprockets 2.250" pitch

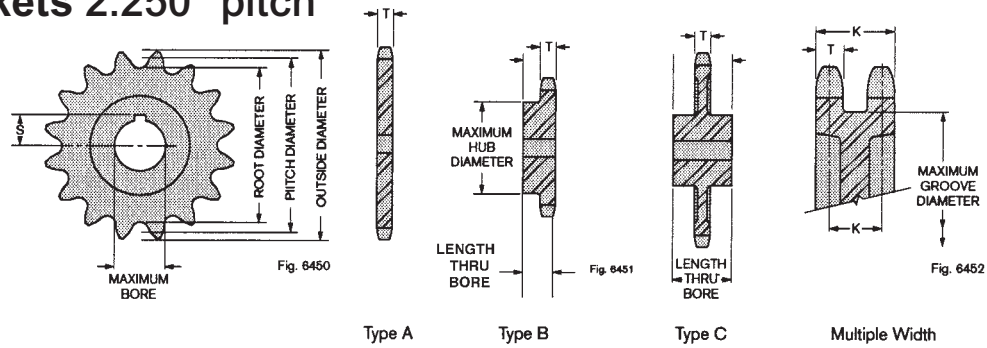

Dimensions

Number of teeth	Pitch diameter, inches	Root diameter, inches	Outside diameter, inches Δ	Maximum hub and groove diameter, inches	Maximum bore with standard keyseat, inches ▲	S max., inches	Type A				Type B				Type C				Multiple Width			
							Number of teeth	Pitch diameter, inches	Root diameter, inches	Outside diameter, inches Δ	Number of teeth	Pitch diameter, inches	Root diameter, inches	Outside diameter, inches Δ	Number of teeth	Pitch diameter, inches	Root diameter, inches	Outside diameter, inches Δ	Number of teeth	Pitch diameter, inches	Root diameter, inches	Outside diameter, inches Δ
8	5.879	4.473	6.782	3.14	2.000	1.250	39	27.962	26.556	29.221	70	50.151	48.745	51.451								
9	6.579	5.173	7.533	3.89	2.250	1.375	40	28.677	27.271	29.939	71	50.866	49.460	52.166								
10	7.281	5.875	8.276	4.64	2.875	1.813	41	29.393	27.987	30.656	72	51.583	50.177	52.884								
11	7.986	6.580	9.014	5.38	3.375	2.125	42	30.108	28.702	31.374	73	52.299	50.893	53.600								
12	8.693	7.287	9.747	6.11	4.000	2.500	43	30.824	29.418	32.092	74	53.015	51.609	54.317								
13	9.402	7.996	10.478	6.84	4.500	2.750	44	31.539	30.133	32.810	75	53.730	52.324	55.033								
14	10.112	8.706	11.207	7.58	5.375	3.313	45	32.255	30.849	33.527	76	54.446	53.040	55.751								
15	10.822	9.416	11.934	8.30	5.875	3.688	46	32.971	31.565	34.243	77	55.162	53.746	56.466								
16	11.533	10.127	12.661	9.03	6.250	3.875	47	33.686	32.280	34.961	78	55.879	54.473	57.184								
17	12.245	10.839	13.385	9.75	6.688	4.094	48	34.402	32.996	35.678	79	56.594	55.188	57.899								
18	12.957	11.551	14.110	10.47	7.375	4.438	49	35.118	33.712	36.396	80	57.310	55.904	58.617								
19	13.670	12.264	14.834	11.20	7.750	4.750	50	35.834	34.428	37.114	81	58.027	56.621	59.333								
20	14.383	12.977	15.557	11.92	8.250	5.000	51	36.549	35.143	37.829	82	58.743	57.337	60.050								
21	15.096	13.690	16.279	12.64	9.313	5.531	52	37.265	35.859	38.547	83	59.459	58.053	60.766								
22	15.810	14.404	16.999	13.36	-	-	53	37.981	36.575	39.265	84	60.175	58.769	61.484								
23	16.524	15.118	17.721	14.08	-	-	54	38.696	37.290	39.980	85	60.891	59.485	62.199								
24	17.238	15.832	18.441	14.80	-	-	55	39.412	38.006	40.698	86	61.607	60.201	62.915								
25	17.952	16.546	19.161	15.52	-	-	56	40.128	38.722	41.416	87	62.323	60.917	63.632								
26	18.666	17.260	19.881	16.25	-	-	57	40.844	39.438	42.131	88	63.039	61.633	64.348								
27	19.381	17.975	20.601	16.97	-	-	58	41.560	40.154	42.849	89	63.755	62.349	65.066								
28	20.096	18.690	21.319	17.69	-	-	59	42.276	40.870	43.567	90	64.471	63.065	65.781								
29	20.810	19.404	22.039	18.41	-	-	60	42.991	41.585	44.282	91	65.187	63.781	66.499								
30	21.525	20.119	22.757	19.13	-	-	61	43.707	42.301	45.000	92	65.903	64.497	67.214								
31	22.240	20.834	23.477	19.84	-	-	62	44.423	43.017	45.716	93	66.619	65.213	67.932								
32	22.955	21.549	24.194	20.56	-	-	63	45.139	43.733	46.433	94	67.335	65.929	68.648								
33	23.670	22.264	24.914	21.28	-	-	64	45.855	44.449	47.151	95	68.051	66.645	69.363								
34	24.385	22.979	25.632	22.00	-	-	65	46.571	45.165	47.867	96	68.767	67.361	70.081								
35	25.101	23.695	26.350	22.72	-	-	66	47.287	45.881	48.584	97	69.483	68.077	70.796								
36	25.816	24.410	27.068	23.44	-	-	67	48.003	46.597	49.300	98	70.199	68.793	71.514								
37	26.531	25.125	27.785	24.16	-	-	68	48.719	47.313	50.018	99	70.916	69.510	72.230								
38	27.246	25.840	28.503	24.86	-	-	69	49.435	48.029	50.733	100	71.631	70.225	72.947								

Larger sizes available.

Hub length thru bore, inches

Sprocket Type	Number of Teeth	Chain Width, Number of Strands					
		1	2	3	4	5	6
B	7 to 10	2.50	5.00	7.50	10.00	12.50	15.00
	11 to 13	2.75	5.25	7.75	10.25	12.75	15.25
	14 to 17	3.00	5.50	8.00	10.50	13.00	15.50
	18 to 23	3.25	5.75	8.25	10.75	13.25	15.75
	24 to 34	3.50	6.00	8.50	11.00	13.50	16.00
	35 to 52	4.00	6.50	9.00	11.50	14.00	16.50
	53 to 72	4.50	7.00	9.50	12.00	14.50	17.00
	73 to 90	5.00	7.50	10.00	12.50	15.00	17.50
	91 to 100	5.50	8.00	10.50	13.00	15.50	18.00
	C	24 to 34	4.50	6.25	7.75	9.50	-
35 to 52		5.00	6.75	8.25	10.00	11.75	13.50
53 to 72		5.50	7.25	8.75	10.50	12.25	14.00
73 to 90		6.25	8.00	9.50	11.25	13.00	14.75
91 to 100		7.00	8.75	10.25	12.00	13.75	15.50

Tooth dimensions, inches

Dimension	Chain Width, Number of Strands					
	1	2	3	4	5	6
T	1.301	1.259	1.259	1.198	1.198	1.198
L	-	3.851	6.443	8.974	11.566	14.158
K	-	2.592	2.592	2.592	2.592	2.592
Machined sprockets +.000", -.020"						
Tolerances for T and L Hot rolled steel plate sprockets or unfinished forgings +.000", -.068"						

Recommended standard bore tolerances, keyseat dimensions, eccentricity tolerances, and similar data, page G-2.

Δ Non-functional dimension that may vary with the type of cutter used.

▲ Based on maximum hub diameter.

Drive Engineering

No. 200 chain 2.500" pitch

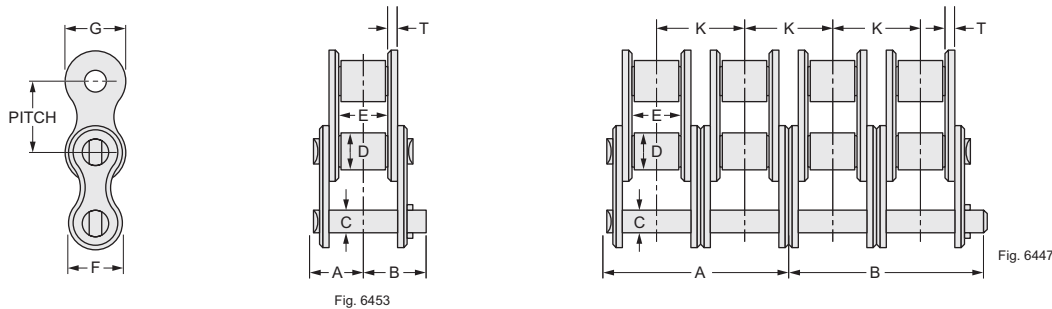

Specifications and dimensions

Chain Number	Chain Width, Number of Strands	Average ultimate strength, pounds	Joint bearing area, sq. in.	Weight per foot, pounds	Dimensions, inches								
					A	B	C	D	E	F	G	K	T
200	Single	100,000	1.681	10.9	1.54	1.89	.781	1.563	1.50	1.94	2.31	2.817	.31
200-2	Double	200,000	3.362	21.0	2.96	3.31	.781	1.563	1.50	1.94	2.31	2.817	.31
200-3	Triple	300,000	5.043	31.5	4.38	4.73	.781	1.563	1.50	1.94	2.31	2.817	.31
200-4	Quadruple	400,000	6.724	43.2	5.80	6.14	.781	1.563	1.50	1.94	2.31	2.817	.31
200-5	Quintuple	500,000	8.405	53.9	7.22	7.56	.781	1.563	1.50	1.94	2.31	2.817	.31
200-6	Sextuple	600,000	10.086	64.6	8.64	8.98	.781	1.563	1.50	1.94	2.31	2.817	.31

Available in riveted or cottered construction.

Ratings

Number of teeth, in small sprocket	Maximum bore inches	Horsepower for single strand chain ▲																			
		RPM of small sprocket																			
		10	15	20	30	40	50	70	100	150	200	250	300	350	400	450	500	550	600	650	700
9	2.625	4.54	6.54	8.47	12.2	15.8	19.3	26.1	36.0	51.9	67.3	82.2	96.9	111	119	100	85.4	74.1	65.0	57.6	0
10	3.125	5.08	7.32	9.49	13.7	17.7	21.6	29.3	40.4	58.2	75.4	92.1	109	125	140	117	100	86.7	76.1	67.5	0
11	3.750	5.64	8.12	10.5	15.1	19.6	24.0	32.5	44.8	64.5	83.5	102	120	138	156	135	115	100	87.8	77.9	0
12	4.625	6.19	8.92	11.6	16.6	21.6	26.4	35.7	49.2	70.8	91.8	112	132	152	171	154	132	114	100	0	-
13	5.250	6.75	9.72	12.6	18.1	23.5	28.7	38.9	53.6	77.2	100	122	144	166	187	174	148	129	113	0	-
14	5.875	7.31	10.5	13.6	19.7	25.5	31.1	42.1	58.1	83.7	108	132	156	179	202	194	166	144	126	0	-
15	6.125	7.88	11.3	14.7	21.2	27.4	33.5	45.4	62.6	90.1	117	143	168	193	218	215	184	159	140	0	-
16	6.688	8.45	12.2	15.8	22.7	29.4	36.0	48.7	67.1	96.6	125	153	180	207	234	237	203	176	154	0	-
17	7.688	9.02	13.0	16.8	24.2	31.4	38.4	52.0	71.6	103	134	163	193	221	249	260	222	192	169	0	-
18	8.375	9.59	13.8	17.9	25.8	33.4	40.8	55.3	76.2	110	142	174	205	235	265	283	242	209	184	0	-
19	9.125	10.2	14.6	19.0	27.3	35.4	43.3	58.6	80.8	116	151	184	217	249	281	307	262	227	199	0	-
20	9.750	10.7	15.5	20.1	28.9	37.4	45.8	61.9	85.4	123	159	195	229	264	297	331	283	245	0	-	-
21	-	11.3	16.3	21.1	30.5	39.5	48.2	65.3	90.0	130	168	205	242	278	313	348	305	264	0	-	-
22	-	11.9	17.2	22.2	32.0	41.5	50.7	68.7	94.6	136	177	216	254	292	330	366	327	283	0	-	-
23	-	12.5	18.0	23.3	33.6	43.5	53.2	72.0	99.3	143	185	226	267	307	346	384	349	303	0	-	-
24	-	13.1	18.9	24.4	35.2	45.6	55.7	75.4	104	150	194	237	279	321	362	402	372	323	0	-	-
25	-	13.7	19.7	25.5	36.8	47.6	58.2	78.8	109	156	203	248	292	335	378	421	396	343	0	-	-
26	-	14.3	20.6	26.6	38.4	49.7	60.7	82.2	113	163	212	259	305	350	395	439	420	364	0	-	-
Lubrication type ■		A			B						C										

The dotted line indicates the point at which pin and bushing galling is likely to begin. When the desired selection falls within the shaded area, consult Rexnord for guidance.

▲ Ratings are based on a service factor of 1. For a complete list of service factors, refer to Table 1, page C-7. The ratings listed above apply directly to lubricated, single strand, standard and heavy series roller chains. For multiple strand chains, apply the factors shown in the table at right. To select chains that vary in design or material from standard roller chain, use the factors in Table 3, page C-7.

■ Type A: Manual or drip (Maximum chain speed 95 FPM)
 Type B: Bath or disc (Maximum chain speed 950 FPM)
 Type C: Forced (pump)

Multiple strand factors

Number of strands	Multiple strand factor
2	1.7
3	2.5
4	3.3
5	4.1
6	5.0
7 or more	Consult Rexnord

No. 200 sprockets 2.500" pitch

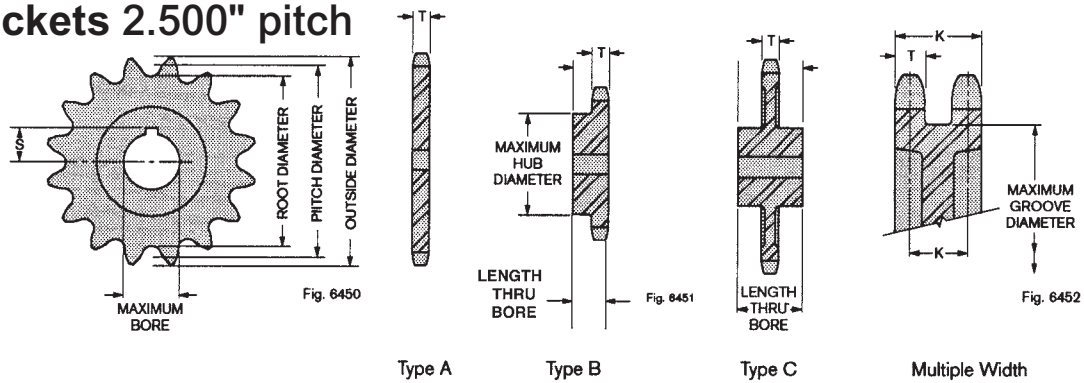

Dimensions

Number of teeth	Pitch diameter, inches	Root diameter, inches	Outside diameter, inches Δ	Maximum hub and groove diameter, inches	Maximum bore with standard keyseat, inches ▲	S max., inches	Number of teeth	Pitch diameter, inches	Root diameter, inches	Outside diameter, inches Δ	Number of teeth	Pitch diameter, inches	Root diameter, inches	Outside diameter, inches Δ
8	6.532	4.970	7.535	3.50	2.250	1.375	39	31.070	29.508	32.468	70	55.722	54.160	57.168
9	7.310	5.748	8.368	4.33	2.625	1.625	40	31.865	30.303	33.265	71	56.517	54.955	57.963
10	8.090	6.528	9.195	5.16	3.125	1.938	41	32.660	31.098	34.063	72	57.315	55.753	58.760
11	8.872	7.310	10.015	5.98	3.750	2.313	42	33.455	31.893	34.860	73	58.110	56.548	59.555
12	9.660	8.098	10.830	6.80	4.625	2.813	43	34.250	32.688	35.658	74	58.905	57.343	60.353
13	10.447	8.885	11.643	7.61	5.250	3.250	44	35.045	33.483	36.455	75	59.700	58.138	61.148
14	11.235	9.673	12.455	8.42	5.875	3.688	45	35.840	34.278	37.253	76	60.495	58.933	61.945
15	12.025	10.463	13.263	9.22	6.125	3.828	46	36.635	35.073	38.048	77	61.292	59.730	62.740
16	12.815	11.253	14.068	10.03	6.688	4.094	46	37.430	35.868	38.845	78	62.087	60.525	63.538
17	13.605	12.043	14.875	10.84	7.688	4.719	48	38.225	36.663	39.643	79	62.882	61.320	64.333
18	14.397	12.835	15.678	11.64	8.375	5.063	49	39.020	37.458	40.440	80	63.677	62.115	65.130
19	15.190	13.628	16.483	12.44	9.125	5.438	50	39.815	38.253	41.238	81	64.475	62.913	65.925
20	15.982	14.420	17.285	13.25	9.750	5.750	51	40.610	39.048	42.033	82	65.270	63.708	66.723
21	16.775	15.213	18.088	14.05	-	-	52	41.405	39.843	42.830	83	66.065	64.503	67.518
22	17.567	16.005	18.888	14.84	-	-	53	42.200	40.638	43.628	84	66.860	65.298	68.315
23	18.360	16.798	19.688	15.66	-	-	54	42.995	41.433	44.423	85	67.657	66.095	69.110
24	19.152	17.590	20.490	16.45	-	-	55	43.792	42.230	45.220	86	68.452	66.890	69.905
25	19.947	18.385	21.290	17.25	-	-	56	44.587	43.025	46.015	87	69.247	67.685	70.703
26	20.740	19.178	22.090	18.05	-	-	57	45.382	43.820	46.813	88	70.042	68.480	71.498
27	21.535	19.973	22.890	18.86	-	-	58	46.177	44.615	47.610	89	70.837	69.275	72.295
28	22.330	20.768	23.688	19.59	-	-	59	46.972	45.410	48.408	90	71.635	70.073	73.090
29	23.122	21.560	24.488	20.45	-	-	60	47.767	46.205	49.203	91	72.430	70.868	73.890
30	23.917	22.355	25.285	21.25	-	-	61	48.565	47.003	50.000	92	73.225	71.663	74.680
31	24.712	23.150	26.085	22.05	-	-	62	49.360	47.798	50.795	93	74.020	72.458	75.480
32	25.505	23.943	26.883	22.84	-	-	63	50.155	48.593	51.593	94	74.815	73.253	76.280
33	26.300	24.738	27.680	23.64	-	-	64	50.950	49.388	52.388	95	75.612	74.050	77.070
34	27.095	25.533	28.480	24.44	-	-	75	51.745	50.183	53.185	96	76.407	74.845	77.870
35	27.890	26.328	29.278	25.23	-	-	66	52.540	50.978	53.983	97	77.202	75.640	78.660
36	28.685	27.123	30.075	26.03	-	-	67	53.337	51.775	54.778	98	77.997	76.435	79.460
37	29.480	27.918	30.873	26.84	-	-	68	54.132	52.570	55.575	99	78.795	77.233	80.260
38	30.275	28.713	31.670	27.64	-	-	69	54.927	53.365	56.370	100	79.590	78.028	81.050

Larger sizes available.

Hub length thru bore, inches

Sprocket Type	Number of Teeth	Chain Width, Number of Strands					
		1	2	3	4	5	6
B	8 to 11	3.00	5.75	8.75	11.50	14.25	17.00
	12 to 22	3.50	6.25	9.25	12.00	14.75	17.50
	23 to 36	4.00	6.75	9.75	12.50	15.25	18.00
	37 to 47	4.50	7.25	10.25	13.00	15.75	18.50
	48 to 60	5.00	7.75	10.75	13.50	16.25	19.00
	61 to 78	5.50	8.25	11.25	14.00	16.75	19.50
	79 to 100	6.00	8.75	11.75	14.50	17.25	20.00
	16 to 22	4.50	6.25	8.00	9.75	-	-
C	23 to 35	5.00	6.75	8.50	10.25	12.00	13.75
	36 to 50	5.50	7.25	9.00	10.75	12.50	14.25
	51 to 64	6.00	7.75	9.50	11.25	13.00	14.75
	65 to 75	6.50	8.25	10.00	11.75	13.50	15.25
	76 to 82	7.00	8.75	10.50	12.25	14.00	15.75
	83 to 100	7.50	9.25	11.00	12.75	14.50	16.25

Tooth dimensions, inches

Dimension	Chain Width, Number of Strands					
	1	2	3	4	5	6
T	1.389	1.344	1.344	1.278	1.278	1.278
L	-	4.161	6.978	9.729	12.546	15.363
K	-	2.817	2.817	2.817	2.817	2.817
Machined sprockets +.000", -.021"						
Hot rolled steel plate sprockets or unfinished forgings +.000", -.072"						

Tolerances for T and L

Recommended standard bore tolerances, keyseat dimensions, eccentricity tolerances, and similar data, page G-2.

Δ Non-functional dimension that may vary with the type of cutter used.

▲ Based on maximum hub diameter.

Drive Engineering

No. 240 chain 3.000" pitch

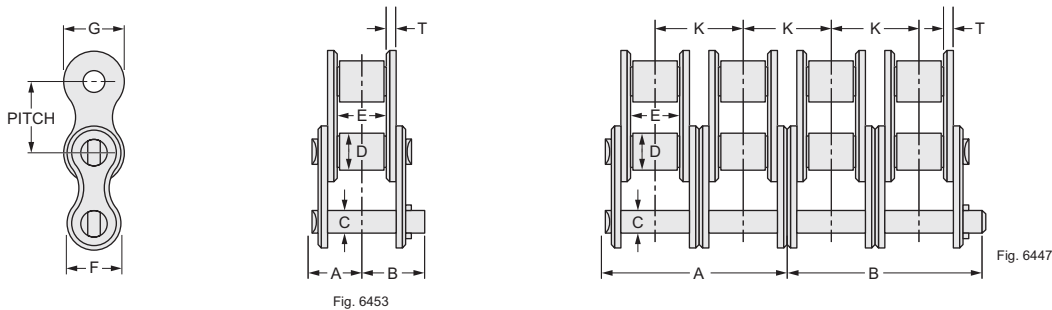

Specifications and dimensions

Chain Number	Chain Width, Number of Strands	Average ultimate strength, pounds	Joint bearing area, sq. in.	Weight per foot, pounds	Dimensions, inches								
					A	B	C	D	E	F	G	K	T
240	Single	152,200	2.488	16.4	1.85	2.20	.938	1.875	1.88	2.44	2.81	3.458	.38
240-2	Double	304,400	4.976	32.2	3.58	3.93	.938	1.875	1.88	2.44	2.81	3.458	.38
240-3	Triple	456,600	7.464	49.4	5.31	5.75	.938	1.875	1.88	2.44	2.81	3.458	.38
240-4	Quadruple	608,800	9.952	65.7	7.04	7.38	.938	1.875	1.88	2.44	2.81	3.458	.38
240-5	Quintuple	761,000	10.440	82.0	8.76	9.11	.938	1.875	1.88	2.44	2.81	3.458	.38
240-6	Sextuple	913,200	14.928	98.4	10.50	10.84	.938	1.875	1.88	2.44	2.81	3.458	.38

Available in riveted and cotteder construction.

Ratings

Number of teeth, in small sprocket	Maximum bore inches	Horsepower for single strand chain ▲																			
		RPM of small sprocket																			
		5	10	15	20	25	30	40	50	60	80	100	125	150	175	200	250	300	350	400	450
9	3.250	3.92	7.31	10.5	13.6	16.7	19.6	25.4	31.1	36.7	47.5	58.1	71.0	83.6	96.1	108	132	156	169	138	116
10	4.000	4.39	8.19	11.8	15.3	18.7	22.0	28.5	34.9	41.1	53.2	65.0	79.5	93.7	108	121	148	175	198	162	136
11	4.500	4.86	9.08	13.1	16.9	20.7	24.4	31.6	38.6	45.5	59.0	72.1	88.1	104	119	135	164	194	223	187	156
12	5.500	5.34	9.97	14.4	18.6	22.7	26.8	34.7	42.4	50.0	64.8	79.2	96.8	114	131	148	181	213	245	213	0
13	6.250	5.83	10.9	15.7	20.3	24.8	29.2	37.9	46.3	54.5	70.6	86.4	106	124	143	161	197	232	267	240	0
14	7.875	6.31	11.8	17.0	22.0	26.9	31.7	41.0	50.1	59.1	76.5	93.6	114	135	155	175	213	251	289	268	0
15	8.813	6.80	12.7	18.3	23.7	28.9	34.1	44.2	54.0	63.6	82.4	101	123	145	167	188	230	271	311	297	0
16	9.688	7.29	13.6	19.6	25.4	31.0	36.6	47.4	57.9	68.2	88.4	108	132	156	179	202	247	290	334	328	0
17	-	7.78	14.5	20.9	27.1	33.1	39.0	50.6	61.8	72.9	94.4	115	141	166	191	215	263	310	356	359	0
18	-	8.28	15.4	22.3	28.8	35.2	41.5	53.8	65.8	77.5	100	123	150	177	203	229	280	330	379	377	0
19	-	8.78	16.4	23.6	30.6	37.4	44.0	57.0	69.7	82.2	106	130	159	187	215	243	297	350	402	393	0
20	-	9.28	17.3	24.9	32.3	39.5	46.5	60.3	73.7	86.8	112	138	168	198	228	257	314	370	423	407	0
21	-	9.78	18.2	26.3	34.1	41.6	49.0	63.5	77.7	91.5	119	145	177	209	240	270	331	390	439	421	0
22	-	10.3	19.2	27.6	35.8	43.8	51.6	66.8	81.7	96.2	125	152	186	220	252	284	348	410	454	435	0
23	-	10.8	20.1	29.0	37.6	45.9	54.1	70.1	85.7	101	131	160	195	230	265	298	365	430	469	448	0
24	-	11.3	21.1	30.4	39.3	48.1	56.7	73.4	89.7	106	137	167	205	241	277	312	382	450	483	0	-
25	-	11.8	22.0	31.7	41.1	50.3	59.2	76.7	93.8	110	143	175	214	252	290	327	399	470	496	0	-
26	-	12.3	23.0	33.1	42.9	52.4	61.8	80.0	97.8	115	149	183	223	263	302	341	416	491	509	0	-
Lubrication type ■		A			B									C							

The dotted line indicates the point at which pin and bushing galling is likely to begin. When the desired selection falls within the shaded area, consult Rexnord for guidance.

▲ Ratings are based on a service factor of 1. For a complete list of service factors, refer to Table 1, page C-7. The ratings listed above apply directly to lubricated, single strand, standard and heavy series roller chains. For multiple strand chains, apply the factors shown in the table at right. To select chains that vary in design or material from standard roller chain, use the factors in Table 3, page C-7.

■ Type A: Manual or drip (Maximum chain speed 95 FPM)
 Type B: Bath or disc (Maximum chain speed 950 FPM)
 Type C: Forced (pump)

Multiple strand factors

Number of strands	Multiple strand factor
2	1.7
3	2.5
4	3.3
5	4.1
6	5.0
7 or more	Consult Rexnord

No. 240 sprockets 3.000" pitch

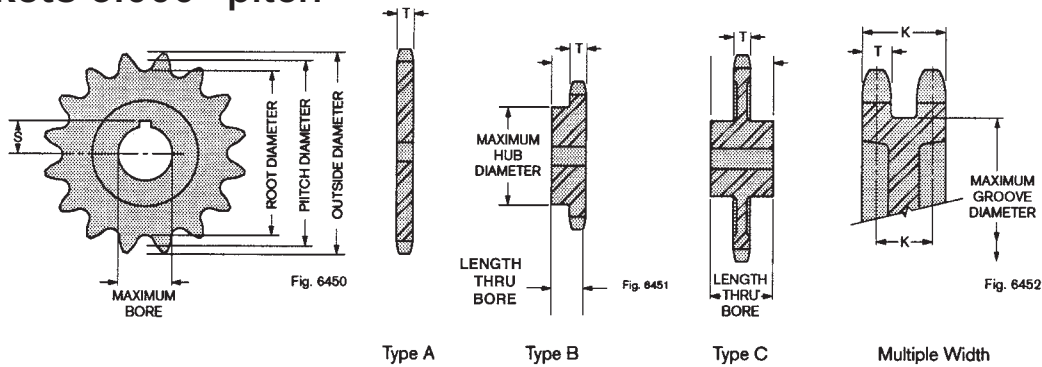

Dimensions

Number of teeth	Pitch diameter, inches	Root diameter, inches	Outside diameter, inches Δ	Maximum hub and groove diameter, inches	Maximum bore with standard keyseat, inches \blacktriangle	S max., inches	Type A				Multiple Width			
							Number of teeth	Pitch diameter, inches	Root diameter, inches	Outside diameter, inches Δ	Number of teeth	Pitch diameter, inches	Root diameter, inches	Outside diameter, inches Δ
8	7.893	5.964	9.042	4.20	2.983	1.844	39	37.283	35.408	38.961	70	66.868	64.993	68.601
9	8.771	6.896	10.044	5.20	3.250	2.000	40	38.237	36.362	39.918	71	67.822	69.947	69.555
10	9.708	7.833	11.034	6.20	4.000	2.500	41	39.191	37.316	40.875	72	68.777	66.902	70.512
11	10.649	8.774	12.018	7.19	4.500	2.750	42	40.145	38.270	41.832	73	69.731	67.856	71.466
12	11.591	9.716	12.996	8.16	5.500	3.375	43	41.099	39.224	42.789	74	70.686	68.811	72.423
13	12.536	10.661	13.971	9.14	6.250	3.875	44	42.053	40.178	43.746	75	71.641	69.766	73.377
14	13.482	11.607	14.943	10.11	7.875	4.688	45	43.007	41.132	44.703	76	72.595	70.720	74.334
15	14.492	12.554	15.912	11.08	8.813	5.281	46	43.961	42.086	45.657	77	73.550	71.675	75.288
16	15.377	13.502	16.881	12.05	9.688	5.719	47	44.915	43.040	46.614	78	74.505	72.630	76.245
17	16.327	14.452	17.847	13.02	-	-	48	45.869	43.994	47.571	79	75.459	73.584	77.199
18	17.276	15.401	18.813	13.98	-	-	49	46.824	44.949	48.528	80	76.414	74.539	78.156
19	18.227	16.352	19.779	14.94	-	-	50	47.778	45.903	49.485	81	77.369	75.494	79.110
20	19.177	17.302	20.742	15.91	-	-	51	48.732	46.857	50.439	82	78.323	76.448	80.067
21	20.129	18.254	21.705	16.88	-	-	52	49.687	47.812	51.396	83	79.278	77.403	80.021
22	21.080	19.205	22.665	17.83	-	-	53	50.641	48.766	52.353	84	80.233	78.358	81.978
23	22.032	20.157	23.628	18.80	-	-	54	51.595	49.720	53.307	85	81.188	79.313	82.932
24	22.984	21.109	24.588	19.75	-	-	55	52.550	50.675	54.264	86	82.142	80.267	83.886
25	23.936	22.061	25.548	20.70	-	-	56	53.504	51.629	55.221	87	83.097	81.222	84.843
26	24.889	23.014	26.508	21.67	-	-	57	54.458	52.583	56.175	88	84.052	82.177	85.797
27	25.841	23.966	27.468	22.63	-	-	58	55.413	53.538	57.132	89	85.006	83.131	86.754
28	26.794	24.919	28.425	23.59	-	-	59	56.368	54.493	58.089	90	85.961	84.086	87.708
29	27.747	25.872	29.385	24.55	-	-	60	57.322	55.447	59.043	91	86.916	85.041	88.665
30	28.700	26.825	30.342	25.50	-	-	61	58.277	56.402	60.000	92	87.871	85.996	89.619
31	29.654	27.779	31.302	26.47	-	-	62	59.231	57.356	60.954	93	88.825	86.950	90.576
32	30.607	28.732	32.259	27.42	-	-	63	60.185	58.310	61.911	94	89.780	87.905	91.530
33	31.560	29.685	33.219	28.38	-	-	64	61.140	59.265	62.868	95	90.735	88.860	92.484
34	32.514	30.639	34.176	29.34	-	-	65	62.095	60.220	63.822	96	91.690	89.815	93.441
35	33.467	31.592	35.133	30.30	-	-	66	63.049	61.174	64.779	97	92.645	90.770	94.395
36	34.421	32.546	36.090	31.25	-	-	67	64.004	62.129	65.733	98	93.599	91.724	95.352
37	35.375	33.500	37.047	32.22	-	-	68	64.958	63.083	66.690	99	94.554	92.679	96.306
38	36.329	34.454	38.004	33.17	-	-	69	65.913	64.038	67.644	100	95.509	93.634	97.263

Larger sizes available.

Hub length thru bore, inches

Sprocket Type	Number of Teeth	Chain Width, Number of Strands					
		1	2	3	4	5	6
B	7 to 10	3.25	6.75	10.25	13.75	17.25	20.75
	11 to 15	4.00	7.50	11.00	14.50	18.00	21.50
	16 to 22	4.50	8.00	11.50	15.00	18.50	22.00
	23 to 31	5.00	8.50	12.00	15.50	19.00	22.50
	32 to 38	5.50	9.00	12.50	16.00	19.50	23.00
	39 to 52	6.00	9.50	13.00	16.50	20.00	23.50
	53 to 65	6.50	10.00	13.50	17.00	20.50	24.00
	66 to 82	7.00	10.50	14.00	17.50	21.00	24.50
	83 to 100	7.50	11.00	14.50	18.00	21.50	25.00
	C	23 to 31	6.25	8.50	10.50	12.75	15.00
32 to 38		7.00	9.25	11.25	13.50	15.75	18.00
39 to 52		7.75	10.00	12.00	14.25	16.50	18.75
53 to 65		8.50	10.75	12.75	15.00	17.25	19.50
66 to 82		9.00	11.25	13.25	15.50	17.75	20.00
83 to 100		9.75	12.00	14.00	16.25	18.50	20.75

Tooth dimensions, inches

Dimension	Chain Width, Number of Strands					
	1	2	3	4	5	6
T	1.738	1.682	1.682	1.601	1.601	1.601
L	-	5.139	8.596	11.972	15.429	18.886
K	-	3.458	3.458	3.458	3.458	3.458
Tolerances for T and L						
Machined sprockets +.000", -.025"						
Hot rolled steel plate sprockets or unfinished forgings +.000", -.088"						

Recommended standard bore tolerances, keyseat dimensions, eccentricity tolerances, and similar data, page G-2.

Δ Non-functional dimension that may vary with the type of cutter used.

\blacktriangle Based on maximum hub diameter.

Drive Engineering Lubrication

Generally, chains should be lubricated to achieve and maintain high operating efficiency and provide long service life. Factors such as operating conditions, chain size, type of service, and method of lubrication influence the life of chain. Many low-speed drives perform successfully with little lubrication, but where operating conditions permit, longer chain life will result from adequate lubrication.

The primary purpose of chain lubrication is to provide a clean film of oil at all load-carrying points where relative motion occurs. To effectively lubricate the chain joints, oil must be delivered to the spaces indicated in Figure 7913. The oil should be directed to the inside of the lower span of chain so that it will not be thrown off by centrifugal force before it penetrates the chain joint.

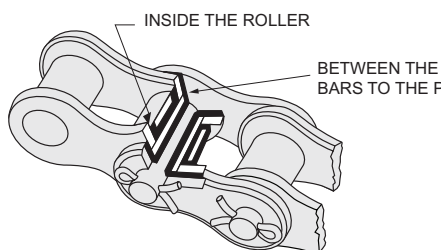

Factory Prelubrication

Laboratory tests and actual experience show that chain joint friction is greatest during the run-in period, the span of time between drive start-up and the point at which the lubrication system begins to function effectively. To minimize joint friction during this critical period of operation, Rexnord roller chains are factory prelubricated.

Laboratory tests show that prelubrication reduces joint wear during the critical run-in period by approximately 50%. The result is longer operating life for the chain.

Subsequent maintenance of a clean oil film between all bearing surfaces is equally important for high operating efficiency.

Selection of the Lubricant

Drives operating at room temperatures should be lubricated with an S.A.E. 30 mineral oil. For operation at high or low temperature extremes, oils with higher or lower viscosity numbers should be used, such as those listed below.

Temperature of atmosphere surrounding drive, degrees Fahrenheit	S.A.E. viscosity number
-20 to 40	20
40 to 100	30
100 to 120	40
120 to 140	50

Petroleum oils should not be used to lubricate drive chains operating in temperatures above 300°F (149° Celsius). Under certain operating conditions, chains operating in high temperature atmospheres can be effectively lubricated with colloidal graphite dispersed in a suitable volatile carrier. These solutions penetrate the chain joints and, upon evaporation of the carrier, leave a thin deposit of graphite on the chain joint surfaces. This type of lubricant may be applied by drip-feed or wick-feed oil cups. Consult a lubricant manufacturer for recommendations when chains are required to operate at temperatures between 300°F and 700°F (149° and 371°C).

Suggested Methods of Lubrication

Several methods for lubricating chain drives have been developed, each fitting a particular range of operating conditions. Horsepower, chain speed, and the relative position of shafts are primary considerations. The various methods suggested and their range of application are described below.

Manual or drip lubrication may be used for open running drives (those enclosed by a safety guard) which operate in a non-abrasive atmosphere. These methods should be confined to low horsepower drives operating at low chain speeds. The lubricant may be applied to the clearances between sidebars with a brush, oil can, or drip-cup oiler.

Drip-cups are usually mounted on a pipe with drilled holes spaced to distribute oil between the sidebars in the lower span of chain. About 4 to 10 drops per minute are sufficient to lubricate very slow speed drives, while a minimum of 20 drops per minute is recommended for higher speeds.

The relative position of shafts is not a factor when these methods of lubrication are used.

Bath lubrication is the simplest automatic method of lubricating encased chain drives and is highly satisfactory for low or moderate speeds.

The chain dips into an oil reservoir to a depth of about one-half inch, forcing the lubricant into the chain joints. Only a short length of chain should run through the oil, preferably only that portion on the bottom of the lower sprocket.

The relative shaft positions illustrated below are recommended when oil bath lubrication is used:

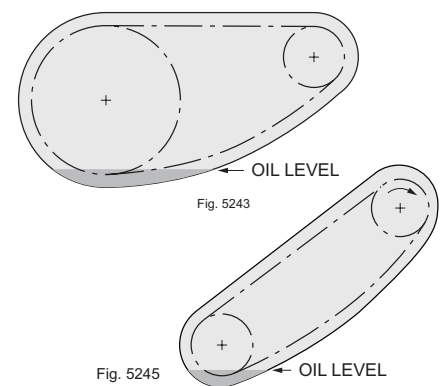
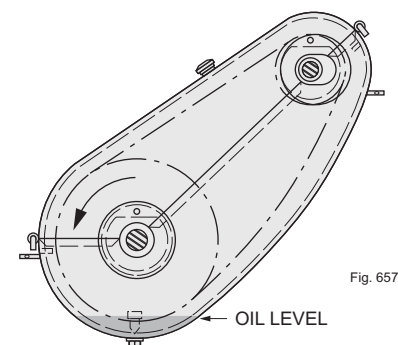

Disc lubrication is very effective for moderately high-speed drives and is frequently used when the drive arrangement is not suitable for oil bath lubrication.

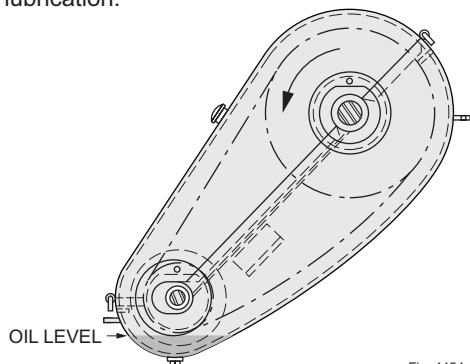

Fig. 4454

Forced lubrication is recommended for large horsepower drives, heavily loaded drives, high speed drives, or where oil bath or oil disc lubrication cannot be used.

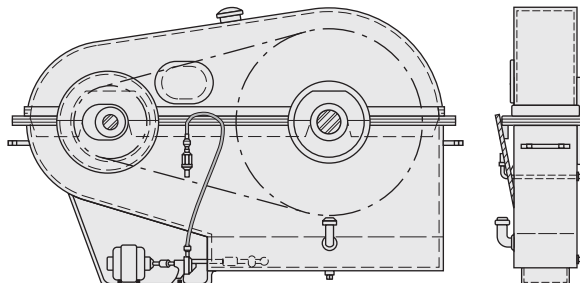

Fig. 4245

An oil disc mounted on the lower sprocket dips about one-half inch into an oil reservoir. The oil is thrown off the disc by centrifugal force, automatically lubricating the chain which is kept above the oil level. This method of lubrication is ineffective at high speeds as well as at very low speeds.

Oil disc lubrication is applicable to the relative shaft positions illustrated below:

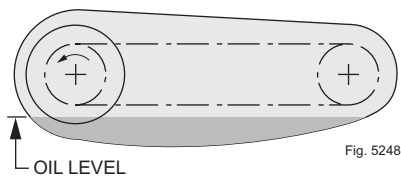

Fig. 5248

Small ratio with horizontal centers

An oil pump is provided to supply a continuous spray of oil to the inside of the lower span of chain. The circulation of the lubricant aids in the dissipation of heat and results in a well-lubricated, cooler operating drive.

The pump is usually direct-connected to a fractional horsepower motor as illustrated in Figure 4245. A chain driven pump, operating from either the driving or driven shaft may be used where electric power is not available. Pumps of about one-gallon-per-minute capacity are adequate for most drives under 200 hp.

The relative position of shafts is not a factor when forced lubrication is used.

Chain Casings

Oil-retaining casings are an integral part of the lubricating system when the oil bath, disc, or forced methods of lubrication are used.

As a safety feature, guard-type casings are required for drives lubricated by the manual or drip-cup methods.

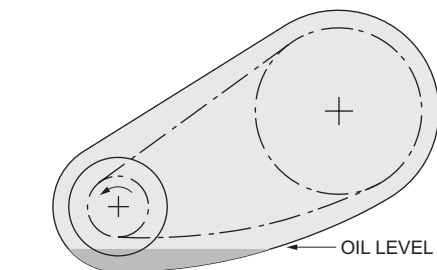

Fig. 5247

Large ratio with small sprocket low

Drive Engineering

Drive Installation

Accurate alignment, proper chain tension, good lubrication, and periodic inspection are required to obtain maximum chain and sprocket life.

For safe installation of chain and sprockets, careful attention should be given to the following instructions.

Caution: Shut off all power to the equipment so that it cannot be started accidentally during these installation steps. Failure to do so can result in serious personal injury.

Shaft alignment Mount the sprockets on their respective shafts. As illustrated in Photo 33635, align the shafts horizontally with a machinist's level, and adjust the shafts for parallel alignment with a vernier, caliper, or feeler bar. The distance between shafts on both sides of the sprockets must be equal. When shafts have been accurately aligned, the motor, bearings, etc., should be bolted securely in place so that alignment will be maintained during operation.

Sprocket alignment Sprockets must be in axial alignment for correct chain and sprocket tooth engagement. Apply a straight edge, or heavy cord to the machined sprocket surfaces as shown in Photo 33636. When a shaft is subject to end flat, the sprocket should be aligned for the normal running position. Tighten set screws in sprocket hubs to guard against lateral movement and to hold key in position.

Chain installation Inspect chain to make sure it is free from dirt or grit before it is installed. Fit the chain around both sprockets bringing the free ends together on one sprocket as shown in Photo 33637. Insert connecting link and secure in place.

Note: Due to their flexibility, chains can be somewhat difficult to handle. When installing the chain, pick it up by the end links to avoid the possibility of pinching fingers or hands. Failure to do so may result in personal injury.

Chain tension Adjust drive centers for proper chain tension, as outlined below.

Normally, horizontal and inclined drives should be installed with an initial sag equal to approximately 2% of sprocket centers.

Vertical center drives, and those subject to shock loading, reversal of rotation, or dynamic braking, should be operated with both spans of chain almost taught. Periodic inspection of such drives should be made to avoid operation with excessive slack and to maintain proper chain tension.

To determine the amount of sag, pull one side of the chain taught allowing all the excess chain to accumulate in the opposite span. As illustrated in Photo 33638, place a straight edge over the slack span and, pulling the chain down at the center, measure the amount of sag. If necessary, adjust drive centers for proper sag that will result in correct chain tension.

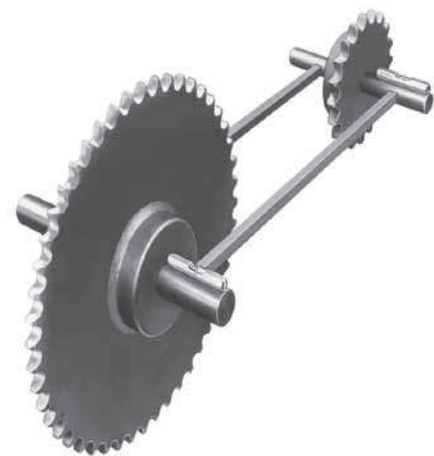

Aligning shafts

33635

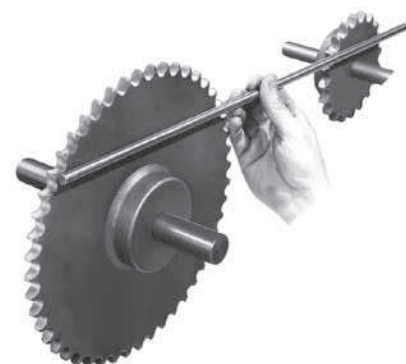

Aligning sprockets

33636



Inserting connecting link

33637



Determining chain sag

33638

Caution: To avoid serious personal injury, the drive should be enclosed in a casing or safety guard. Consult Rexnord for casing installation procedures. If the drive is not enclosed, clear the area of tools and other installation equipment before reconnecting the power.

Sag in inches based on 2% of sprocket centers											
Shaft centers, inches	20	30	40	50	60	70	80	90	100	125	150
Sag, Inches	.50	.63	.88	1.00	1.25	1.50	1.63	1.88	2.00	2.50	3.00

Sprockets

General Specifications

The standard sprockets used with Rexnord chains, both physical and dimensional, are based on sound engineering principles. They reflect the practical experience gained from applying drives over the last century.

Material and hardness

Sprocket materials and tooth hardness along with accurate machining, are as important to drive life as proper chain selection or adequate lubrication. Material and hardness have a strong influence on the rate of tooth wear and, therefore, the maintenance of optimum chain and sprocket interaction.

The severity and frequency of tooth loading, environment, and similar operating conditions form the basis for material selection. For example, the small sprocket is usually made of higher carbon, more wear-resistant steel because its teeth contact the chain more often than those on the large sprocket. The frequency of contact is in direct proportion to the speeds of the driving and driven shafts. With these and other operating conditions in mind, the following standards have been established.

Recommended Sprocket

Materials are indicated in the table below. Material and tooth hardness recommendations are based on chain speed, number of teeth, and operating conditions. When drives are designed for short-term operation, it may be desirable to specify a lower hardness than indicated in the table.



Chain speed FPM	Number of teeth	Recommended material and hardness	
		Normal operating conditions ▲	Severe operating conditions ■
Up to 600	25 or less	Medium carbon steel with an approximate hardness of 170 Brinell	Medium carbon steel with teeth hardened to 35C Rockwell minimum
	26 or more	Medium carbon steel with an approximate hardness of 170 Brinell; or cast iron with a minimum hardness of 183 Brinell	Medium carbon steel with teeth hardened to 35C Rockwell minimum; or Alloy cast iron
Over 600	25 or less	Medium carbon steel with teeth hardened to 35C Rockwell minimum	Medium carbon steel with teeth hardened to 35C Rockwell minimum
	26 or more	Medium carbon steel with an approximate hardness of 170 Brinell; or cast iron with a minimum hardness of 183 Brinell	Medium carbon steel with teeth hardened to 35C Rockwell minimum; or Alloy cast iron

▲ Operating conditions are considered normal when drives are enclosed and adequately lubricated, or when open drives operated in a clean atmosphere with ample lubrication.

■ Operating conditions are considered severe when drives are subject to frequent heavy overloads, shock or pulsating loads, inadequate lubrication, or when open running drives operate in an abrasive or corrosive atmosphere.