

# Instalaciones III



**UNCUYO**  
UNIVERSIDAD  
NACIONAL DE CUYO

## “Parlantes”

**Ing. Juan Bertrán**

*Ingeniero en Electrónica  
Especialista en Audio y Sonido*

**Mg. Ing. Adriano Sabez**

*Ingeniero en Acústica  
Mg. en Acústica Arquitectónica y Medioambiental*

# Parlantes

Imán



Imán

Bobina

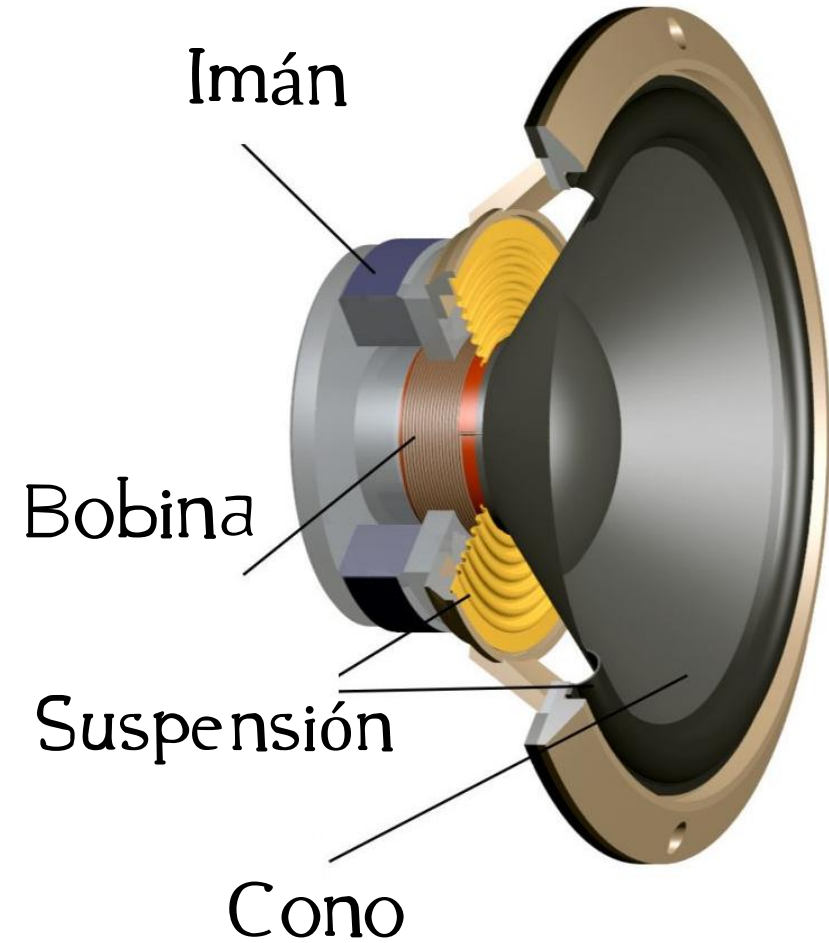

# Funcionamiento

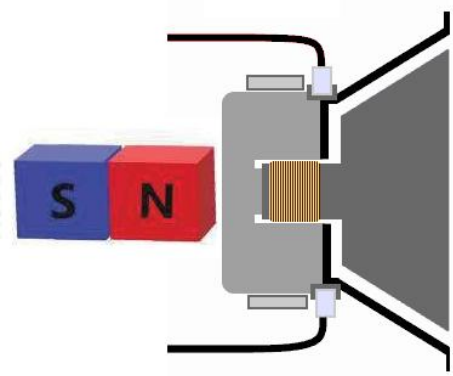

Sin Señal

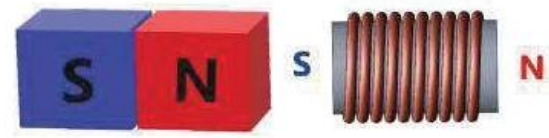
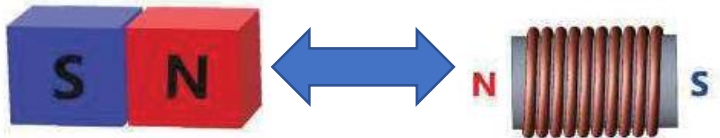
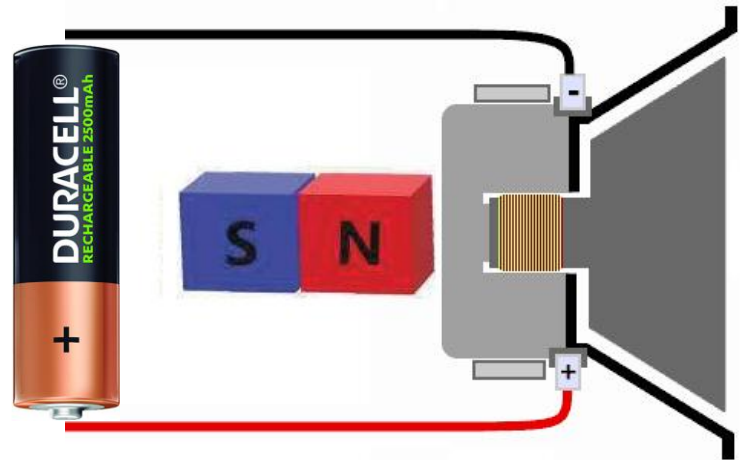
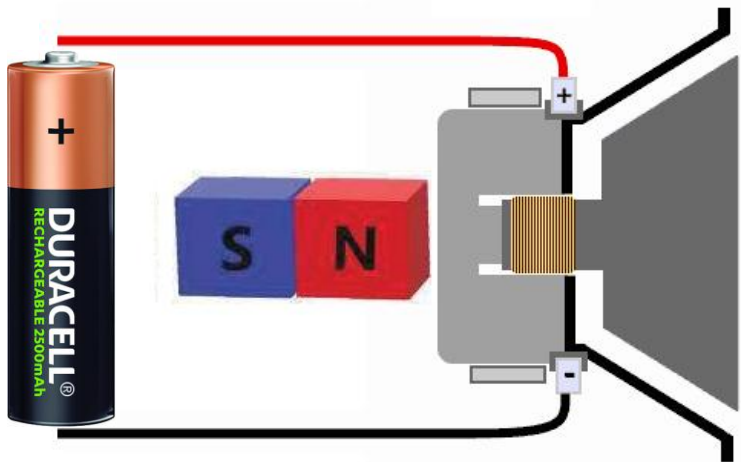

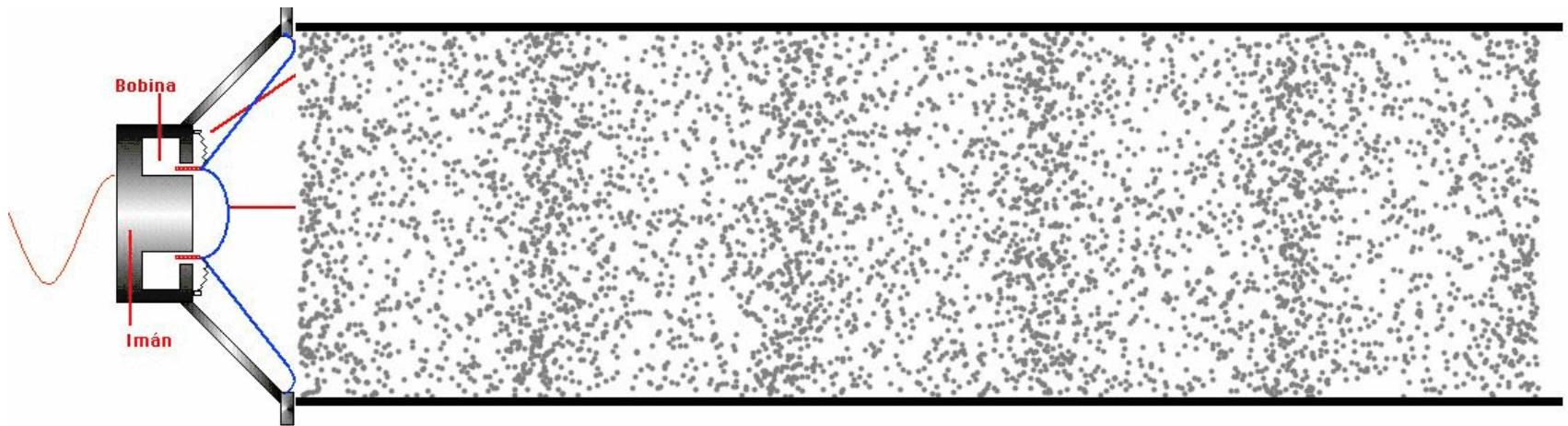

**How Speakers Work**

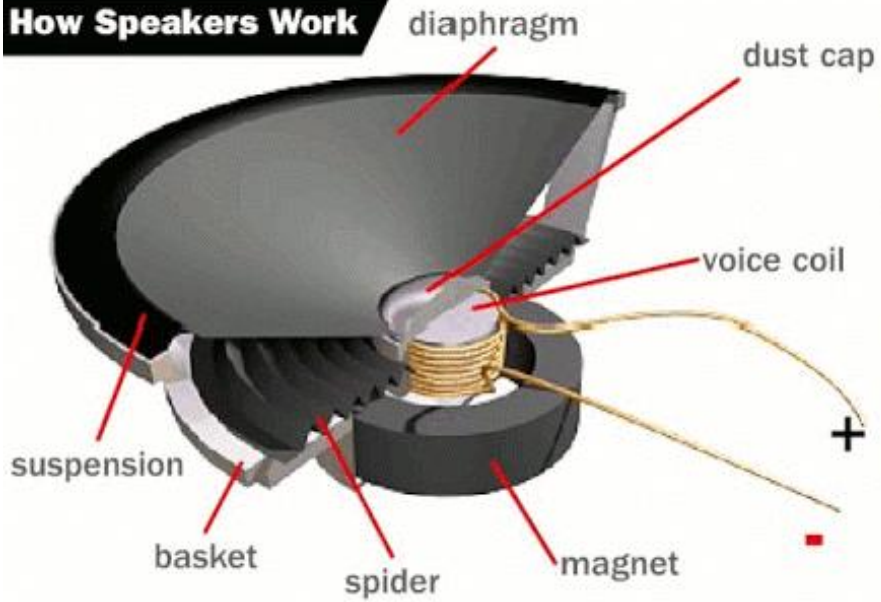

©2001 How Stuff Works

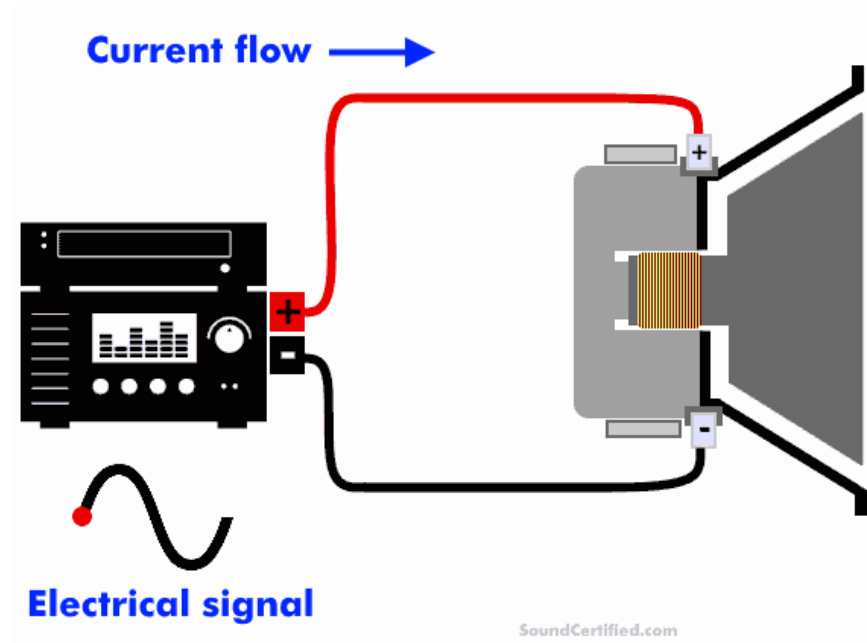

SoundCertified.com

# Características

Impedancia  
"Z"

4 Ohm

8 Ohm

16 Ohm

$$Z = R + X$$

Resistencia + Reactancia

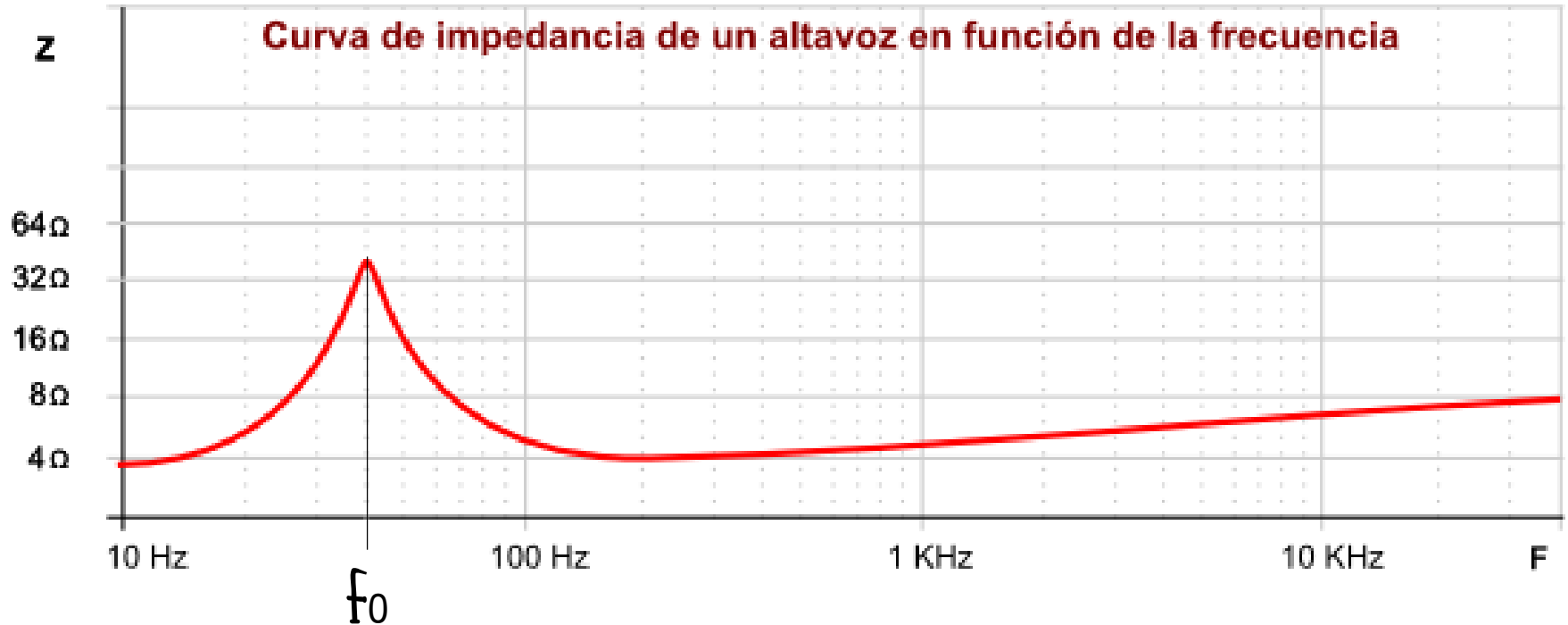
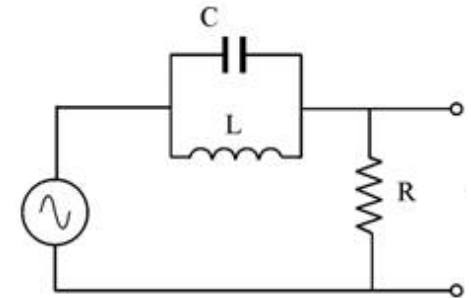
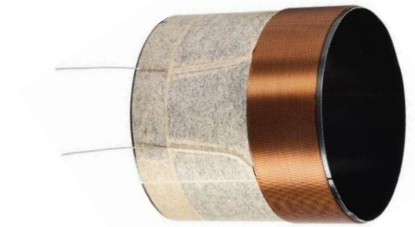

# Potencia y Sensibilidad



Es de 60  
Watts RMS,  
¡no sabes lo  
que suena!



No, no sé  
lo que  
suena....

Watts RMS es  
la potencia  
ELÉCTRICA  
que SOPORTA  
un parlante  
antes de  
quemarse



## Sensibilidad



Capacidad de un parlante de  
transformar  
**POTENCIA ELECTRICA**  
en  
**INTENSIDAD SONORA**

*dB con  $1W_{rms}$  a 1metro*

# Respuesta en Frecuencia – Parlantes para Graves



B&C 15HPL76w

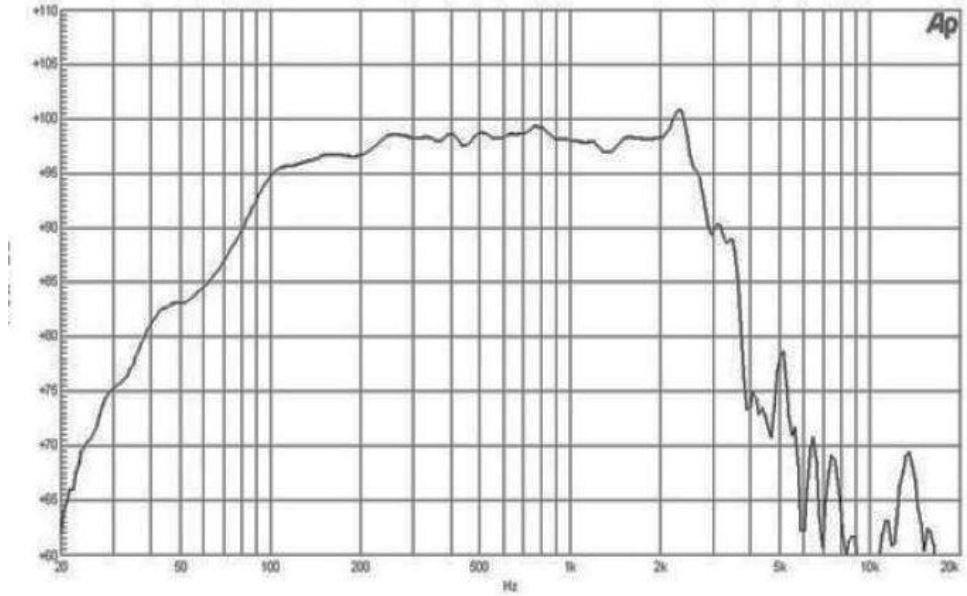

4 Ohm

350W

99dB



Selenium 15PW6

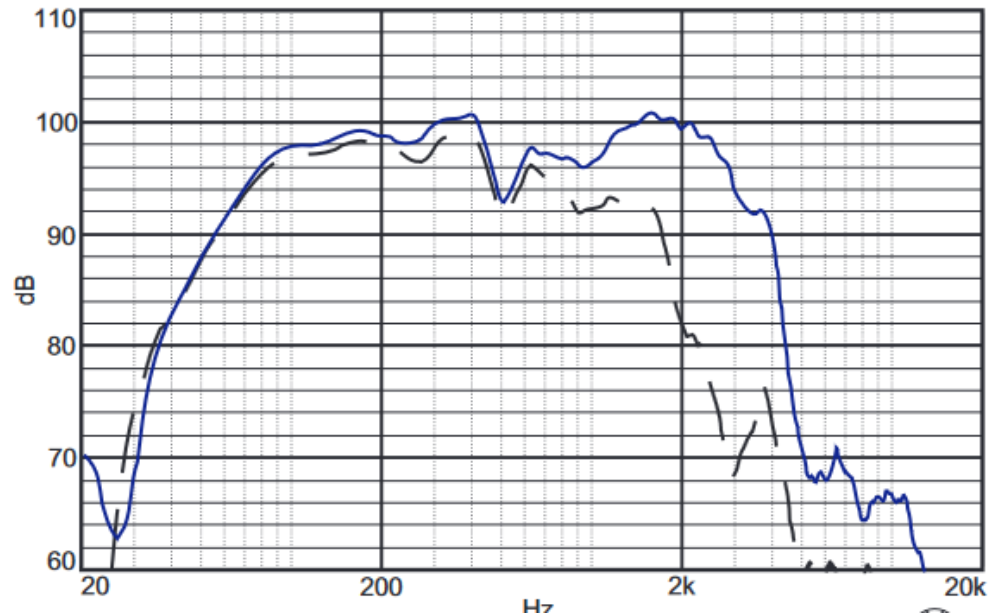

8 Ohm

400W

97dB

# Respuesta en Frecuencia – Parlantes para Medios



Jensen 12-70

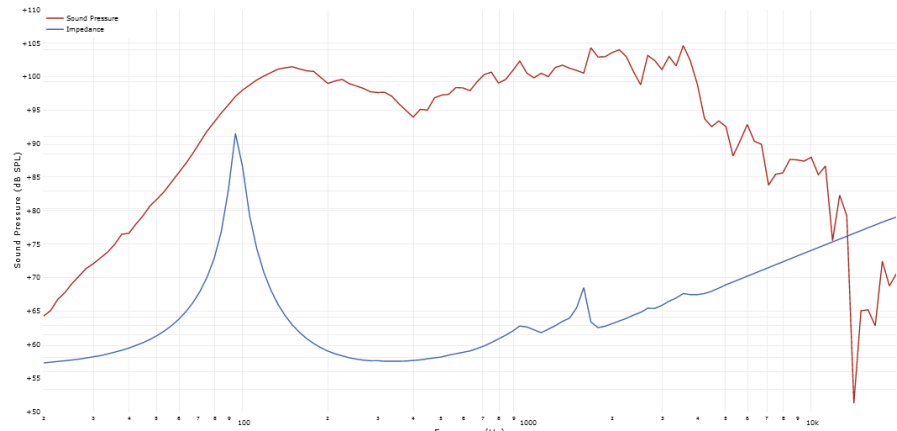

8 Ohm

70W

97dB



Eminence Beta 10  
CBMRA

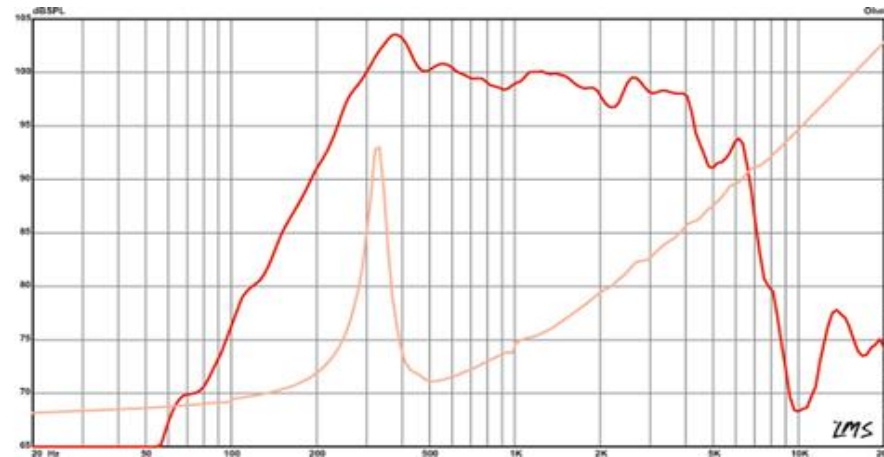

8 Ohm

200W

99.6dB



# Respuesta en Frecuencia – Parlantes “drivers” para Agudos



JBL D202TI

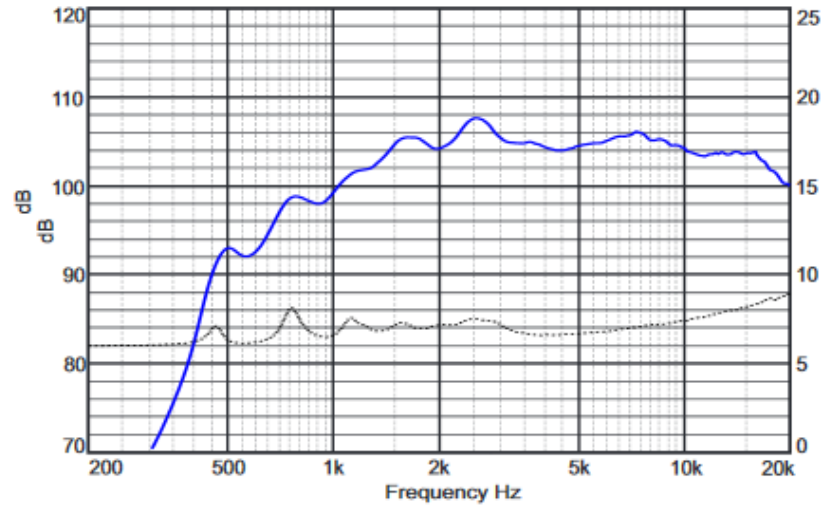

8 Ohm

60W

106dB



D.A.S K-8

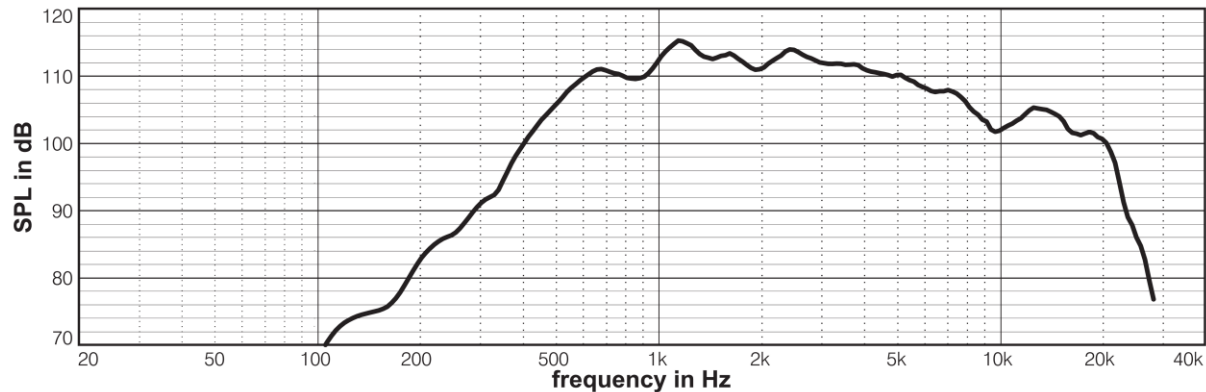

16 Ohm

125W

110dB

# Cornetas para Drivers



# ¿Cuánto sonará un parlante?

8 Ohm, 400W y 97dB



amplificador  
de potencia

$$1W \rightarrow 97dB \quad L_{[SPL]} = 10 \log \frac{400W}{1W} = 26dB$$

Máximo  
Volumen

$$\rightarrow 97dB + 26dB = \boxed{123dB}$$

$400 W_{RMS}$

8 Ohm, 200W y 99.6dB

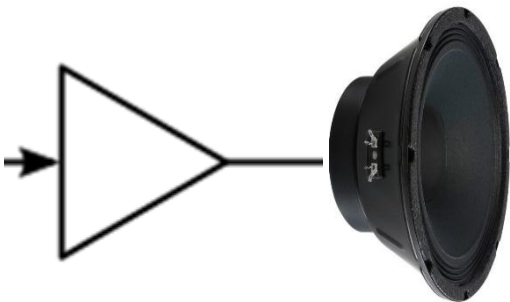

amplificador  
de potencia

$$1W \rightarrow 99.6dB \quad L_{[SPL]} = 10 \log \frac{200W}{1W} = 23dB$$

Máximo  
Volumen

$$\rightarrow 99.6dB + 23dB = \boxed{122,6dB}$$

$400 W_{RMS}$

# ¿Cuánto sonará un parlante?

8 Ohm, 400W y 97dB



$$1W \rightarrow 97dB \quad L_{[SPL]} = 10 \log \frac{5W}{1W} = 7dB$$

Máximo  
Volumen

$$\rightarrow 97dB + 7dB = \boxed{104dB}$$

$5 W_{RMS}$

# Gabinete Acústico o "Baffle"

## Cortocircuito Acústico

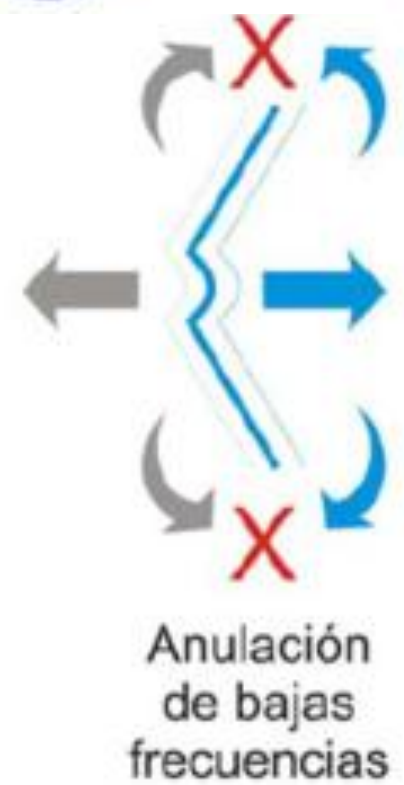
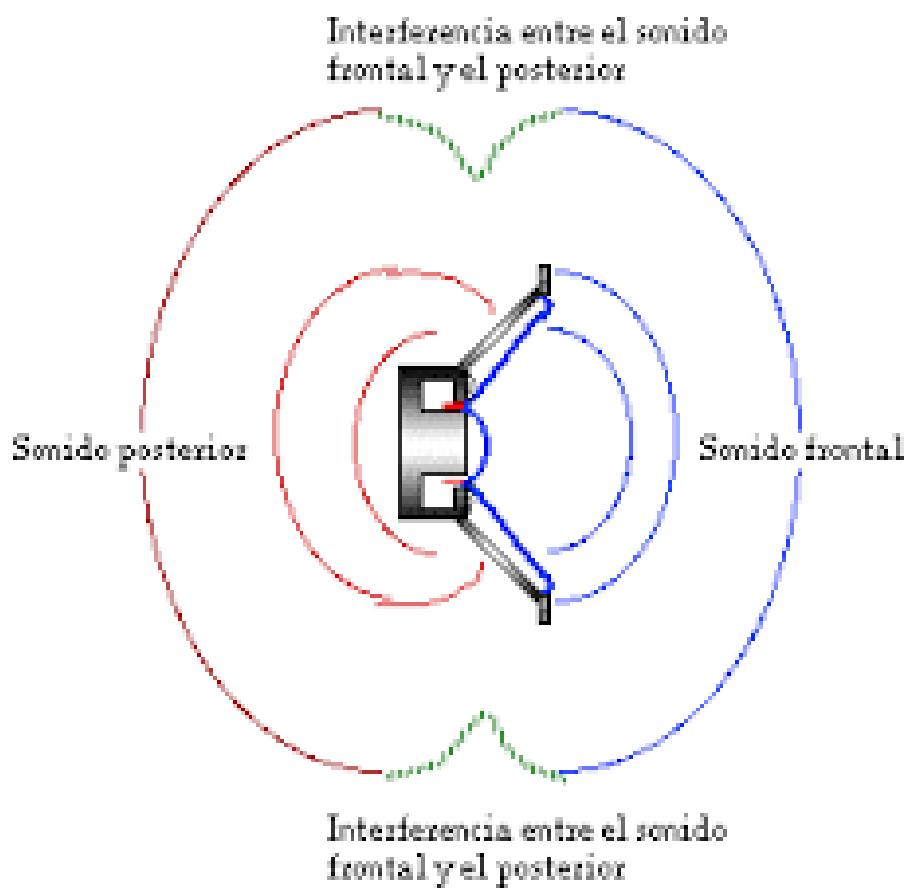
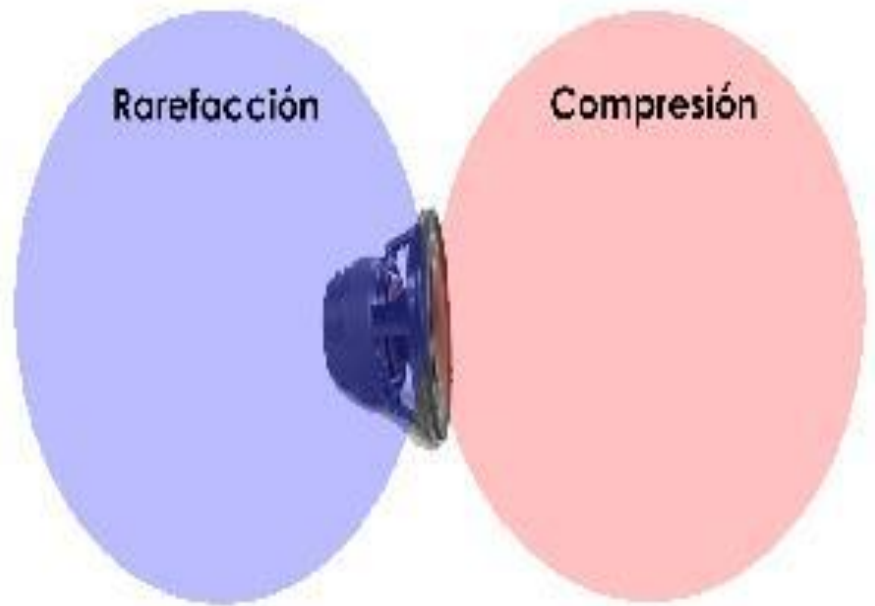

# Gabinete Acústico Cerrado o “Bafle infinito”

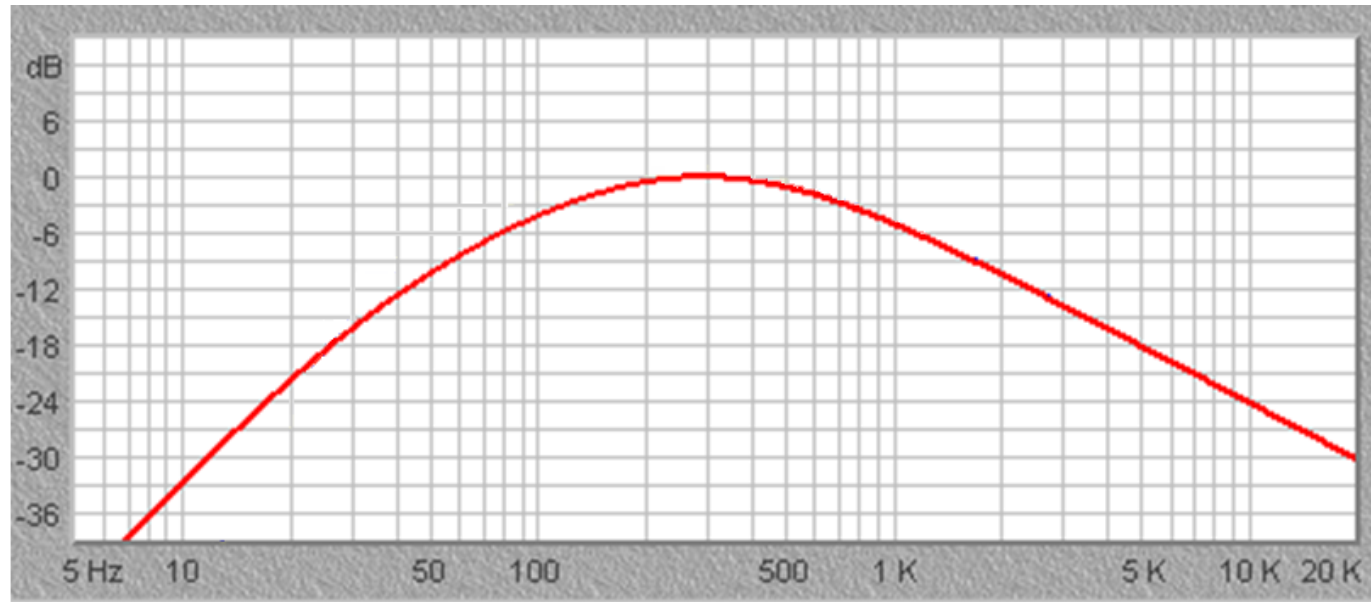
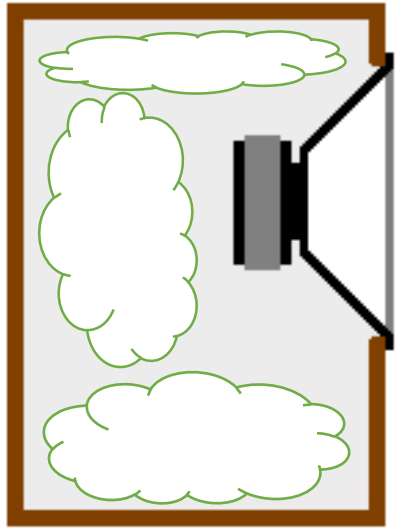

- Caja hermética
- Rellena o no con material absorbente
- Parlantes con suspensión muy blanda

# Gabinete Acústico ventilado o “Bass Reflex”

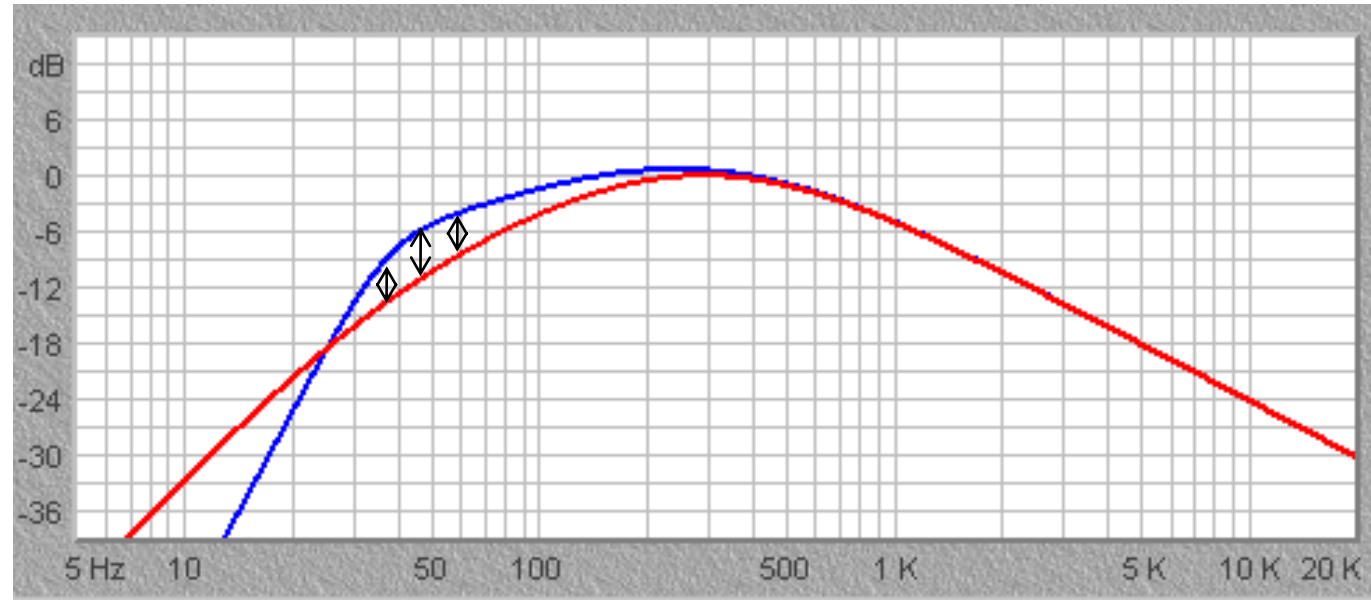
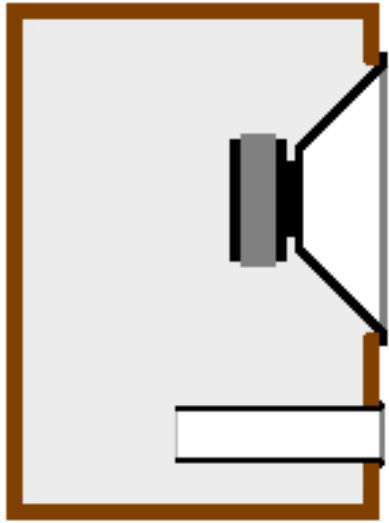

- Ganancia de 6db en bajas frecuencias
- Sin material absorbente
- Mejora el Rendimiento del parlante

# ¿Cómo funciona un Gabinete Bass Réflex?

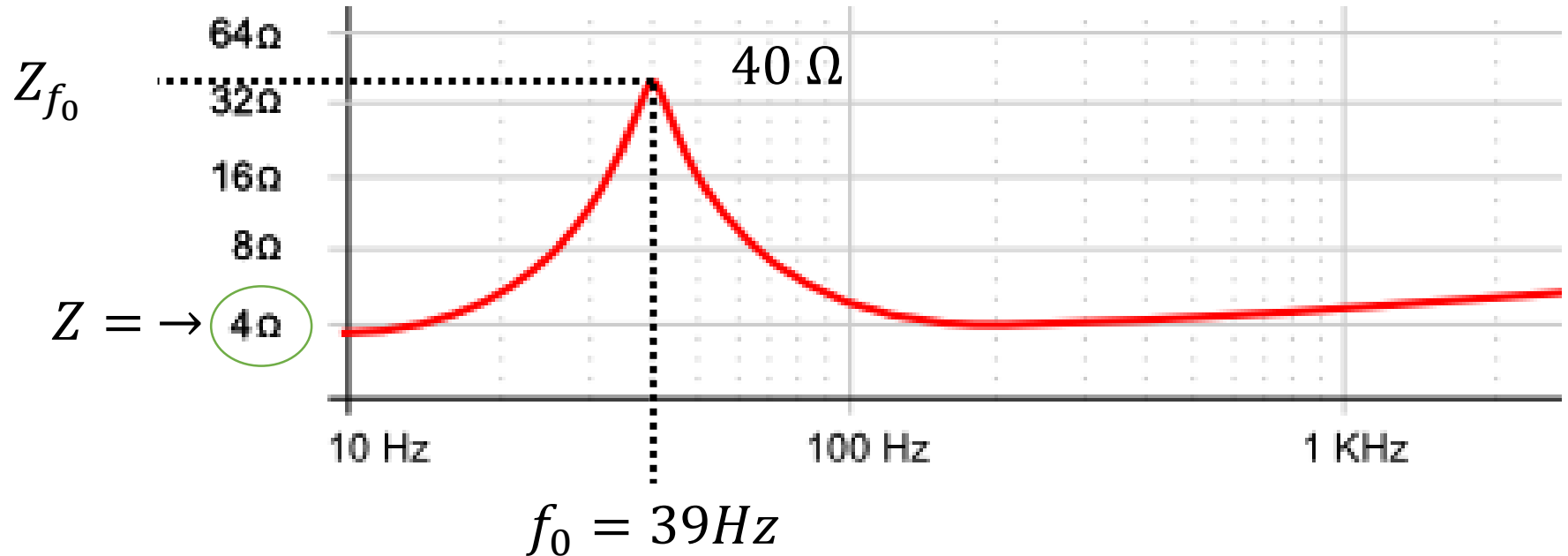

$$P = \frac{(V_{RMS})^2}{40 \Omega} = W_{RMS}$$

*En  $f_0$  el parlante recibirá  
10 veces menos potencia  
del amplificador*



# Tubos de Sintonía

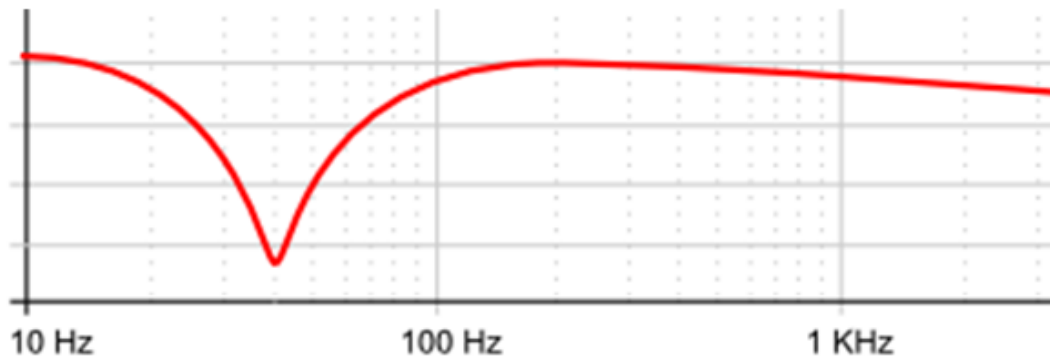
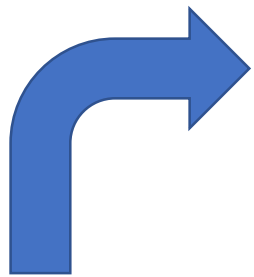
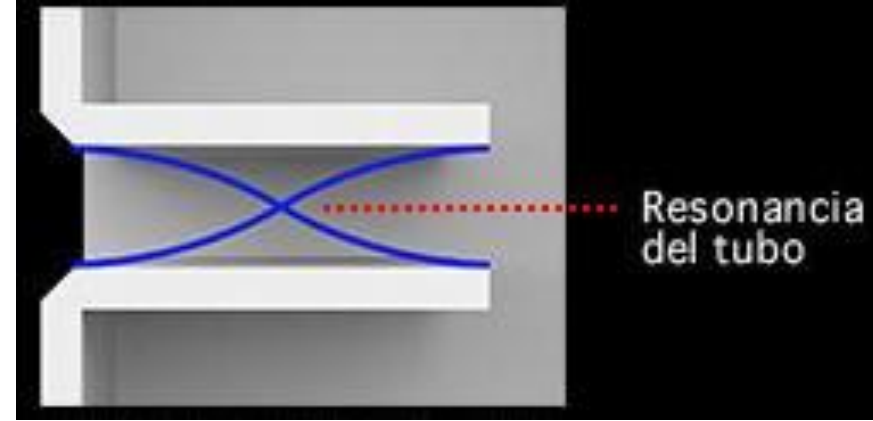

Sintonizamos el gabinete para que resuene a la misma frecuencia que el parlante

BAFLE

# Parlante dentro de Gabinete Sintonizado

Impedancia del parlante

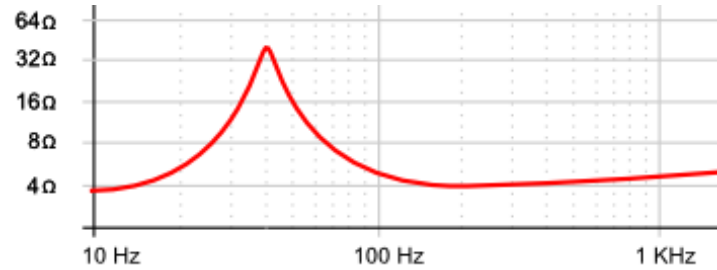

Impedancia del gabinete

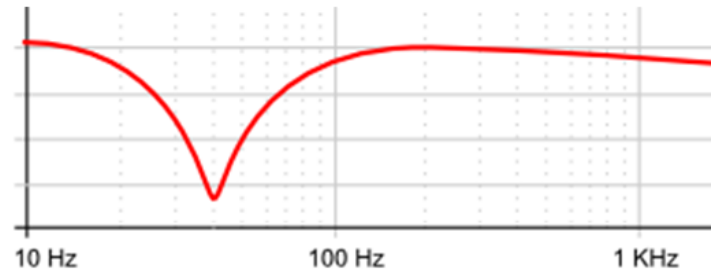

System Impedance (ohms/Hz)

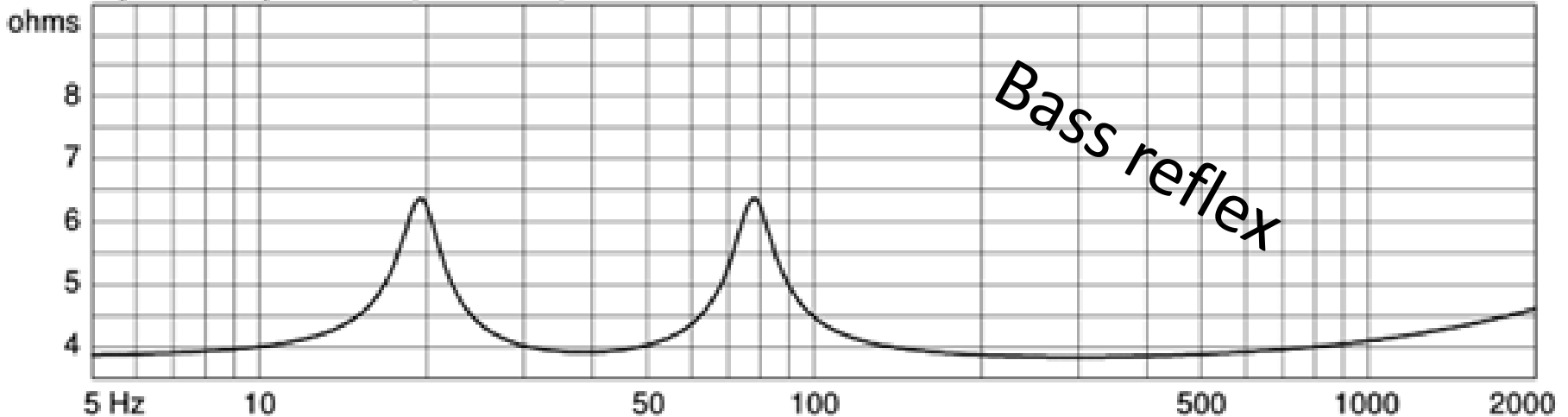

# Interconexión de Parlantes

## Conexión Serie

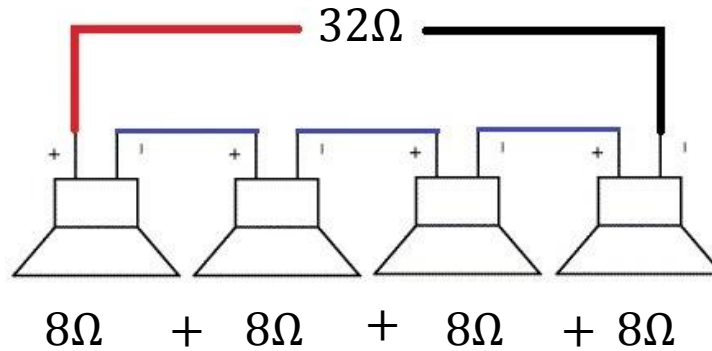

$$Z = Z_1 + Z_2 + Z_3 + Z_4$$

$$Z = 8 + 8 + 8 + 8 = 32$$

## Conexión Paralelo

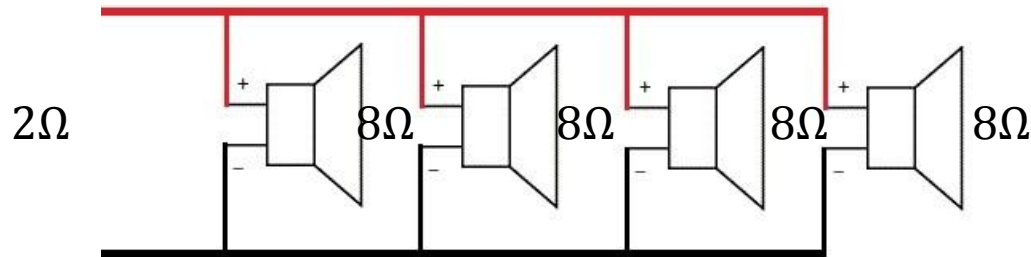

$$Z = \frac{1}{\frac{1}{Z_1} + \frac{1}{Z_2} + \frac{1}{Z_3} + \frac{1}{Z_4}}$$

$$Z = \frac{1}{\frac{1}{8} + \frac{1}{8} + \frac{1}{8} + \frac{1}{8}} = 2$$

## Conexión Mixta

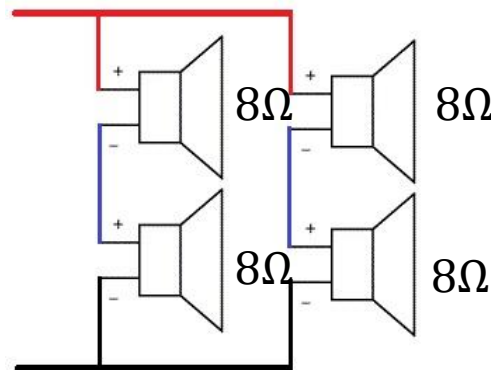

$$Z_{serie} = 8 + 8 = 16$$

$$Z_{paralelo} = \frac{1}{\frac{1}{16} + \frac{1}{16}} = 8$$

$$Z = 8$$

# Conexión de parlantes con transformador

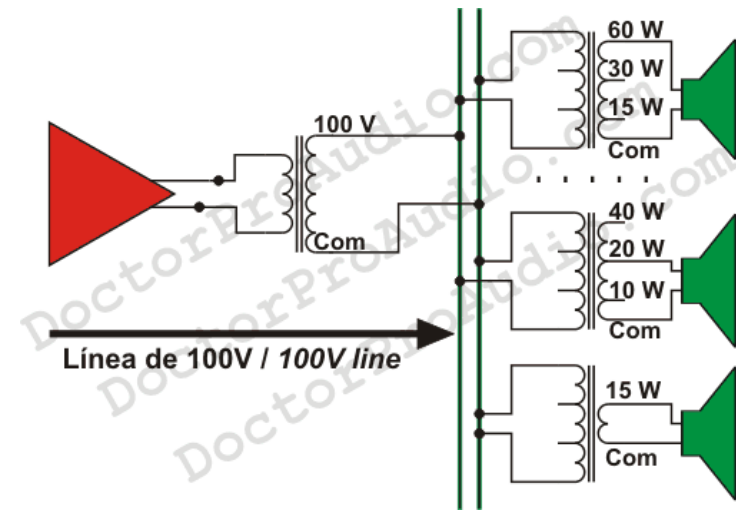
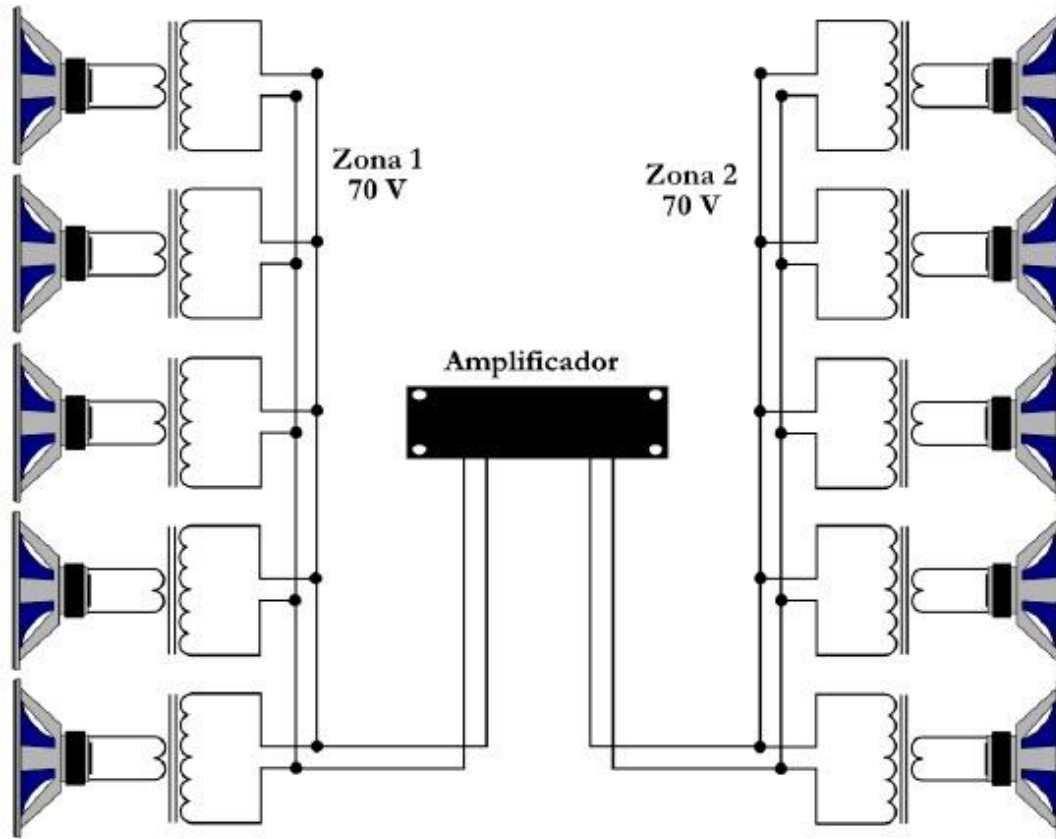

# Parlantes para diseño arquitectónico

Parlantes para embutir en techos

Modelo abierto



# Parlantes para embutir en techos

## Bass-Reflex



Control Series

8 ohm  
30 watts RMS  
87dB

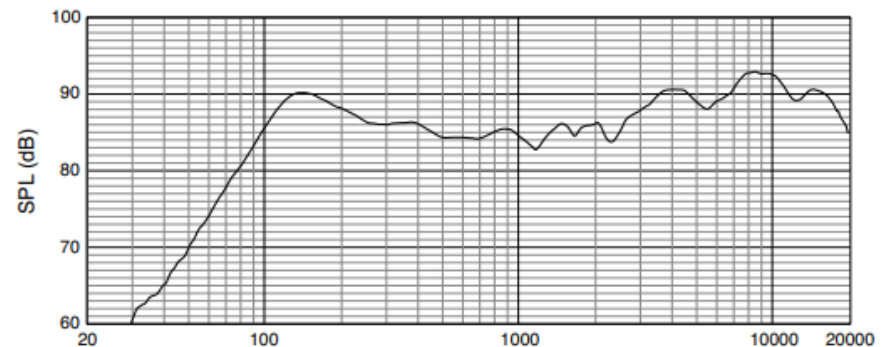
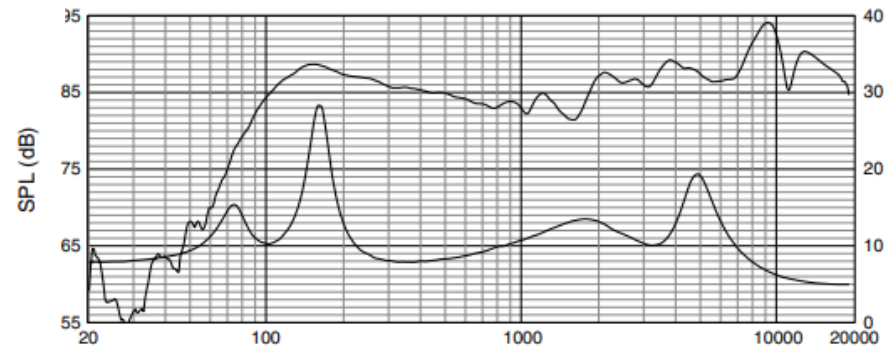

# Parlantes para muros

Con gabinete cerrado

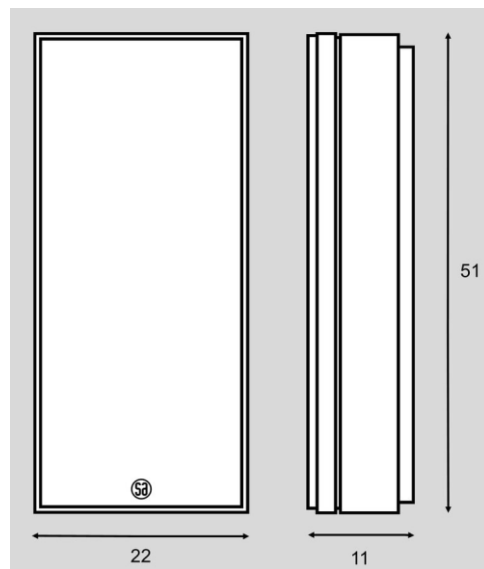

SA Saxo16

SIN DATOS

# Parlantes para embutir en muros

## Modelo abierto



In-Wall Series

SIN DATOS

**SONOS**



# Parlantes para embutir en muros

## Gabinete cerrado Bass Reflex

### SONANCE



Invisible Series

5 ohm  
100 watts RMS  
90dB

# Parlantes para exteriores “clásicos”



# Parlantes para exteriores “modernos”

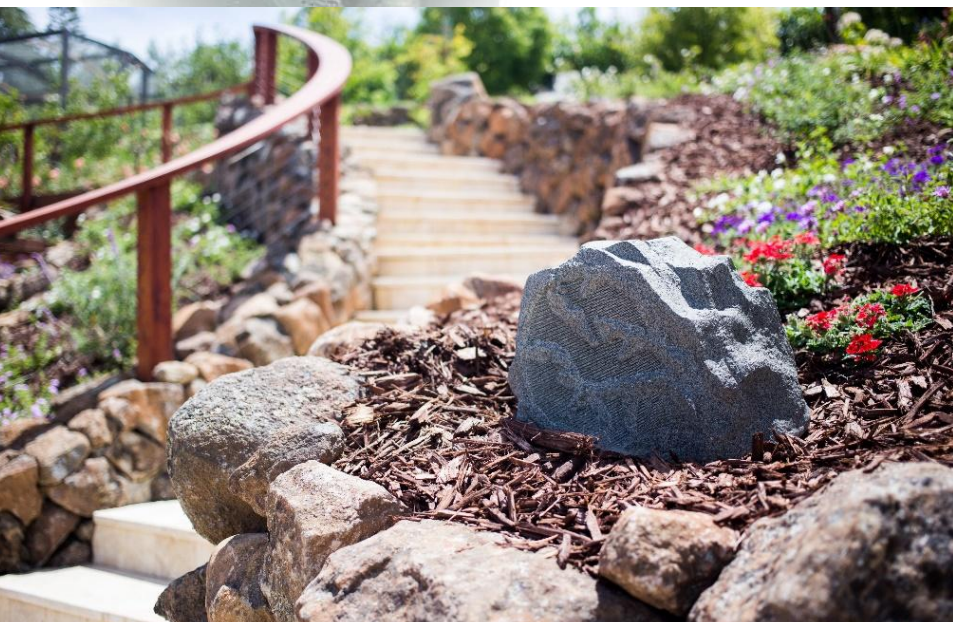
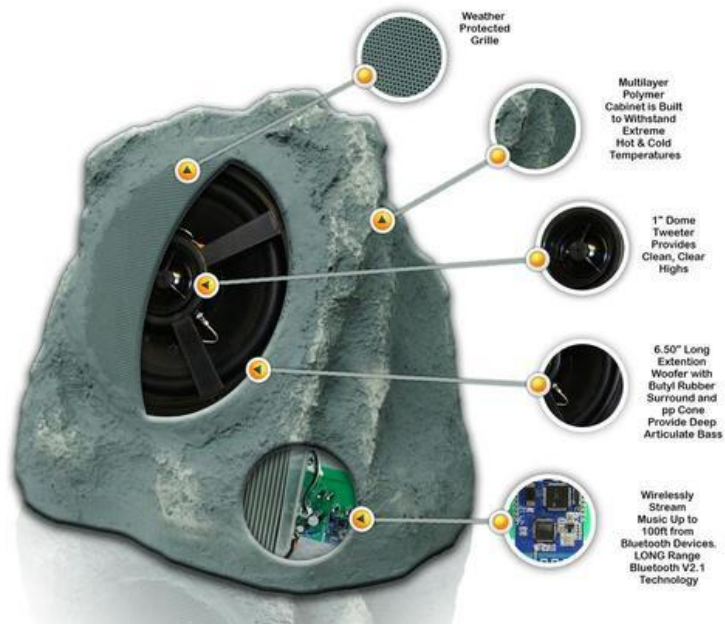

# Parlantes para exteriores “modernos”



BLINDADOS



# AUDIO FREQUENCY SPECTRUM

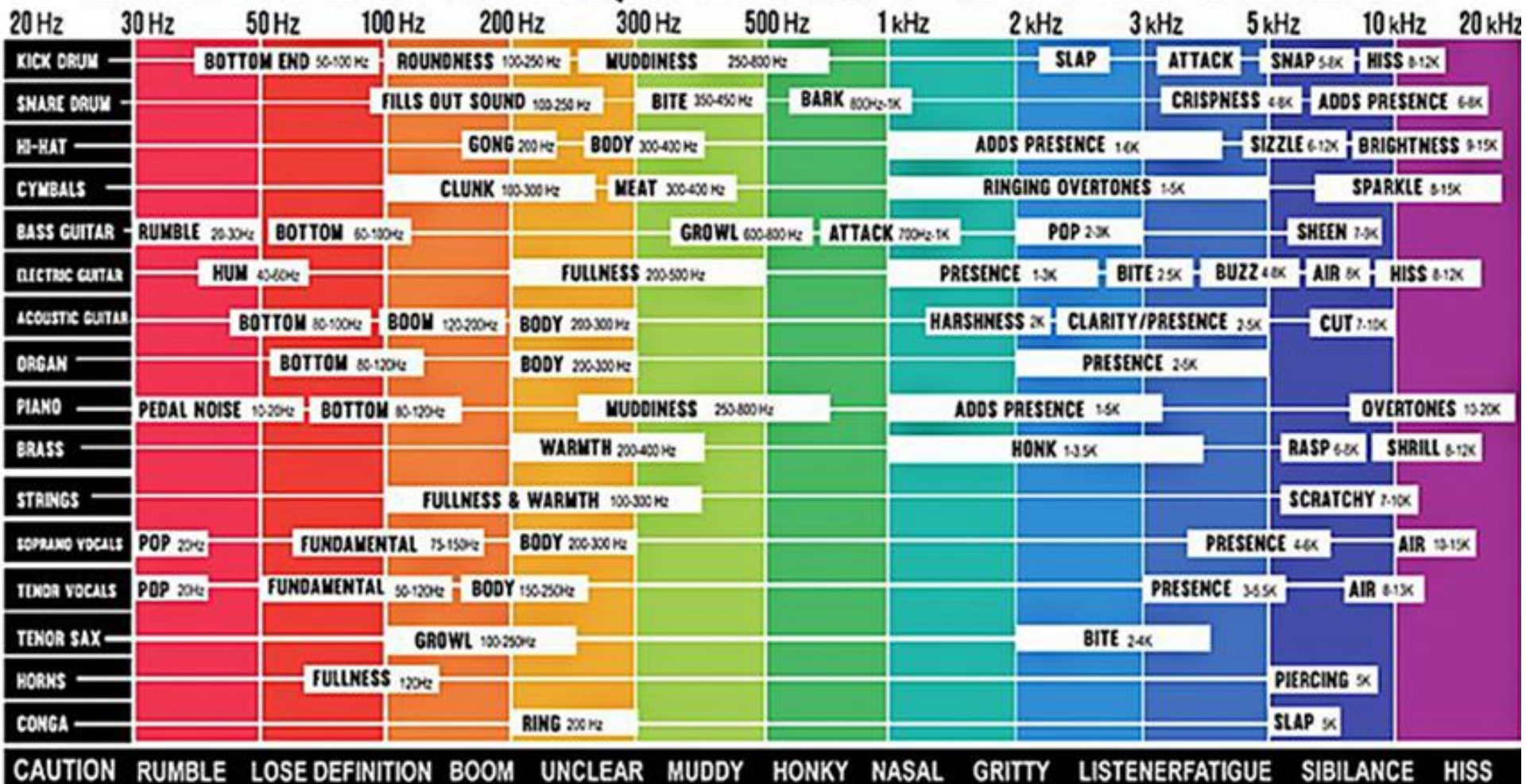

CAUTION RUMBLE LOSE DEFINITION BOOM UNCLEAR MUDDY HONKY NASAL GRITTY LISTENER FATIGUE SIBILANCE HISS