



DISEÑO ESTRUCTURAL III

DISEÑO SISMORRESISTENTE

DIAFRAGMAS

JUNTAS Y COLINDANCIA



Contenido

- **Reacción del edificio**
- **Distribución de acciones en Diafragmas Rígidos**
- **Distribución de acciones en Diafragmas Flexibles**
- **Aberturas en Diafragmas**
- **Formas irregulares**
- **Juntas y Separaciones de Colindancia**



REACCIÓN DEL EDIFICIO



REACCIÓN DEL EDIFICIO

SISTEMAS RESISTENTES

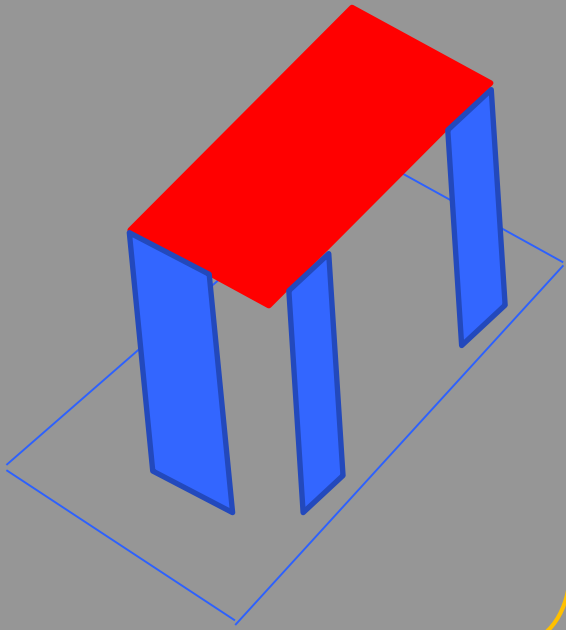

Planos Verticales

- Tabiques
- Pórticos (Masa)
- Triangulaciones (Vector)
- DUALES

Planos Horizontales

- Macizos (Masa)
- Triangulaciones (Vector)
- Plegados (Superficie)

Diafragmas





DISTRIBUCIÓN DE FUERZAS

DISTRIBUCIÓN DE FUERZAS SÍSMICAS EN PLANTA

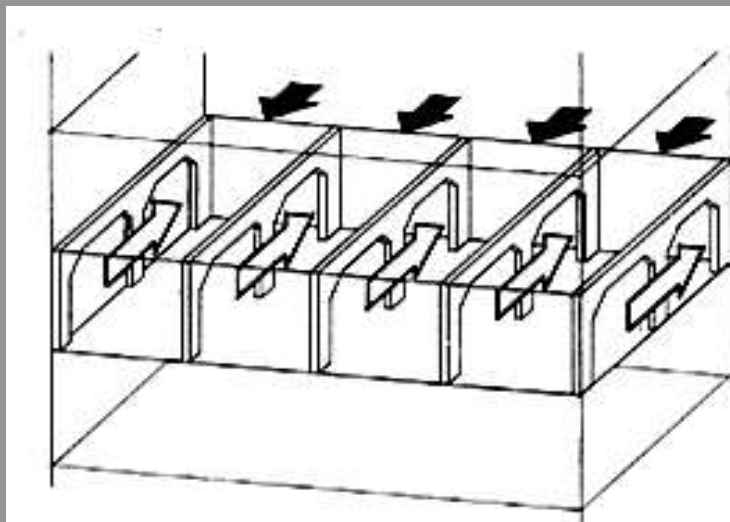

Diafragma Flexible

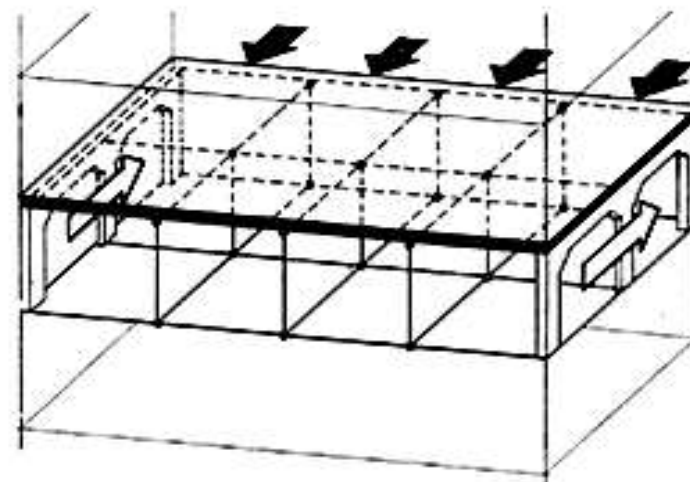

Diafragma rígido

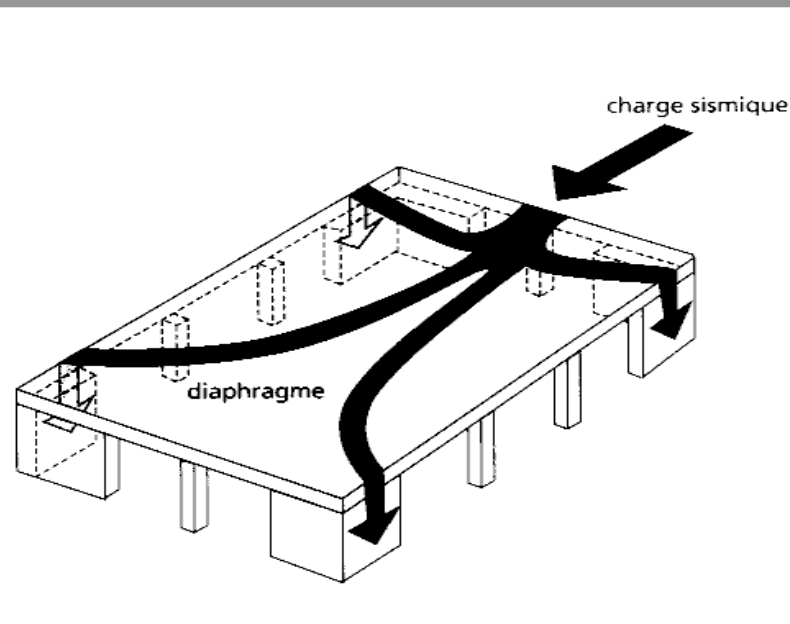
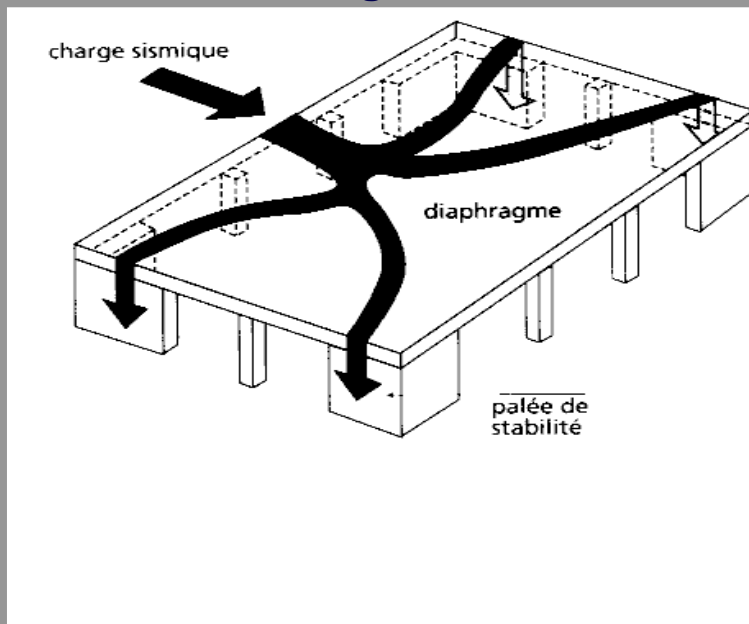

Transmisión de acciones sísmicas por diafragmas

DISTRIBUCIÓN DE FUERZAS SÍSMICAS EN PLANTA

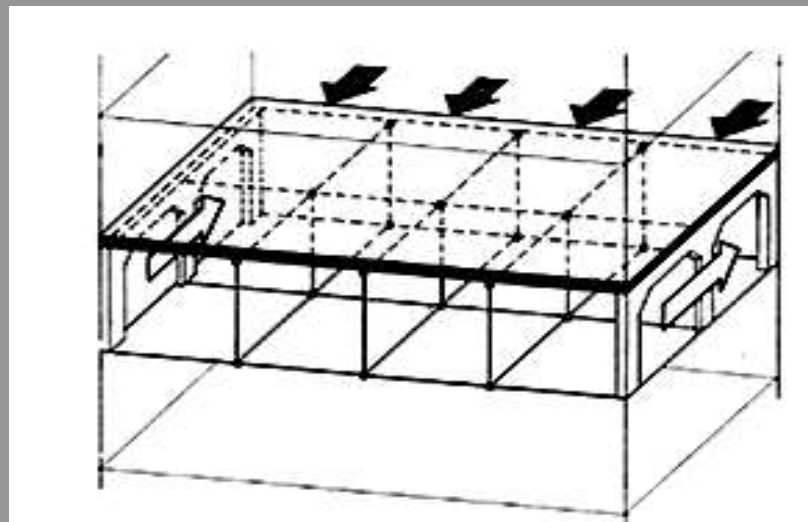

Diafragma rígido y pórticos

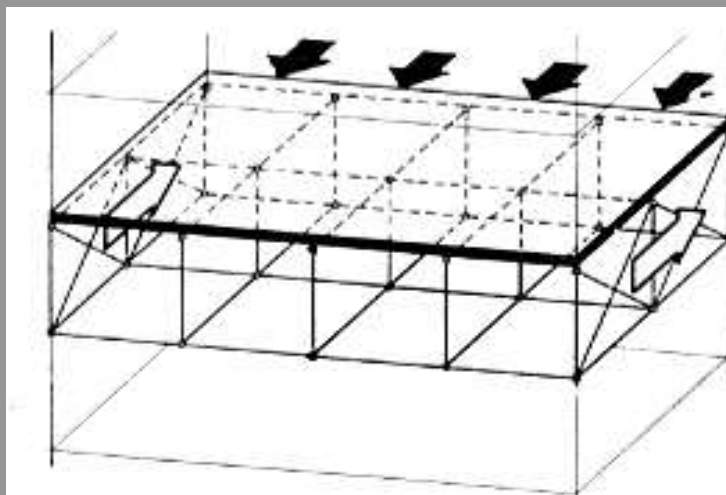

Diafragma rígido y triangulaciones

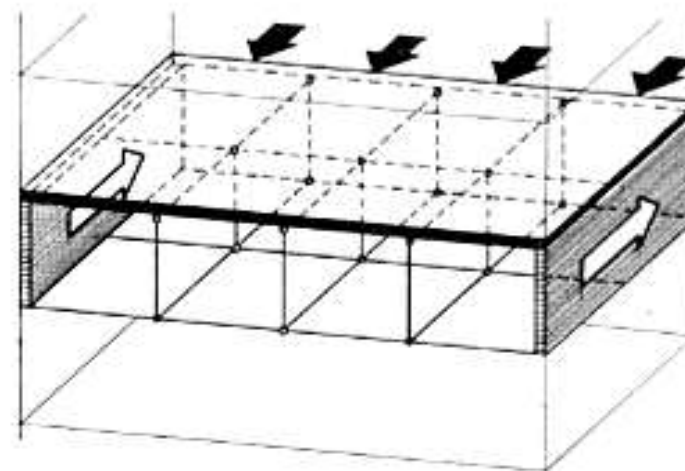

Diafragma rígido y muros

DISTRIBUCIÓN DE FUERZAS SÍSMICAS EN PLANTA

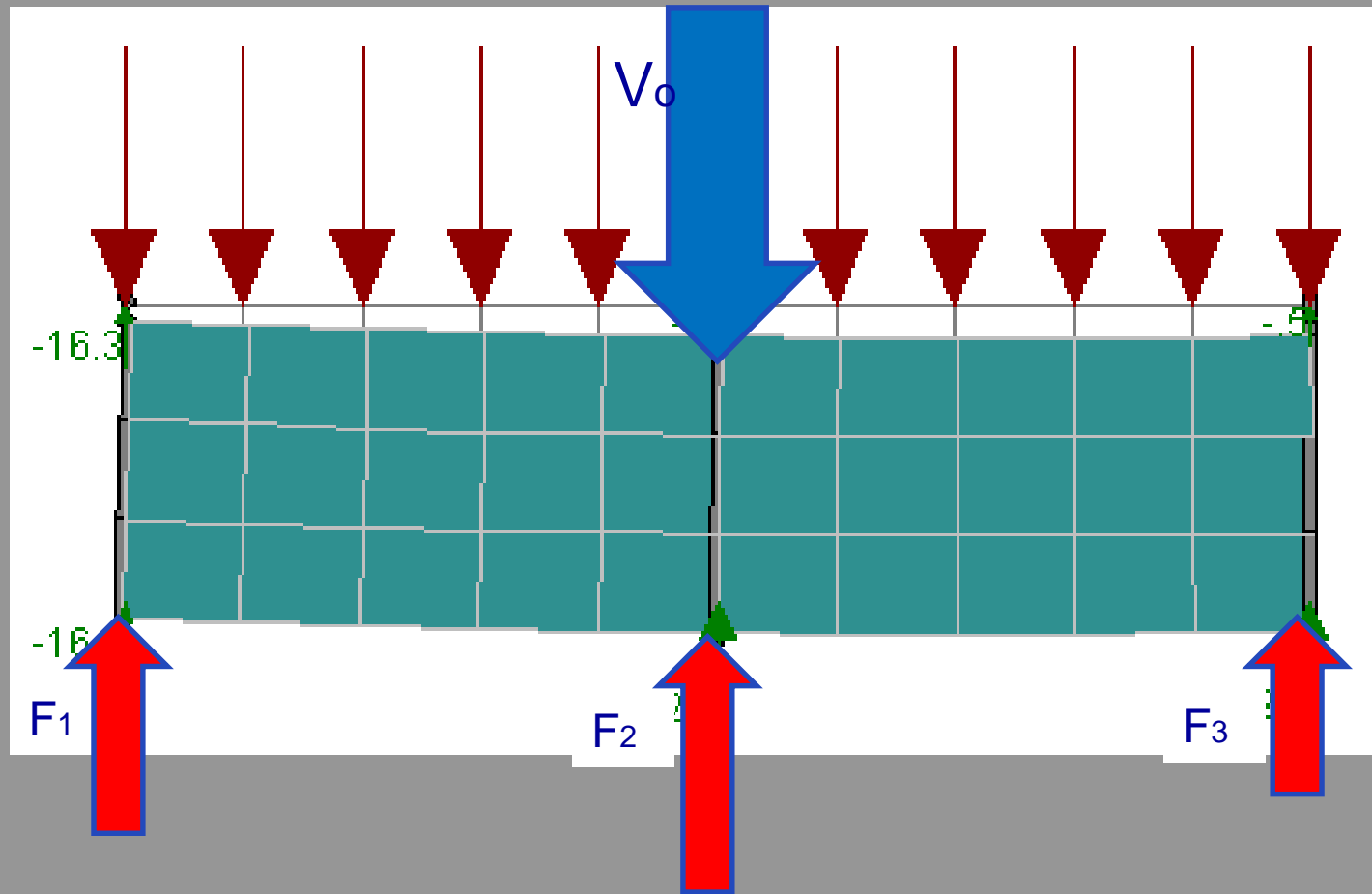

Diafragma **Rígido**

→ Distribución Fuerzas Sísmicas s/Rigidez Relativa

Si Excentricidad $< 5\%$

→ Distribución Simplificada por **Áreas Transversales**

(Nota: usando medios gráficos)

DISTRIBUCIÓN DE FUERZAS SÍSMICAS EN PLANTA

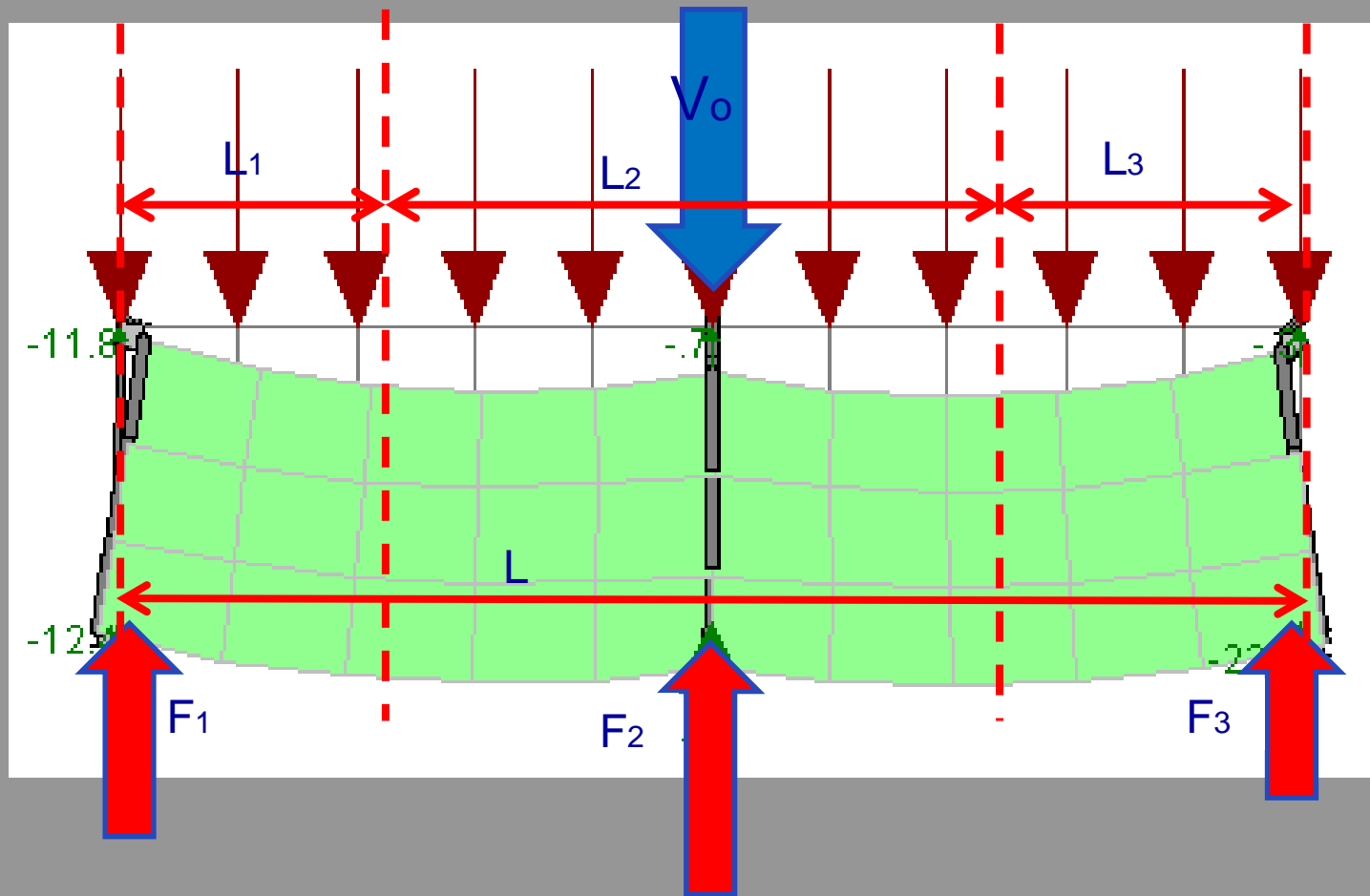

Diafragma **Flexible** → Distribución de Fuerzas Sísmicas por Ancho Tributario

$$F_1 = (L_1/L) V_o ; \quad F_2 = (L_2/L) V_o ; \quad F_3 = (L_3/L) V_o$$



DIAFRAGMAS Y JUNTAS

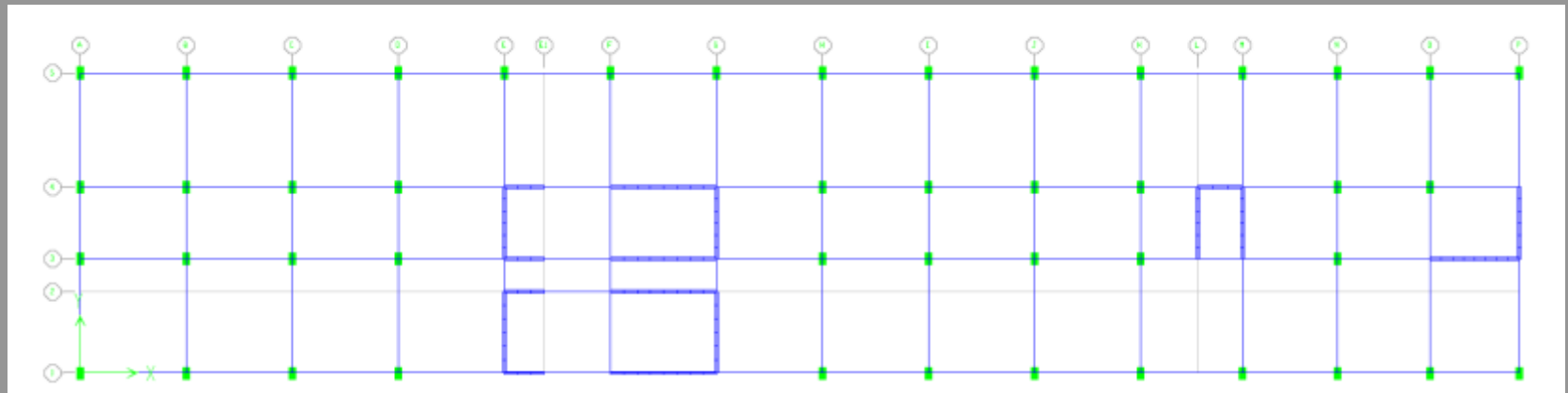
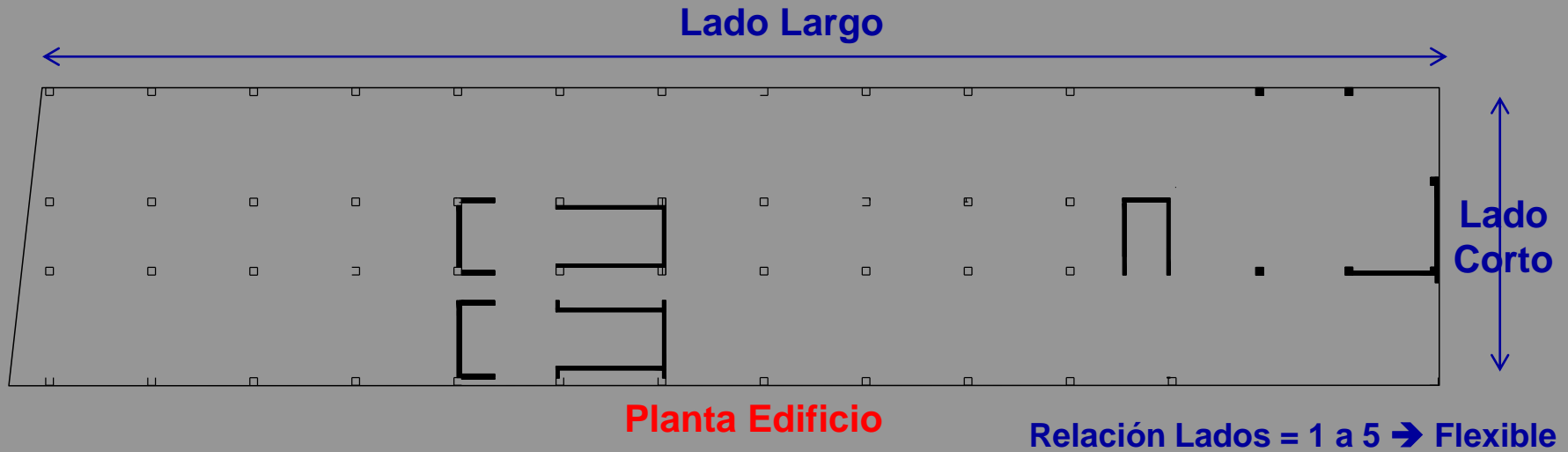

Modelo Estructural

DIAFRAGMAS Y COLINDANCIA

FLEXIBILIDAD Y RIGIDEZ

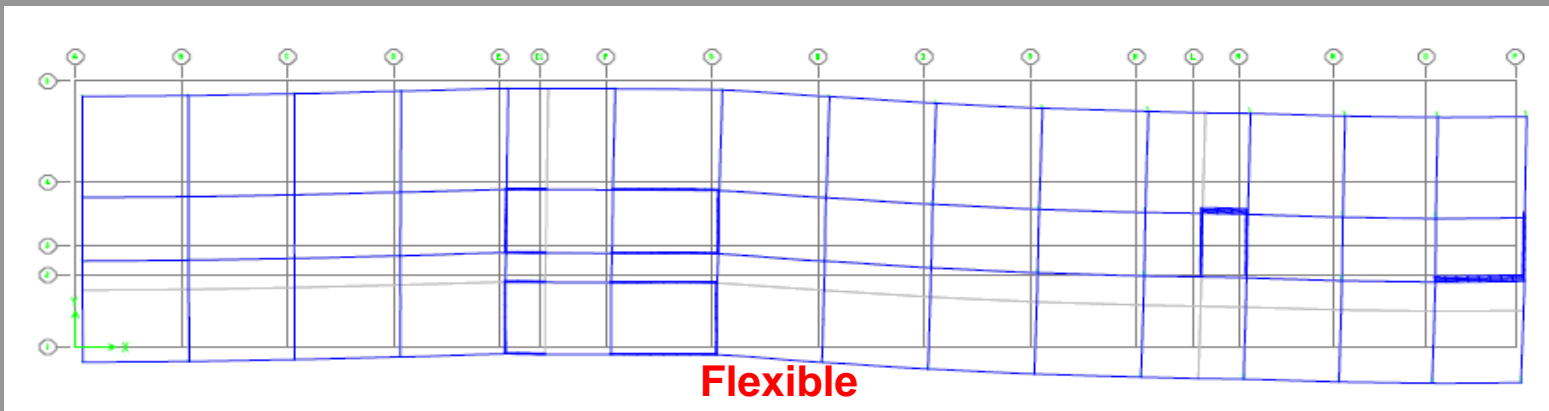
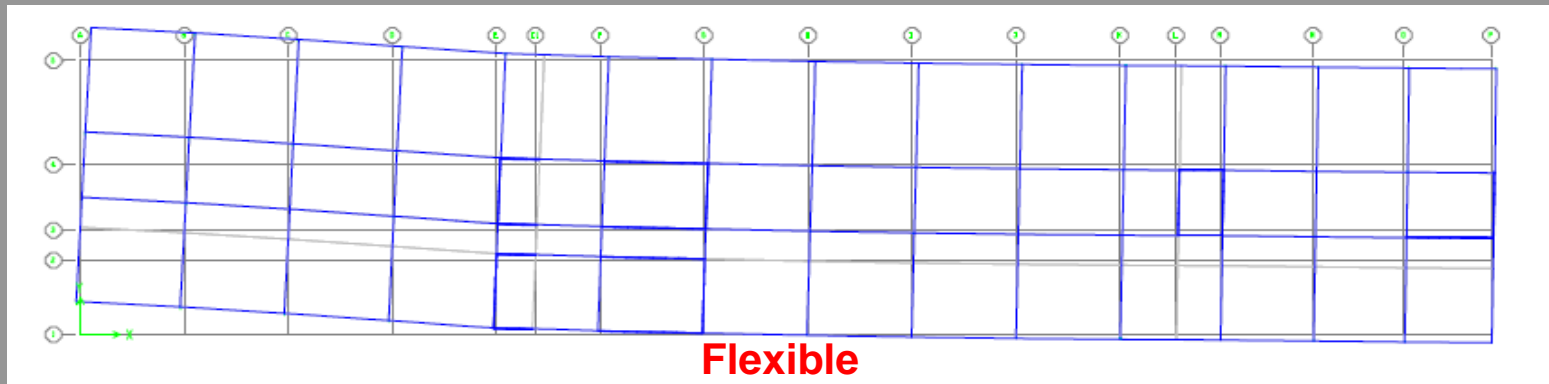
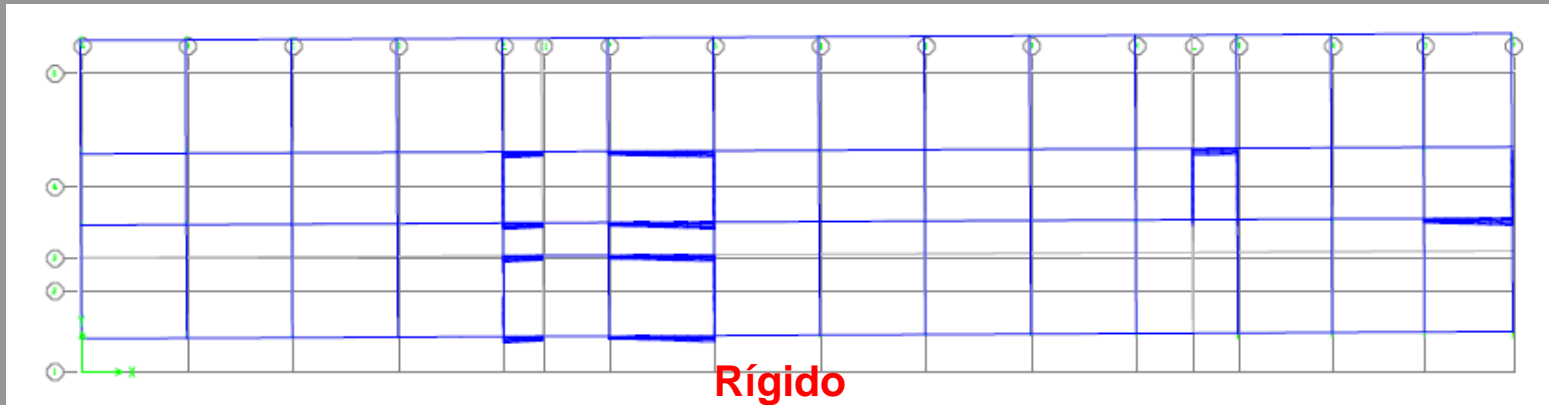



DIAFRAGMAS Y JUNTAS

Lado Largo

Relación Lados = 1 a 5 → Flexible

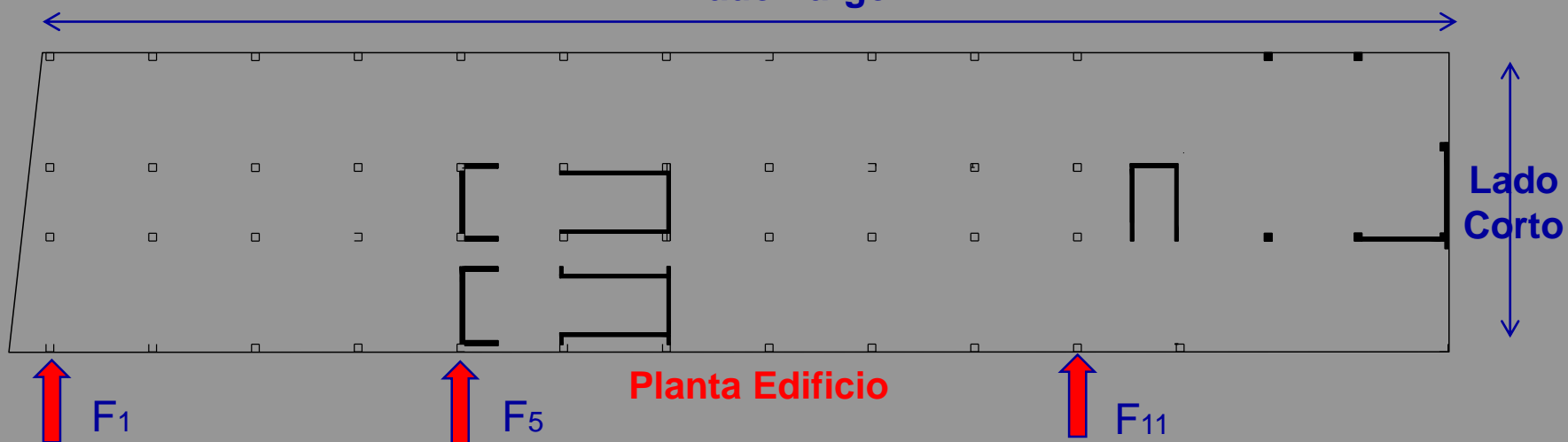

Rígido o Flexible?

AT planta= 2580 m²

AT estructura= 33 m²

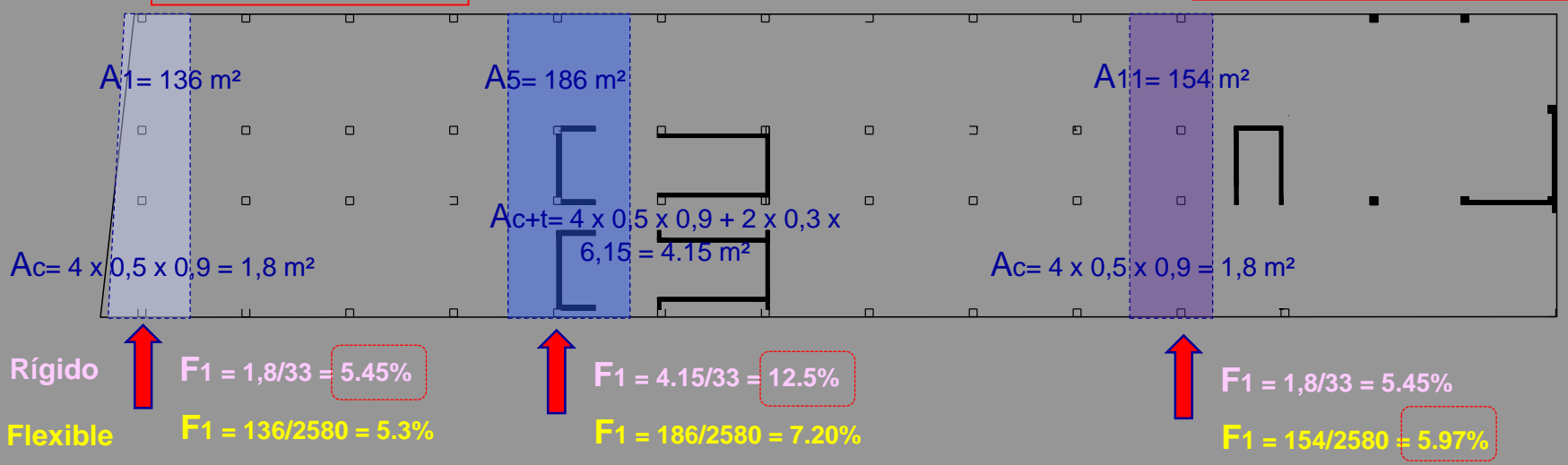



DIAFRAGMAS Y MASAS ASOCIADAS



Escuela Cariaco. Venezuela



Sillas y bancos salvadores



Sillas y bancos salvadores



Triángulo de la vida?



ABERTURAS EN DIAFRAGMAS



DIAFRAGMAS

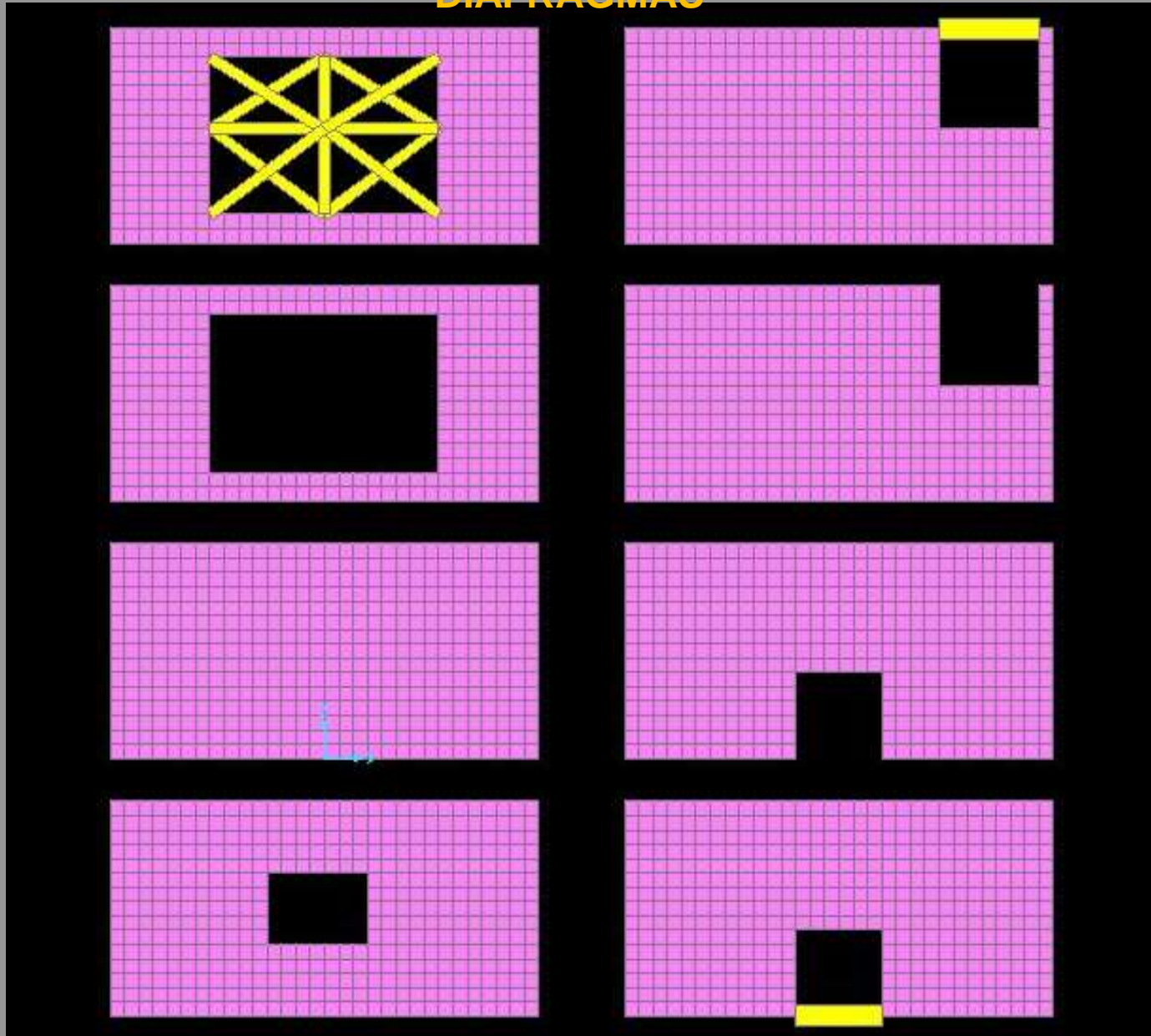



DIAFRAGMAS

Analysis Model

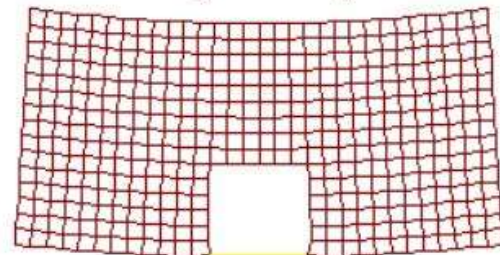
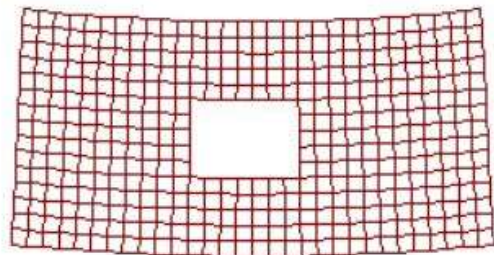
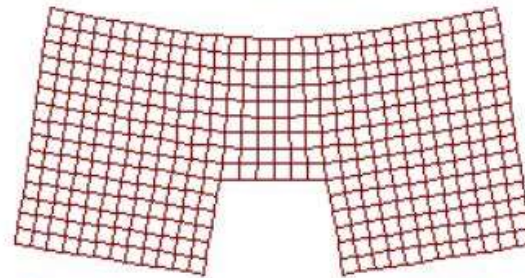
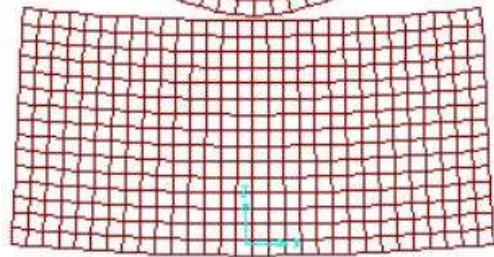
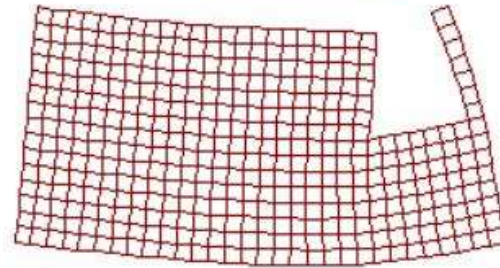
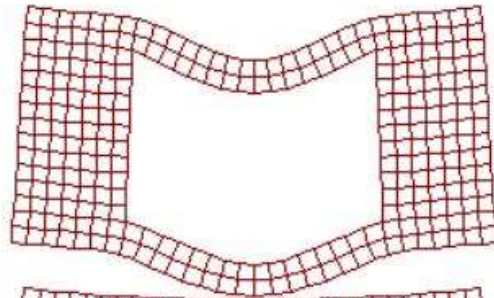
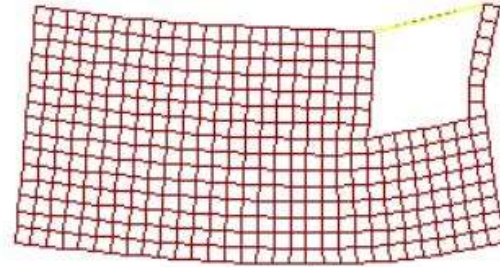
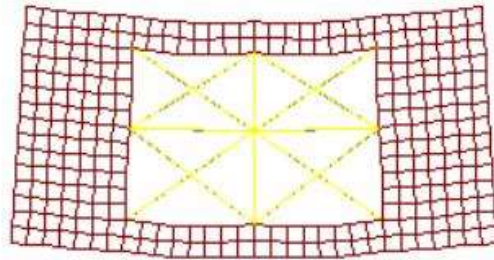



DIAFRAGMAS

Analysis Model

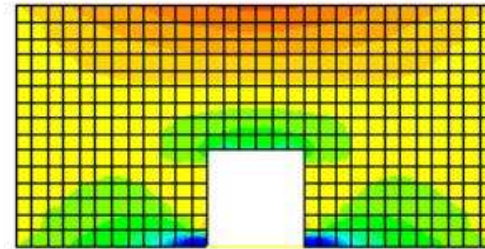
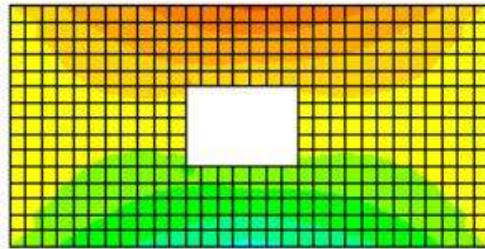
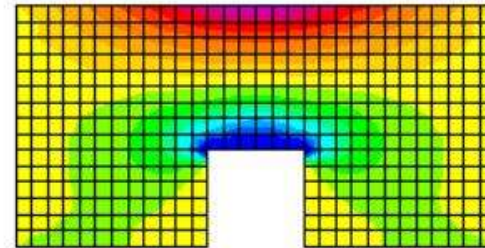
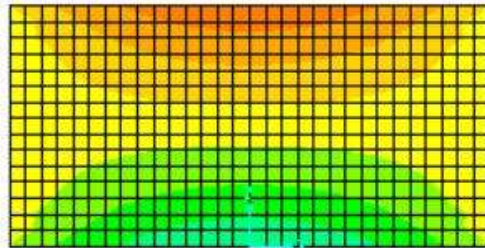
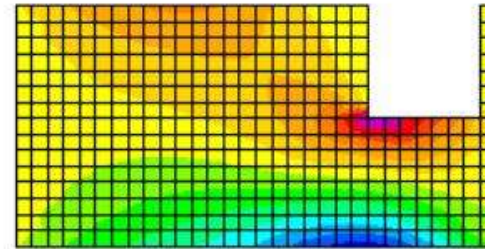
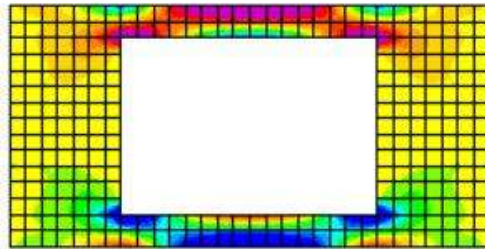
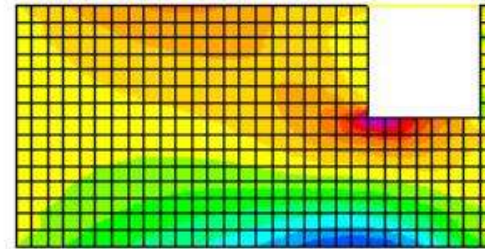
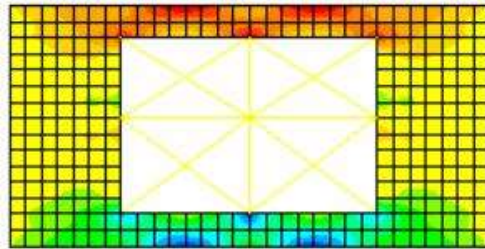



DIAFRAGMAS. CONDICIONES DEL INPRES-CIRSOC 103 / 2013

8.2. MODELACIÓN ESTRUCTURAL

8.2.1. Deformabilidad de los diafragmas

Se debe considerar la deformabilidad de los diafragmas, excepto en los casos establecidos en el Capítulo 9 para los que se admite la simplificación de considerar los diafragmas infinitamente rígidos en su plano. La condición de los diafragmas y el modo de evaluar su deformabilidad deben constar específicamente en la memoria de la estructura.

9.1.1. Condición de diafragma rígido

Se aceptará que el diafragma es rígido si cumple con las especificaciones de los artículos 9.1.1.1. ó 9.1.1.2. En cualquier caso se deben cumplir también las condiciones constructivas establecidas en las Partes II, III, IV y V de este Reglamento.

9.1.1.1. Condiciones geométricas

9.1.1.2. Condición mecánica

DIAFRAGMAS. CONDICIONES DEL INPRES-CIRSOC 103 / 2013

9.1.1.1. Condiciones geométricas

Se cumple simultáneamente:

a) Geometría general

El diafragma tiene forma de polígono convexo que puede inscribirse en un rectángulo de relación de lados máxima **1:3**.

Se admiten entrantes inferiores al **25 %** de la longitud del lado paralelo del rectángulo (formas L, T, H, E, etc.). En construcciones de hasta **3 niveles** el límite es **30%**.

b) Huecos o perforaciones (patios, escaleras, ascensores, etc.)

El área máxima de la suma de los huecos es **1/10** del área de la placa.

La dimensión sumada de todos los huecos máxima en una dirección es **1/3** de la dimensión paralela de la placa en esa dirección.

Cualquier hueco está separado de los bordes de la placa o de otros huecos como mínimo **1/4** de la dimensión de la placa en esa dirección.

Uno o más huecos separados entre si menos de **1/6** de la dimensión paralela de la planta o **1/2** de la dimensión del hueco menor serán considerados una única perforación a los fines de este artículo. Para la aplicación de esta disposición los huecos de forma irregular se podrán considerar rectángulos de dimensiones proporcionales a la relación de dimensiones paralelas del hueco equivalente.



DIAFRAGMAS. CONDICIONES DEL INPRES-CIRSOC 103 / 2013

9.1.1.2. Condición mecánica

La máxima deformación lateral del diafragma es menor o igual que dos veces la deriva de piso media en el piso considerado.

9.1.2. Solicitaciones en el diafragma debidas a la acción sísmica

El diafragma deberá ser diseñado y dimensionado para resistir solicitaciones en su plano. Las solicitaciones de origen sísmico se combinarán con las debidas a otras acciones que corresponda considerar simultáneamente.

Con las fuerzas actuantes sobre el diafragma se evaluarán las solicitaciones en su plano aplicando los métodos de análisis correspondientes al tipo estructural del diafragma.

Sólo se permitirá la disipación de energía por deformaciones plásticas en el diafragma si se aplican las exigencias del diseño por capacidad al mecanismo plástico espacial correspondiente.



FORMAS IRREGULARES DE LOS DIAFRAGMAS

DIAFRAGMAS: TRANSMISIÓN

- Analogía viga acero

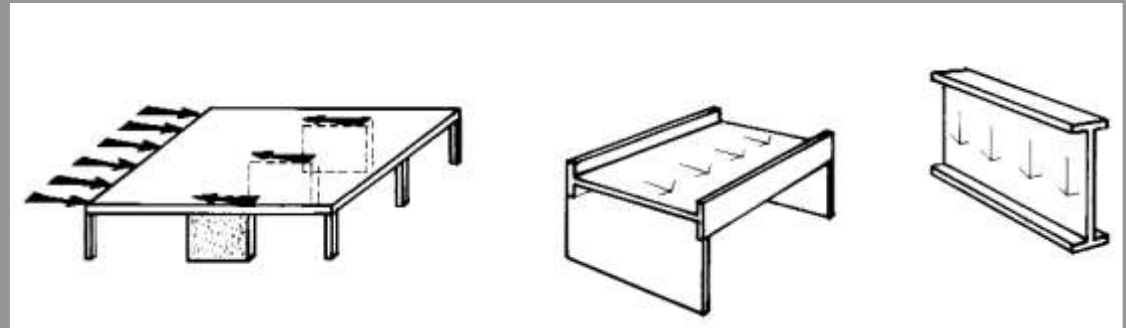

- Formas irregulares:
- Transmisión de esfuerzos

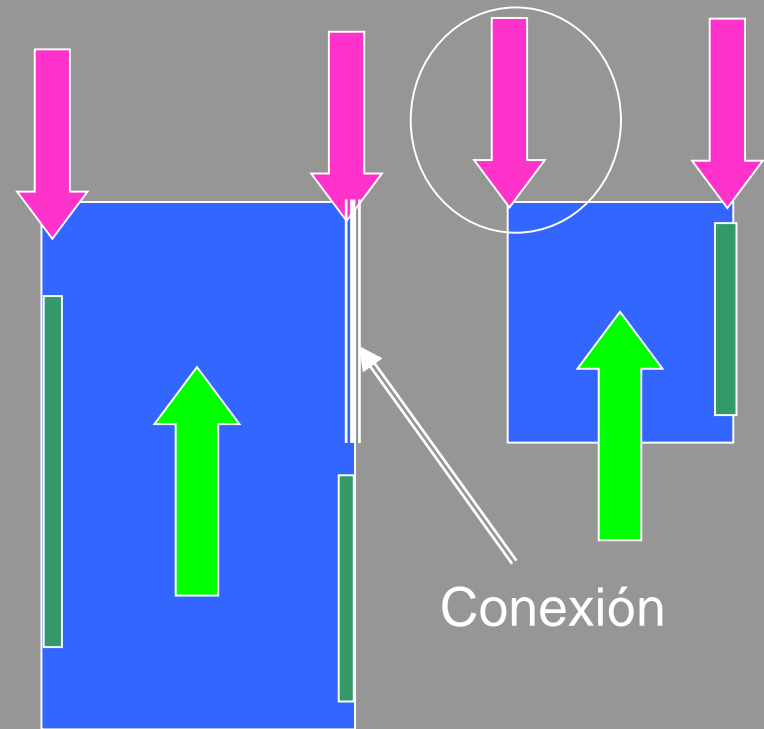
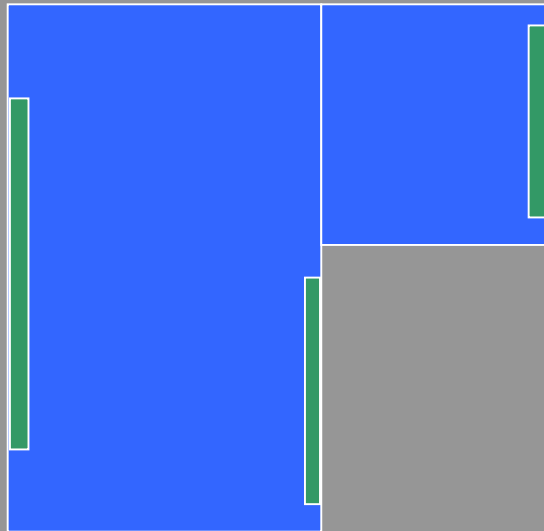

DIAFRAGMAS: TRANSMISIÓN

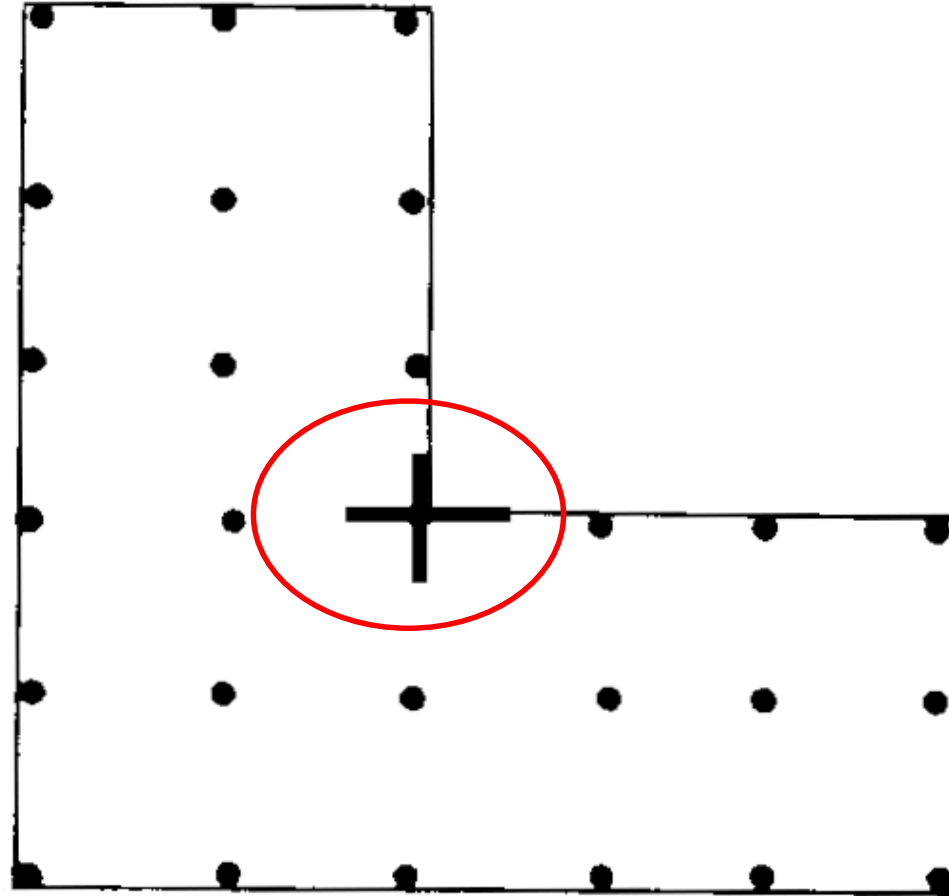

Refuerzo de ángulos entrantes



DIAFRAGMAS: TRANSMISIÓN

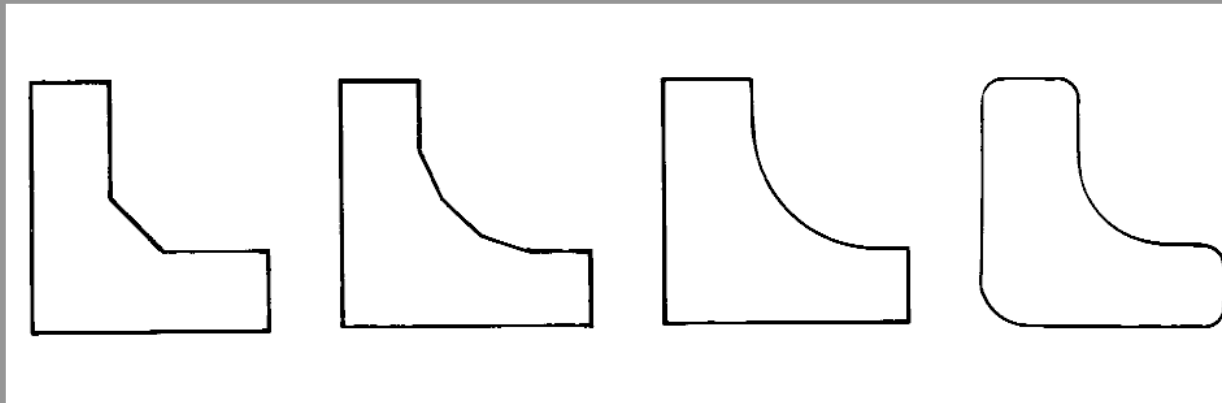

Variación progresiva de la rigidez





REGULARIDAD EN PLANTA

Plantas

Sencillas			Complejas		

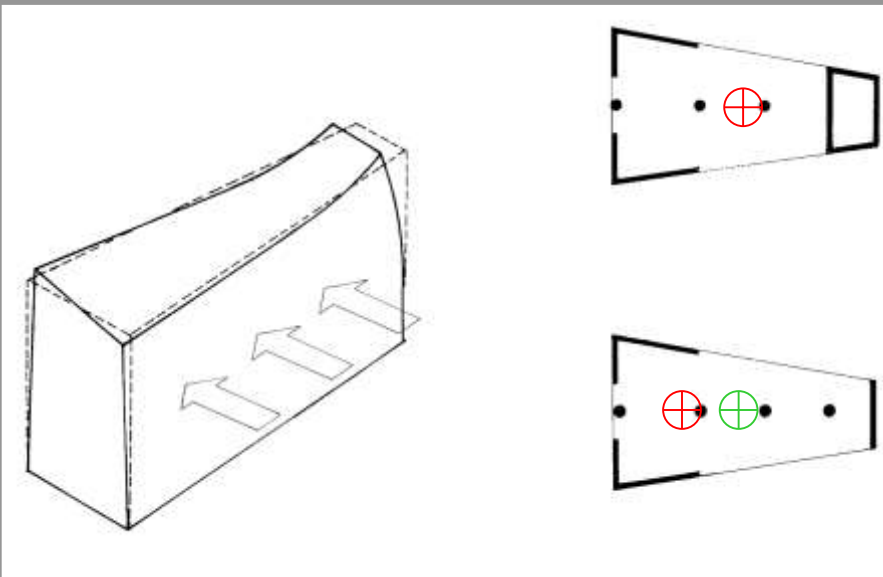
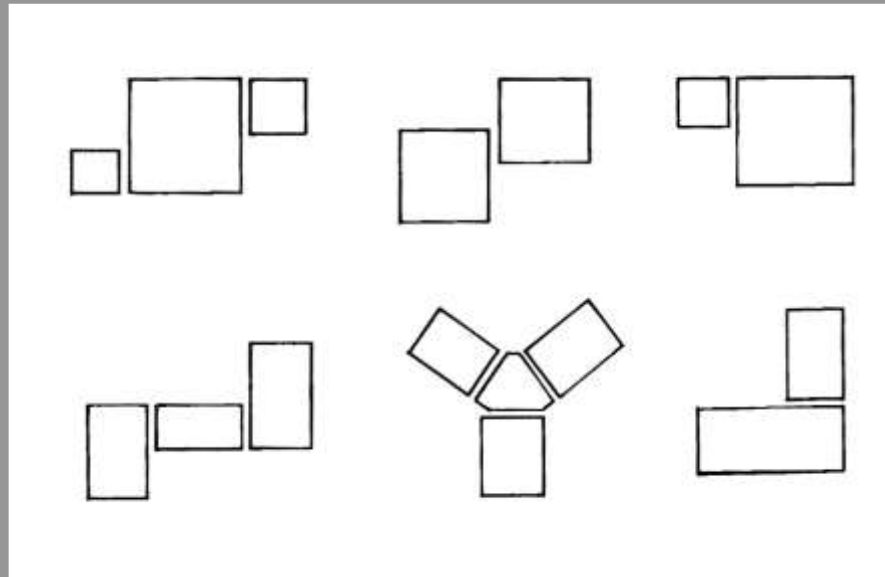

Rigidez compensada

Rigidez descompensada



IRREGULARIDADES EN PLANTA

Figura 2.
Formas de la planta

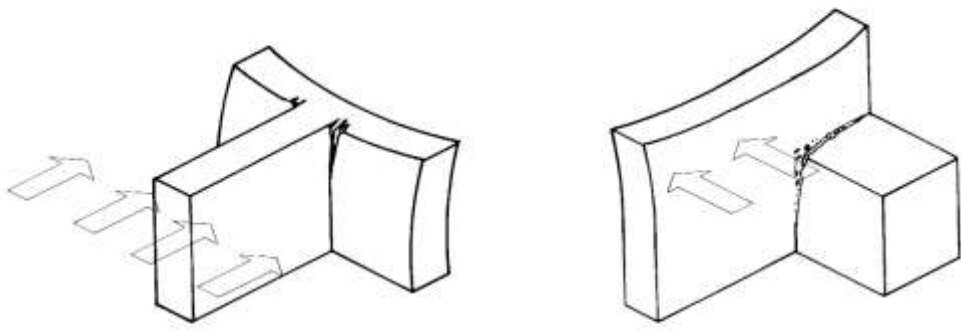
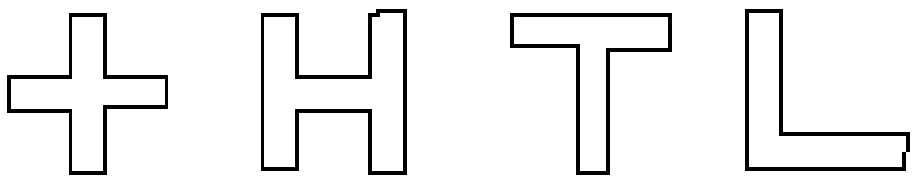
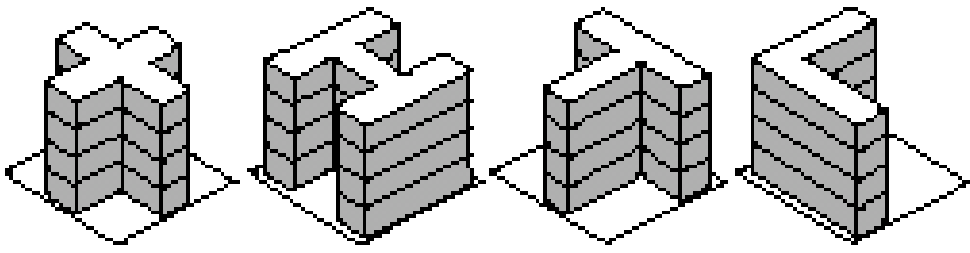

IRREGULARIDADES EN ALTURA

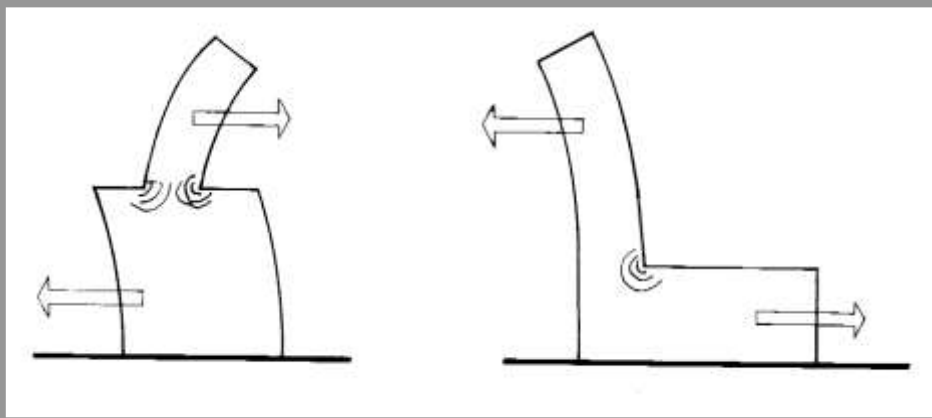
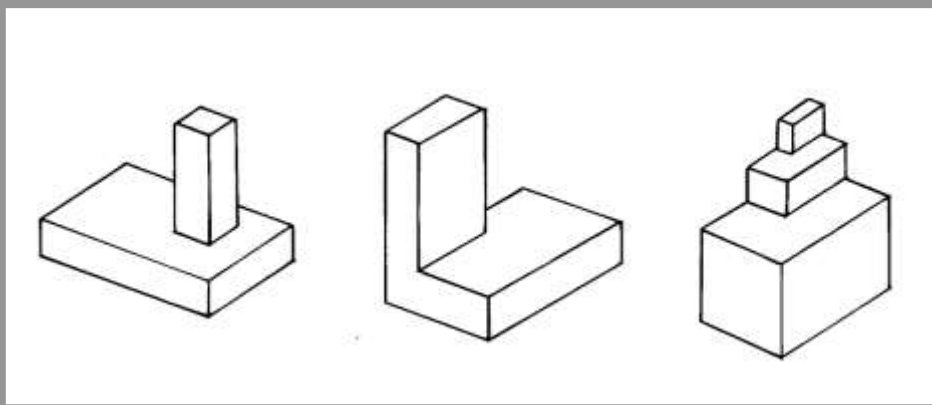
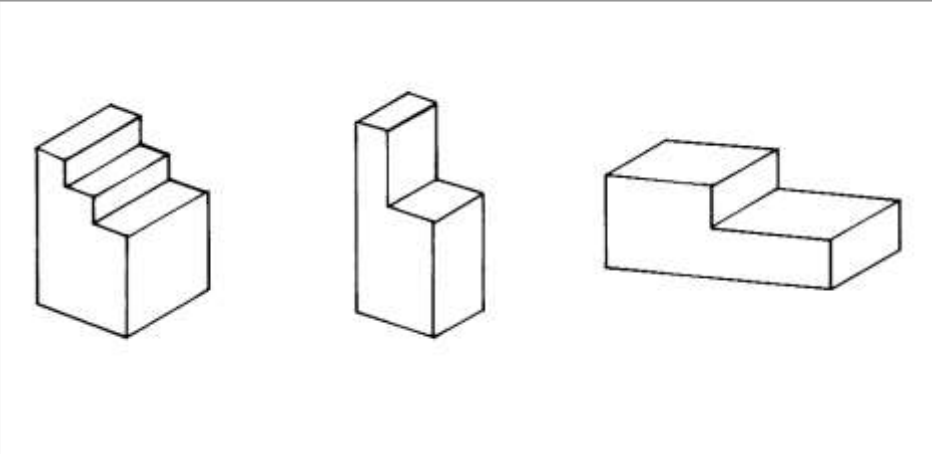

IRREGULARIDADES EN ALTURA

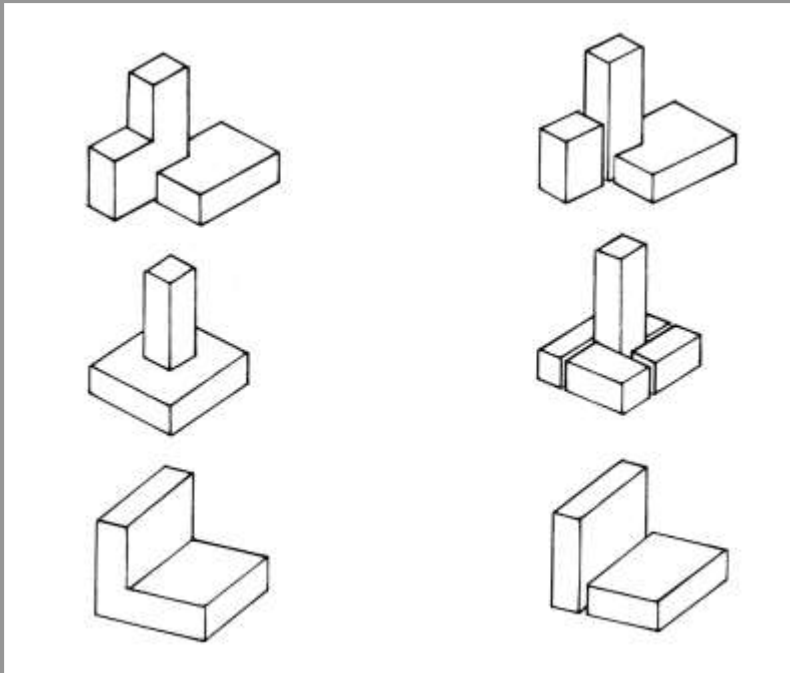

Fraccionamiento del edificio

Cambios progresivos

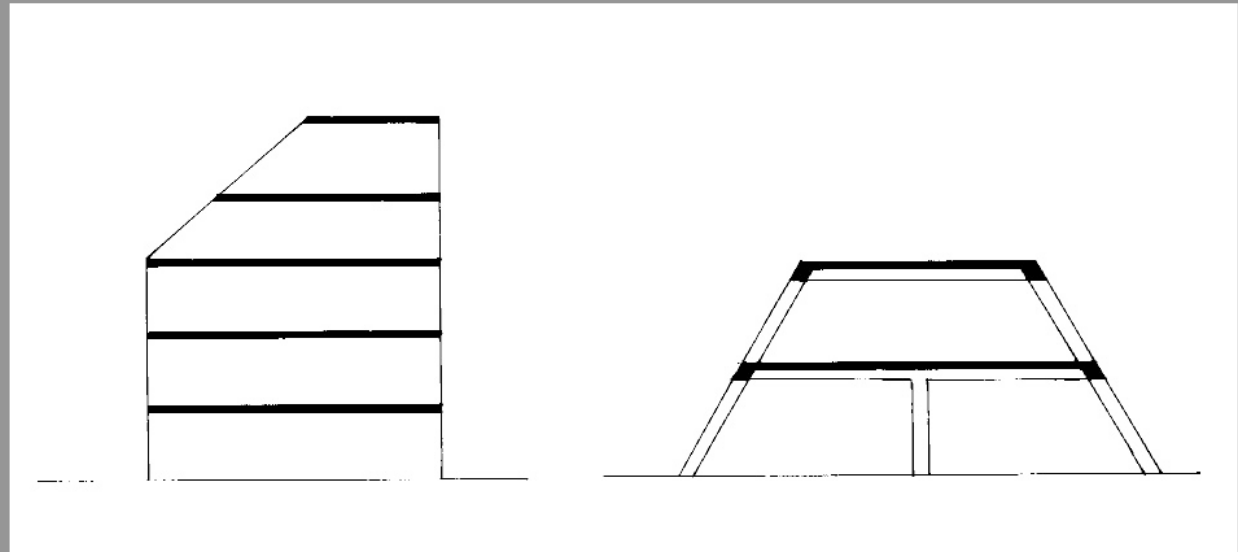



JUNTAS Y COLINDANCIA



COLINDANCIA

- Definición
- Problema
- Solución

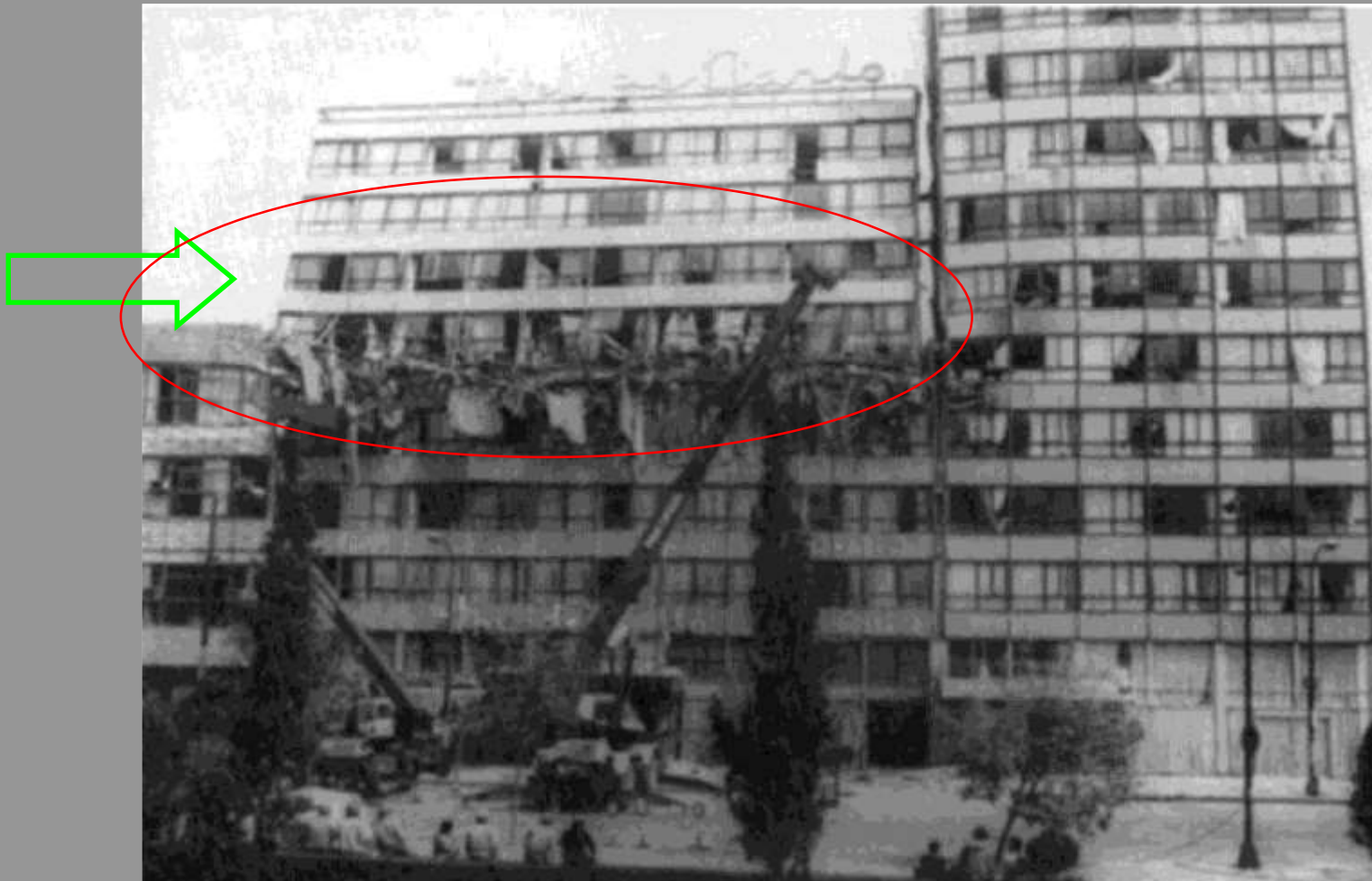

COLINDANCIA

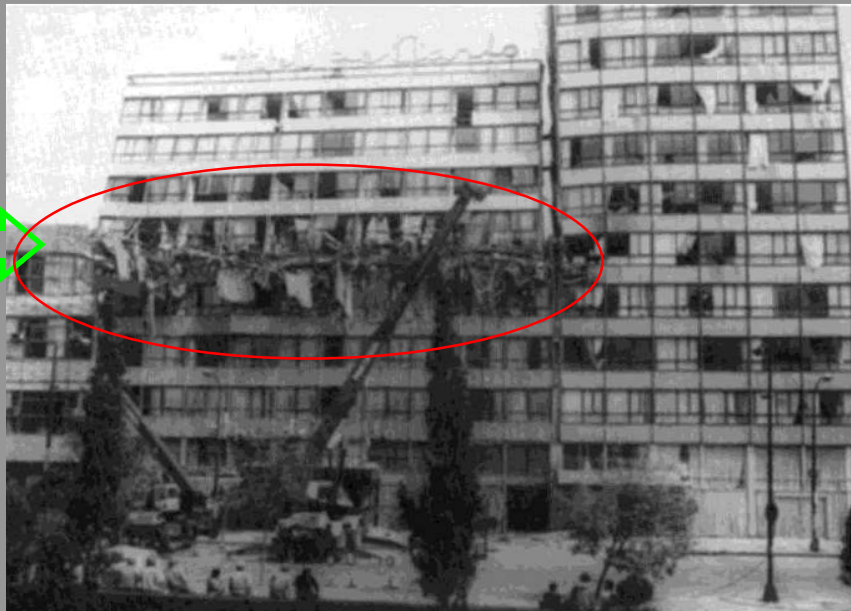

COLINDANCIA

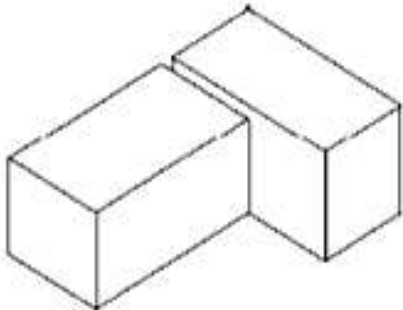
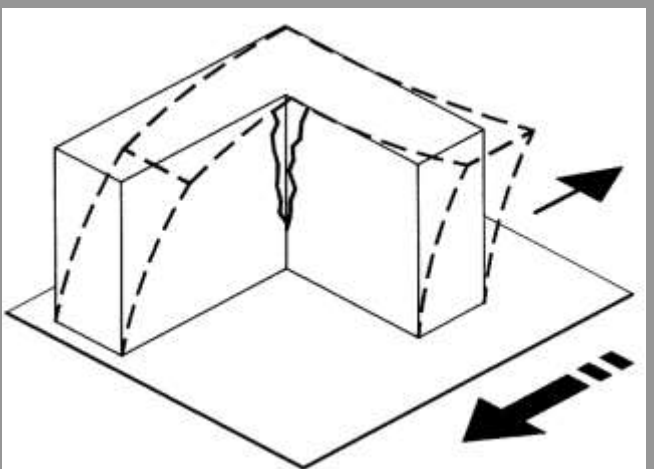
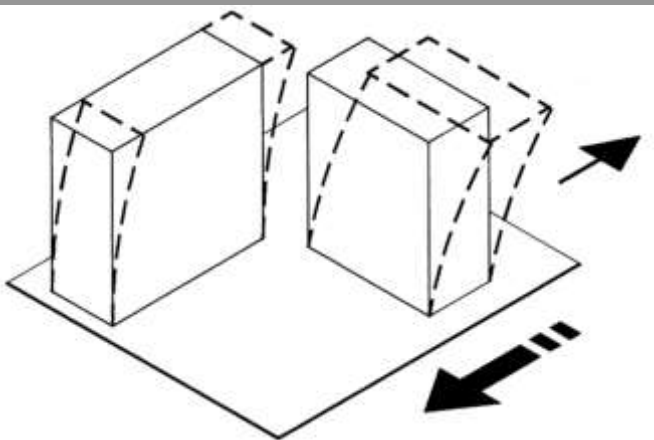
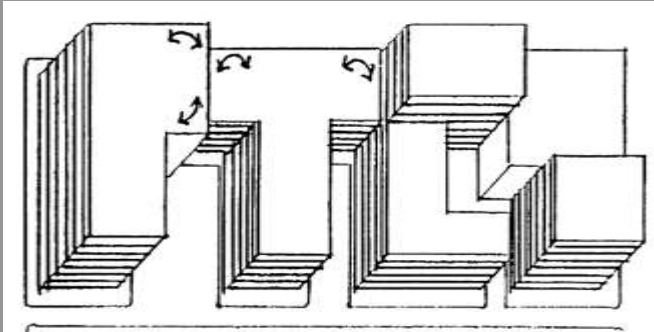

SEPARAR LOS CUERPOS

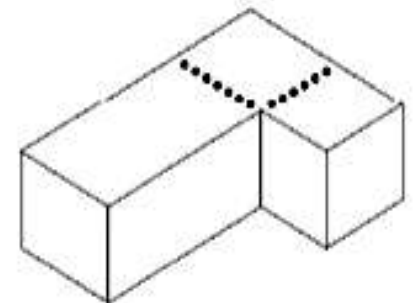

AGREGAR COLECTORES

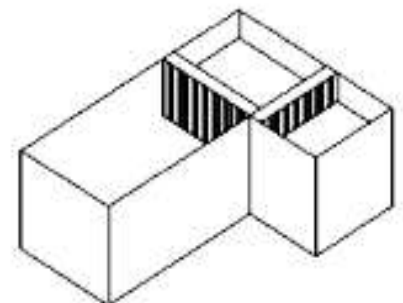

AGREGAR MUROS COLECTORES

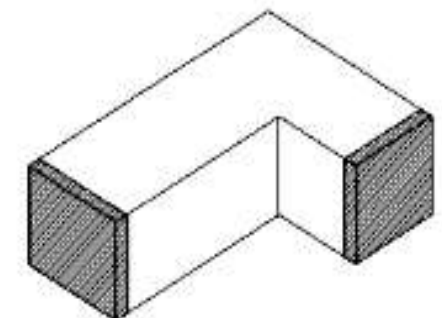

RIGIDIZAR LOS EXTREMOS

COLINDANCIA

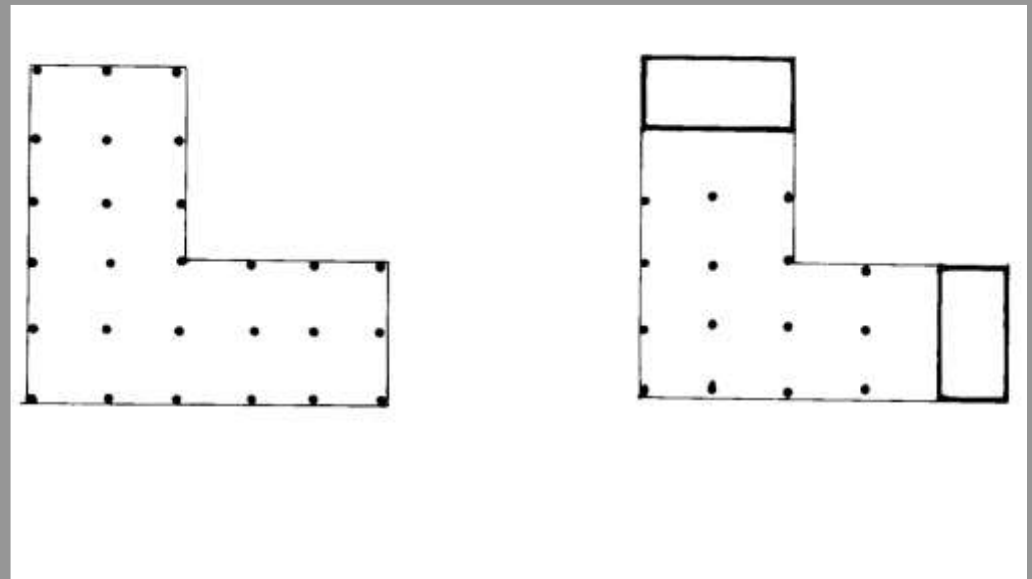
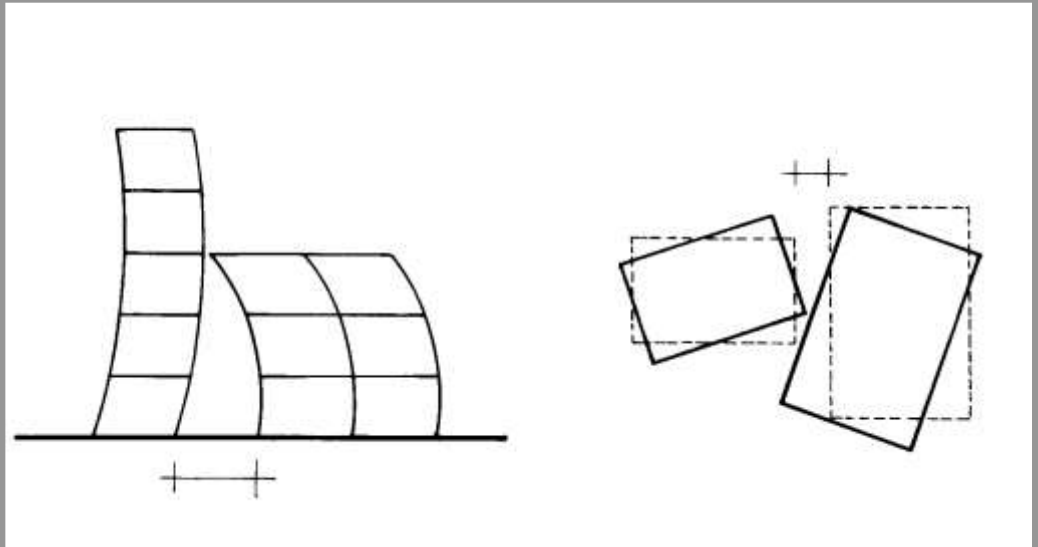

DIAFRAGMAS Y JUNTAS

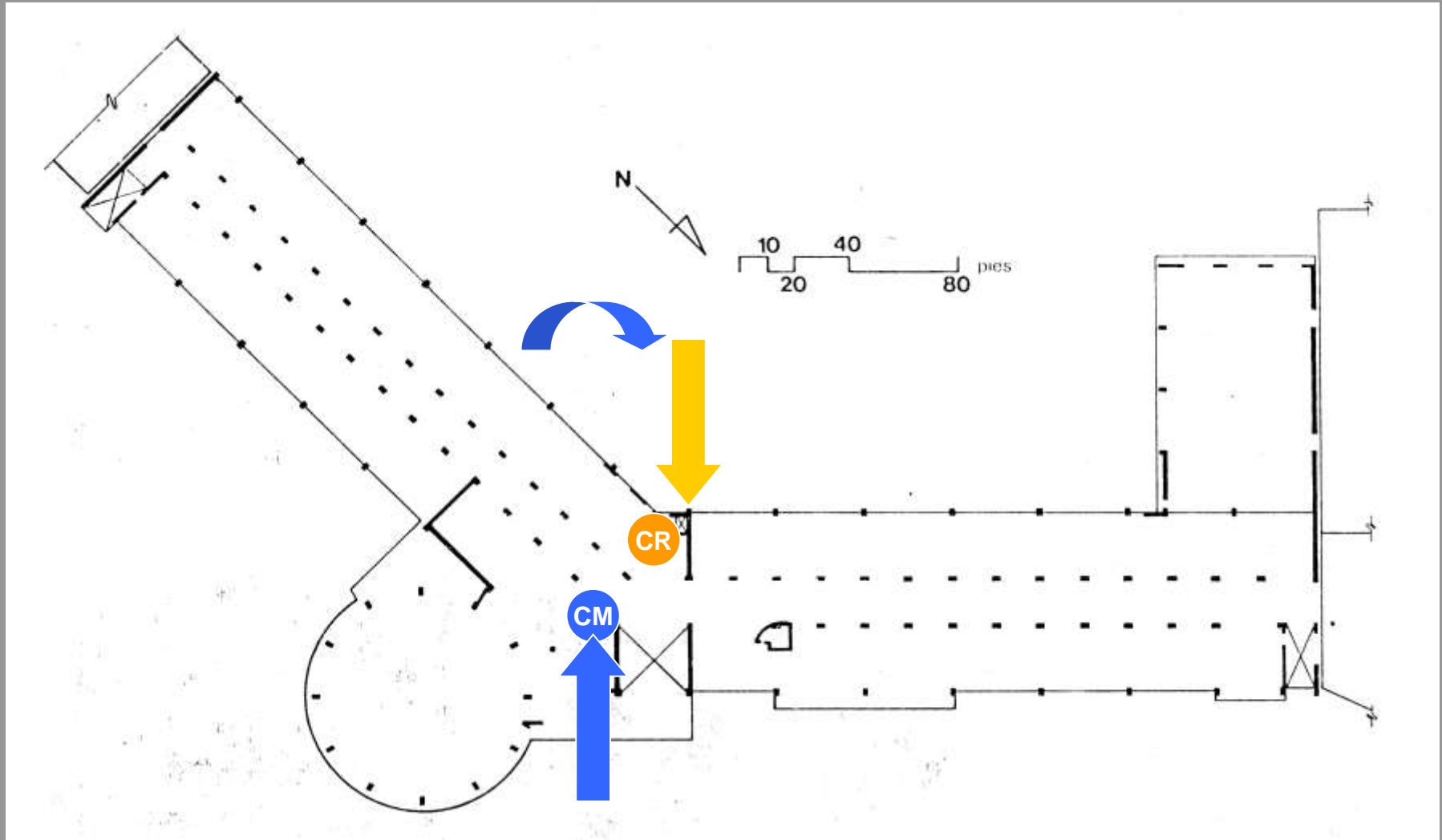



DIAFRAGMAS Y JUNTAS

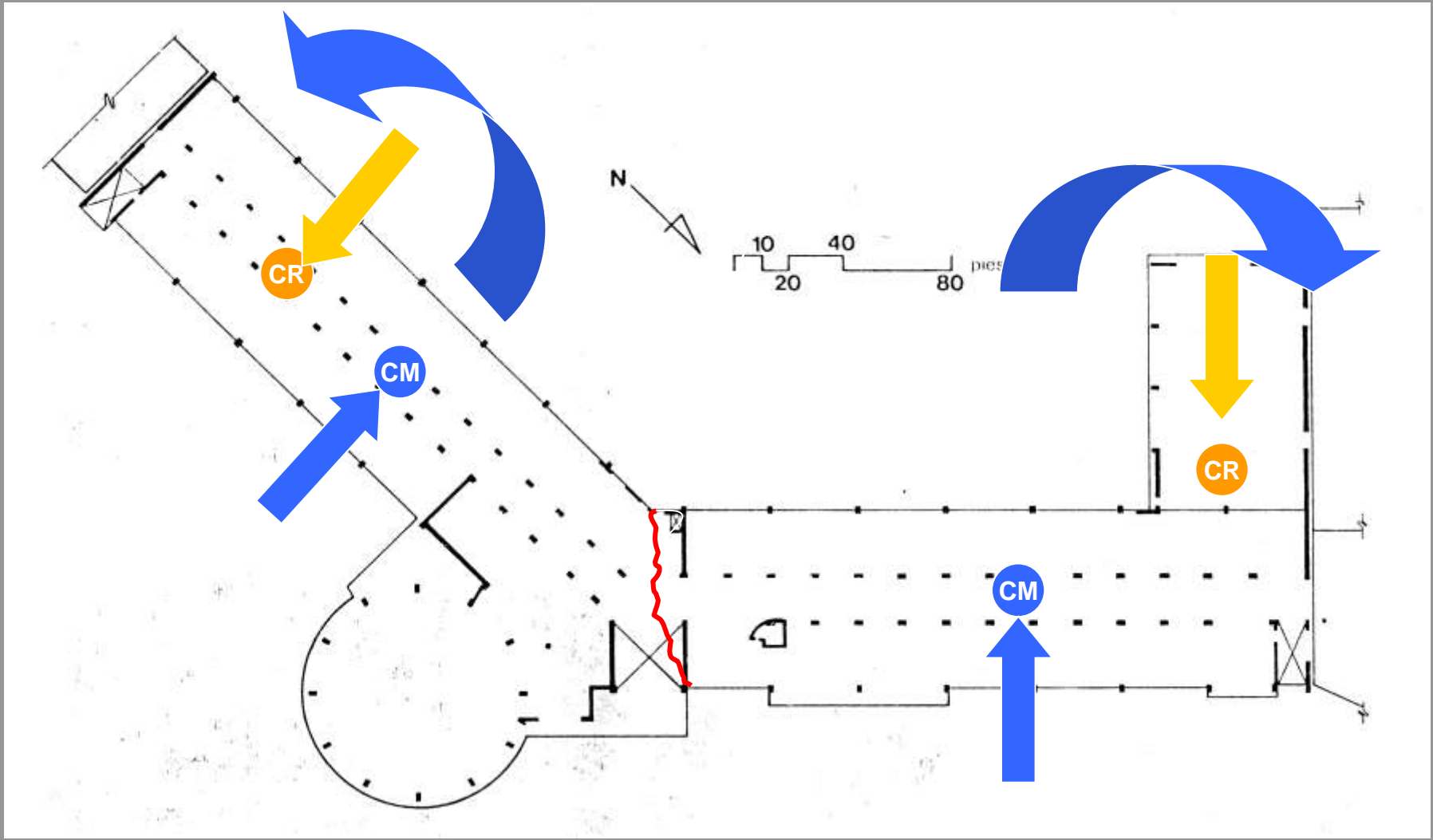



DIAFRAGMAS Y JUNTAS



Sin junta



Sin junta, c/refuerzo

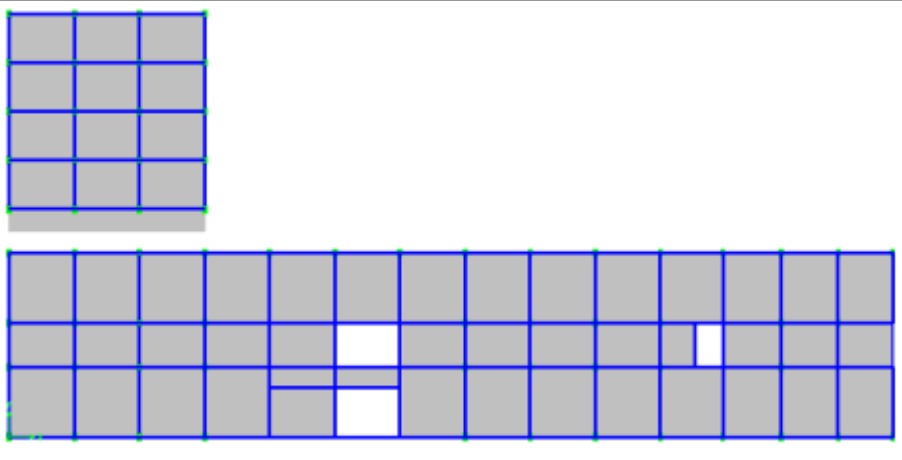

Con junta



DIAFRAGMAS Y JUNTAS

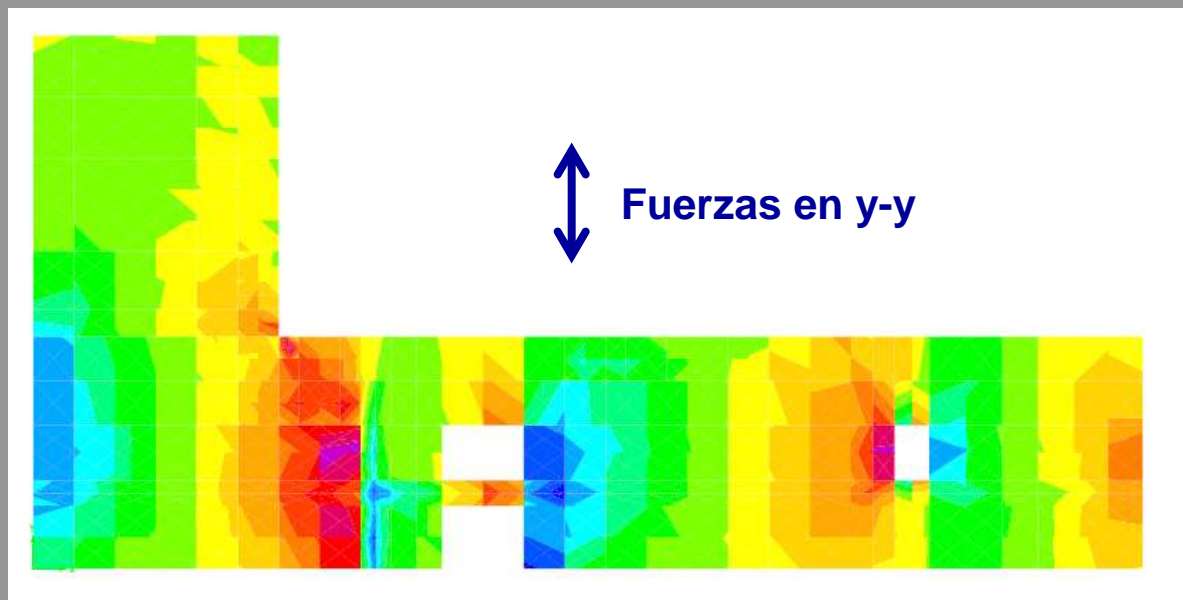
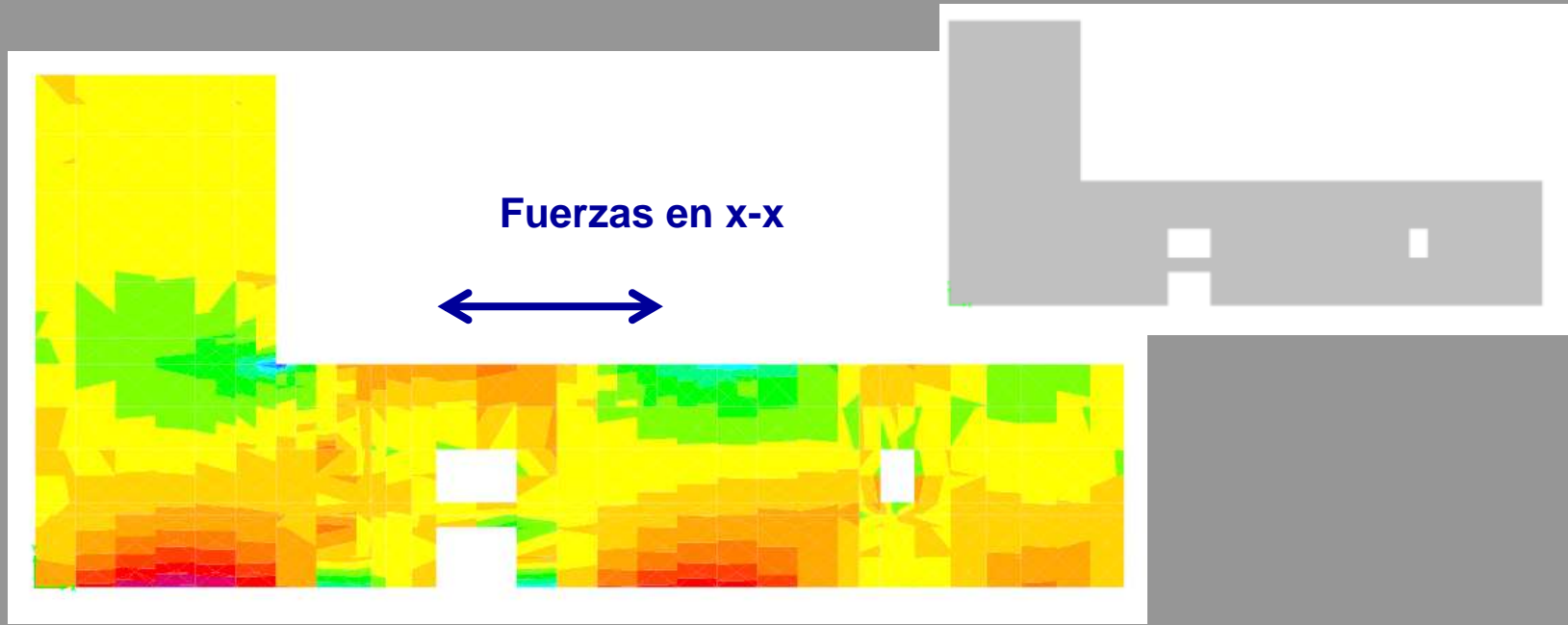

DIAFRAGMAS Y JUNTAS

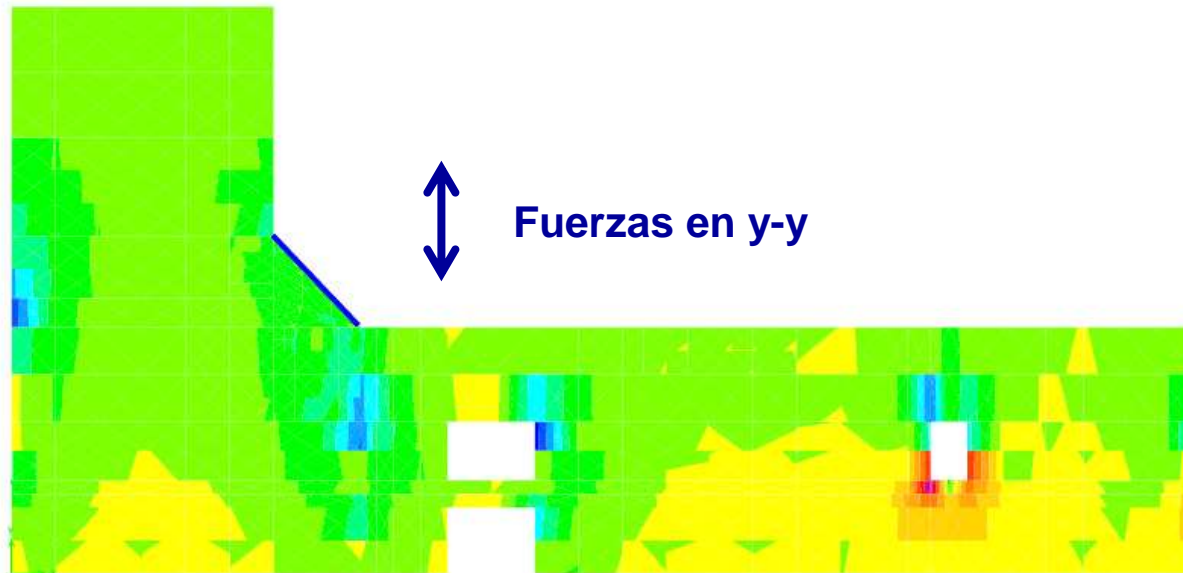
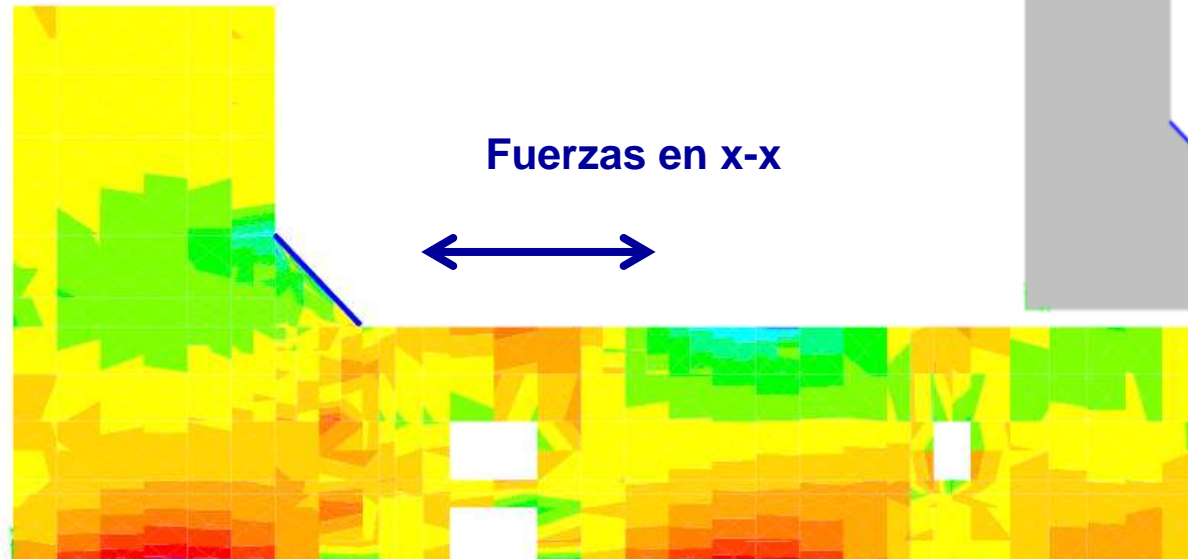



DIAFRAGMAS Y JUNTAS

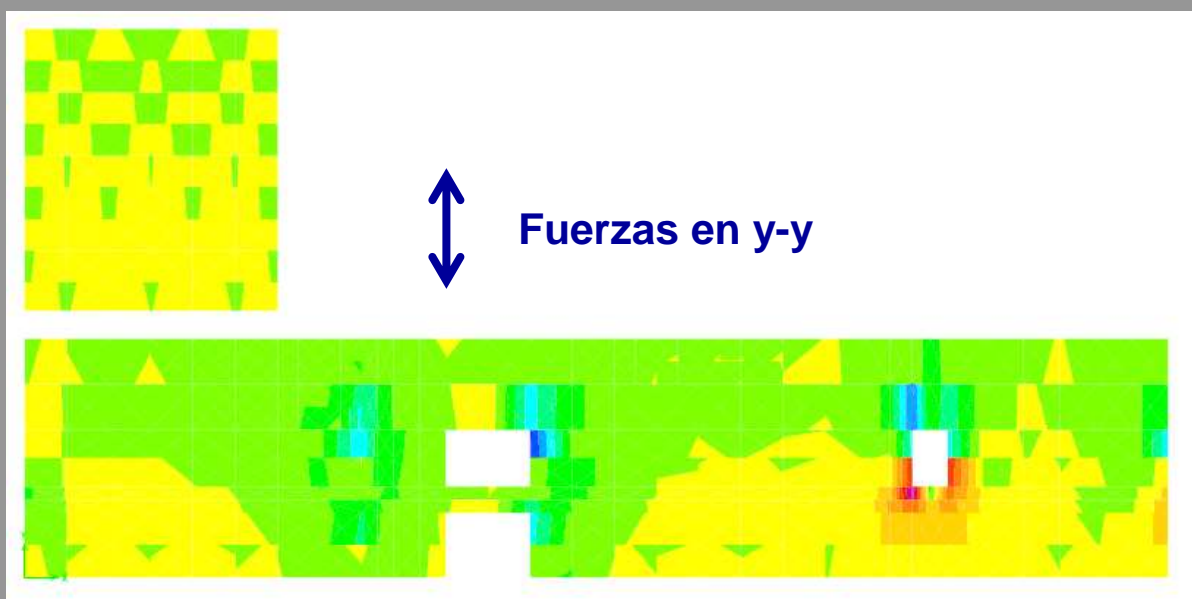
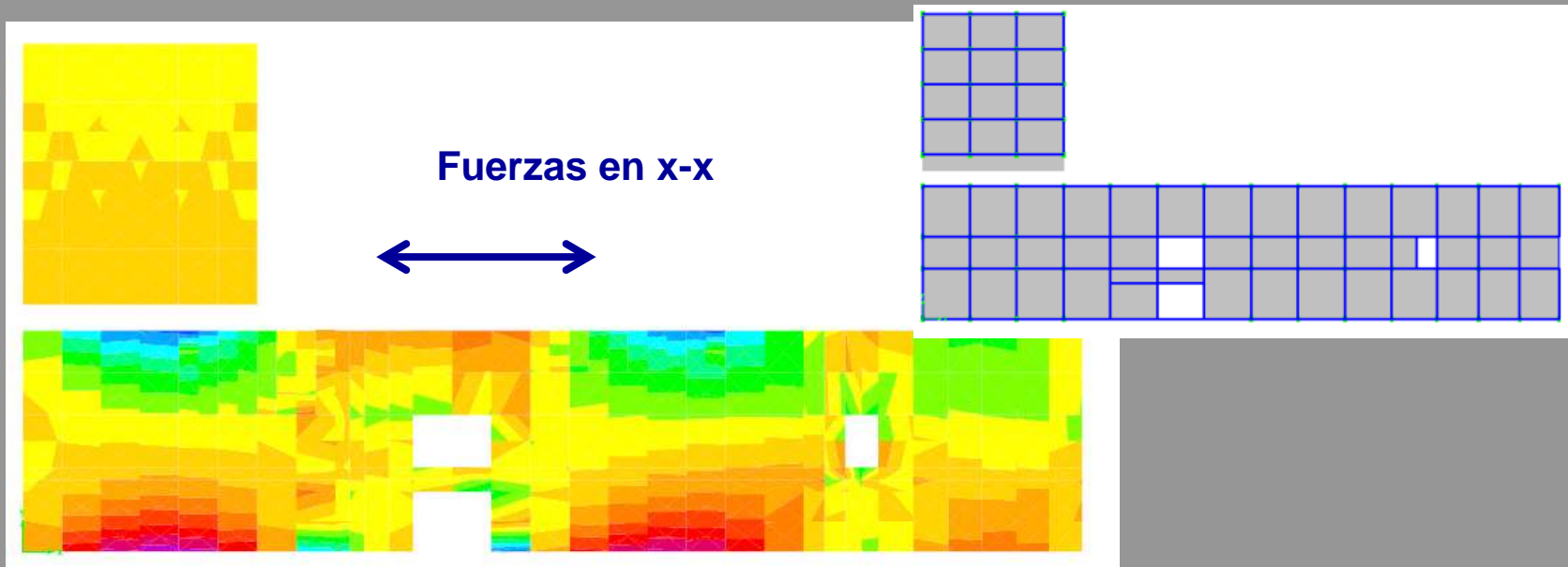



DIAFRAGMAS Y JUNTAS

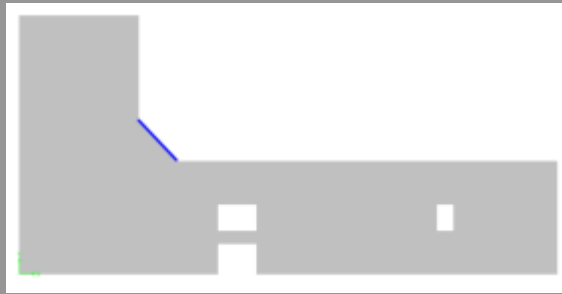

Sin junta, c/refuerzo



Sin junta

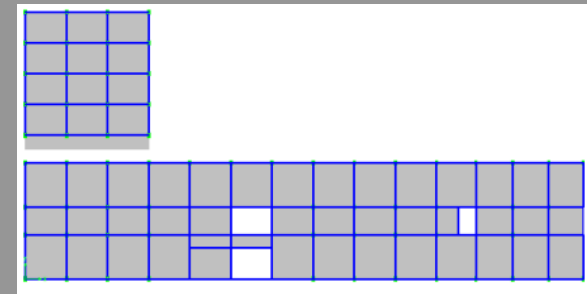

Con junta

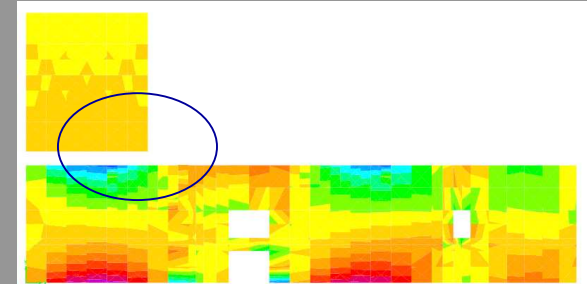
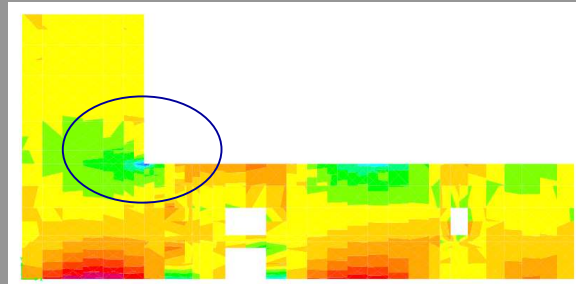
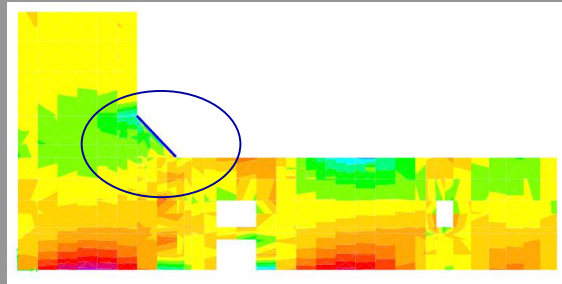

Fuerzas en x-x

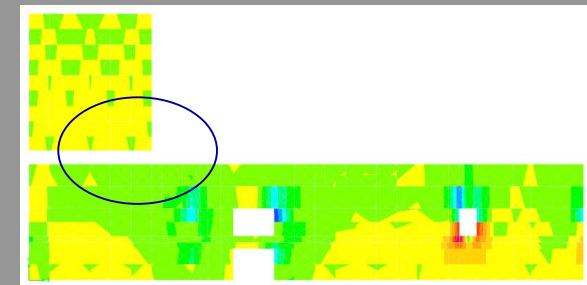
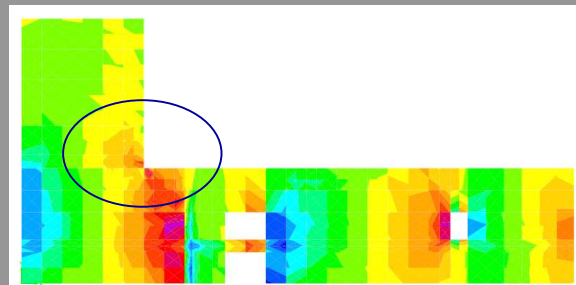
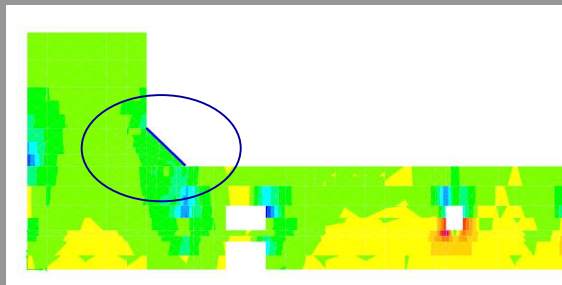

Fuerzas en y-y

DISEÑO ESTRUCTURAL III

DISEÑO SISMORRESISTENTE

DIAFRAGMAS

JUNTAS Y COLINDANCIA

FIN