



UNCUYO
UNIVERSIDAD
NACIONAL DE CUYO

ESTÁTICA Y RESISTENCIA DE MATERIALES

RETICULADOS

RETICULADOS

- *“Una estructura constituida por varias barras (de hierro, madera u hormigón) unidas por sus extremos en puntos llamados nudos, de manera tal que el conjunto así formado sea indeformable, se denomina **armadura o reticulado rígido**”.-*
- Si a esta estructura le agregamos los vínculos que la fijan a tierra, hablamos de ***sistema reticulado***.-

ESFUERZOS EN RETICULADOS

TRACCIÓN – COMPRESIÓN

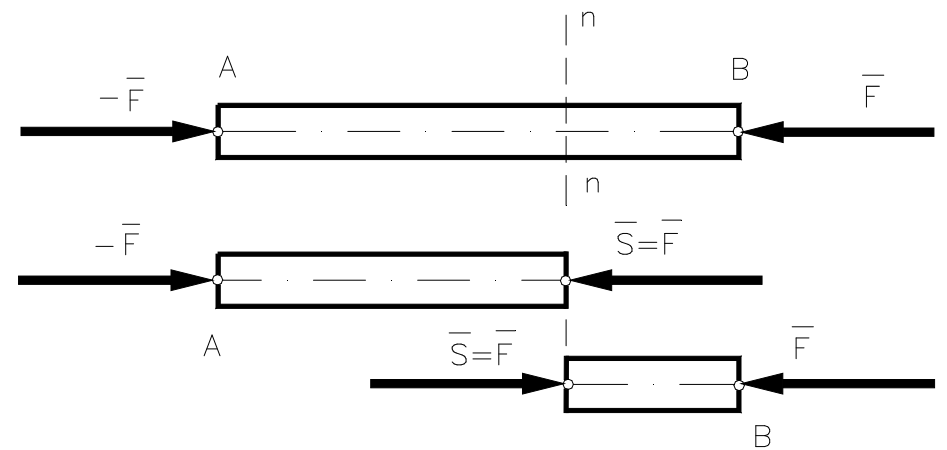
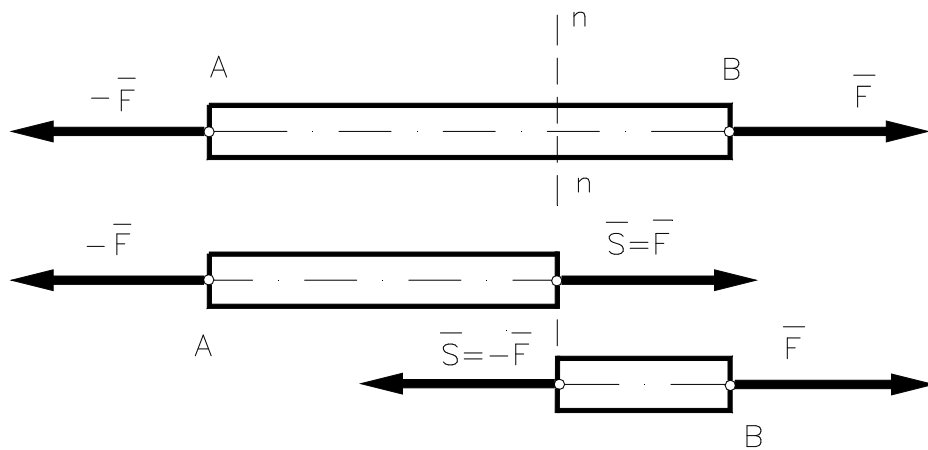

RETICULADOS PLANOS

RETICULADOS PLANOS



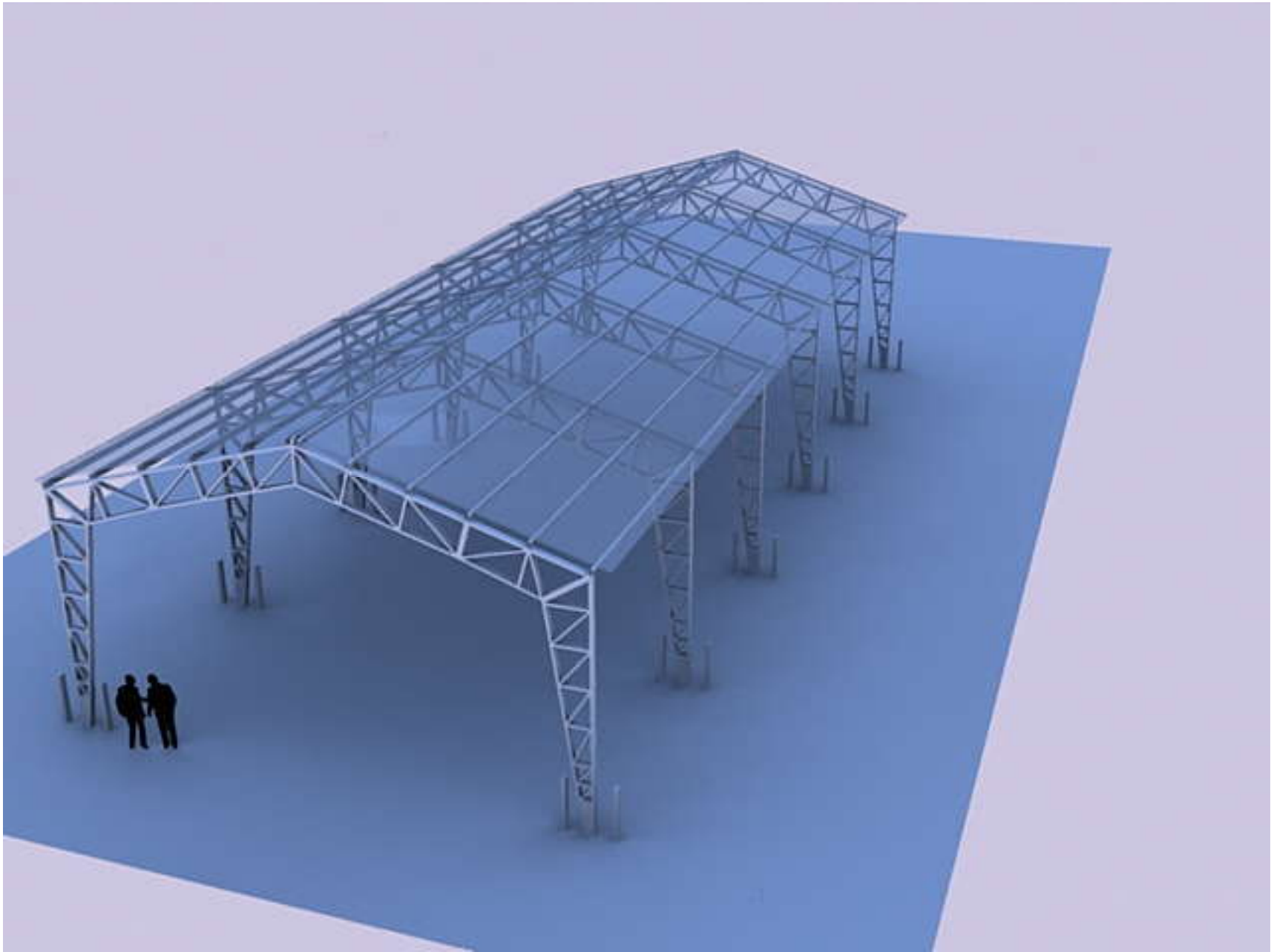

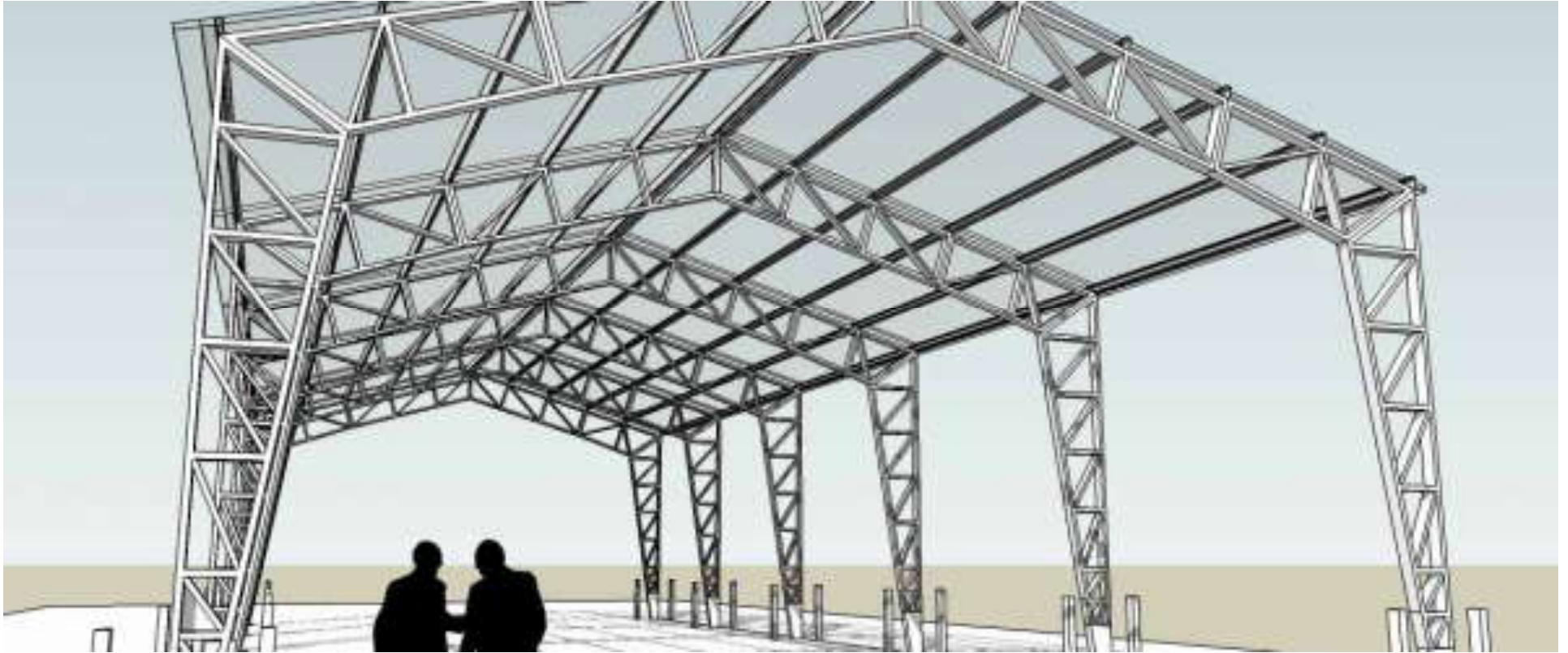

Reticulados para galpones





MENDOZA



Astoria-Megler Bridge (Astoria, EEUU)



DETERMINACION DE ESFUERZOS EN BARRAS

HIPÓTESIS

RETICULADOS

- Para determinar los esfuerzos que se originan en las barras se formulan dos hipótesis que, con la suficiente aproximación, permiten abordar el cálculo con sencillez.-
- Se supone primero *que las barras se encuentran articuladas en los nudos* y,
- en segundo término, *que las fuerzas exteriores actúan solamente en ellos*.-

RETICULADOS

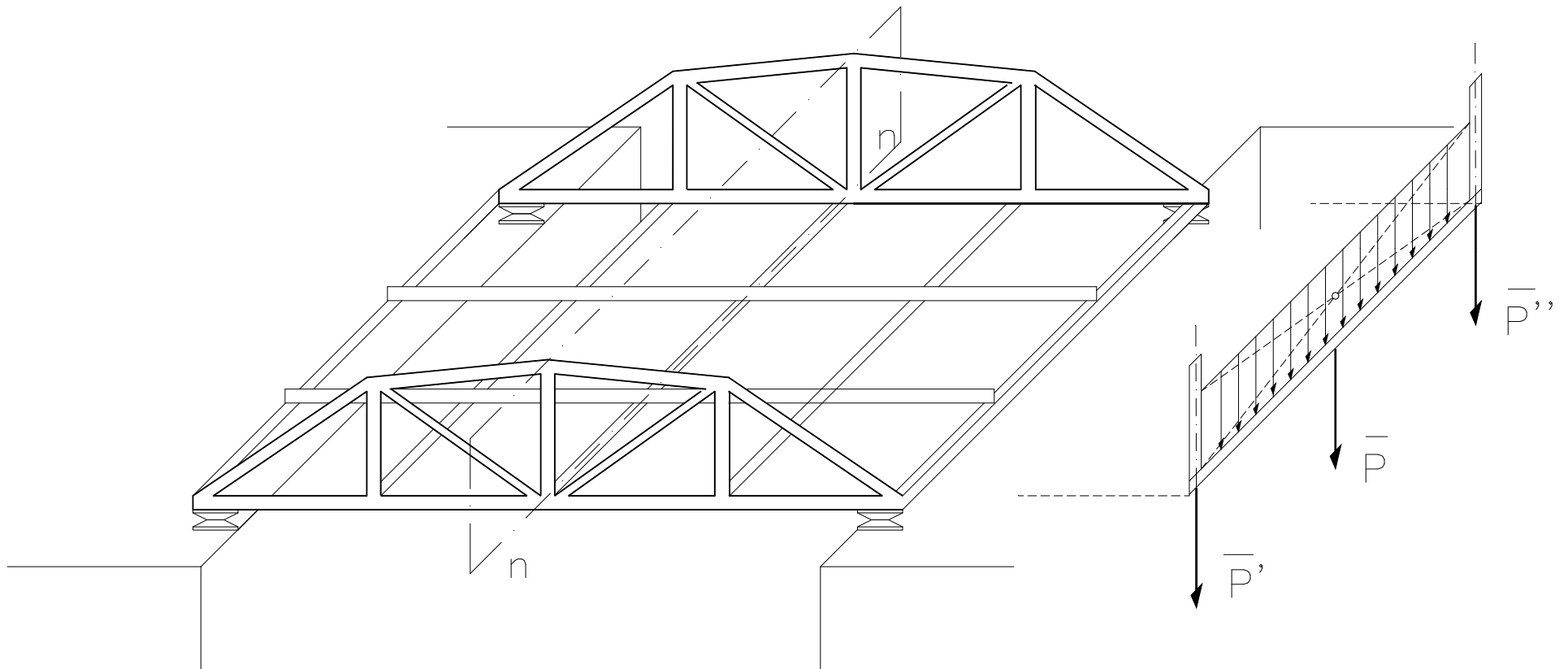

RETICULADOS

NUDOS

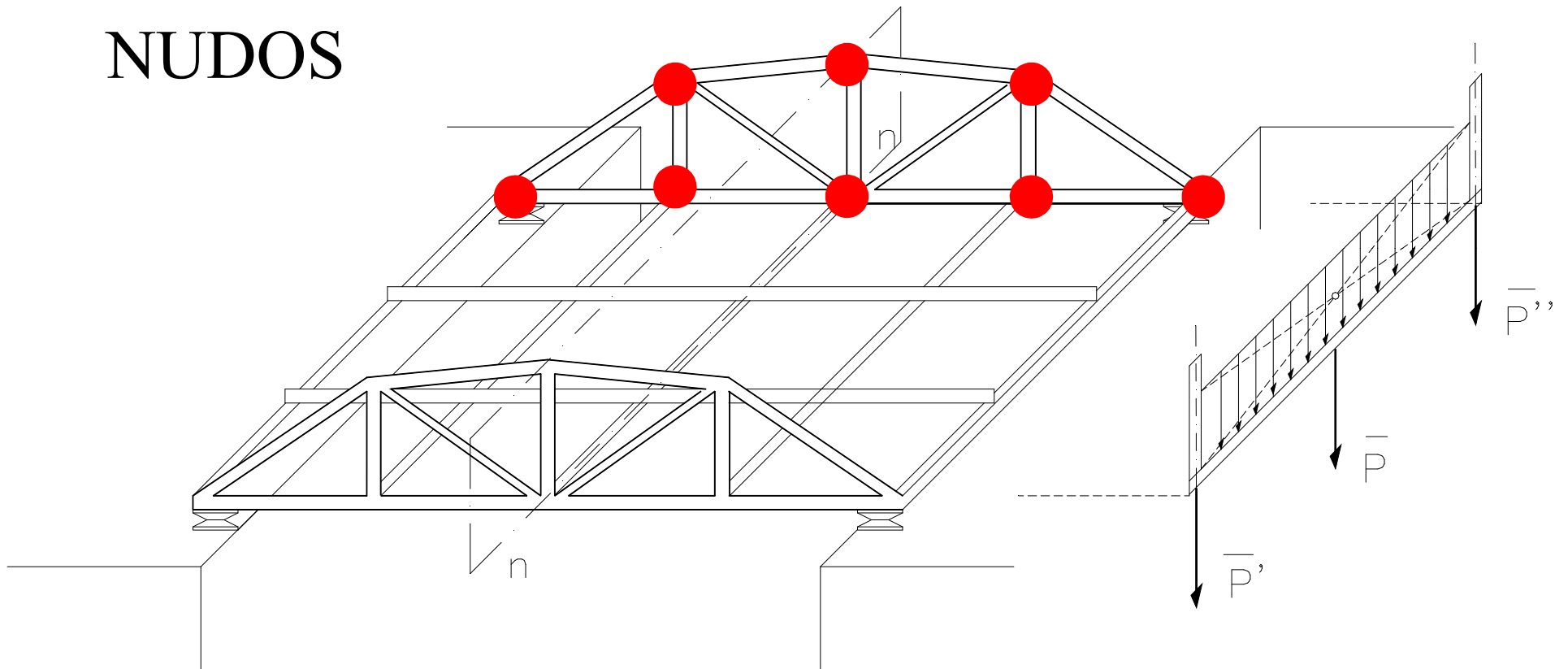

RETICULADOS

NUDOS

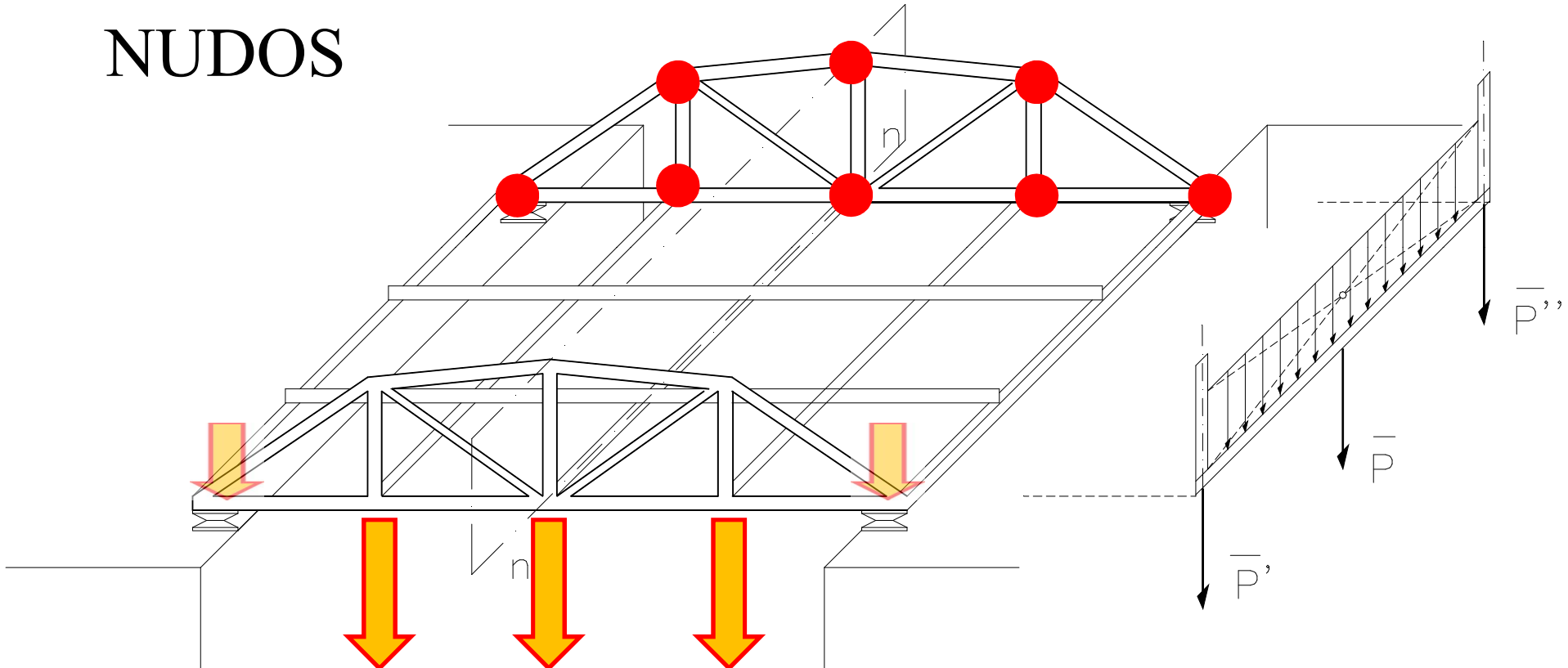

CARGAS

DETERMINACION DE ESFUERZOS EN BARRAS

MÉTODO DE LOS NUDOS

MÉTODO DE LAS SECCIONES

MÉTODO DE LOS NUDOS

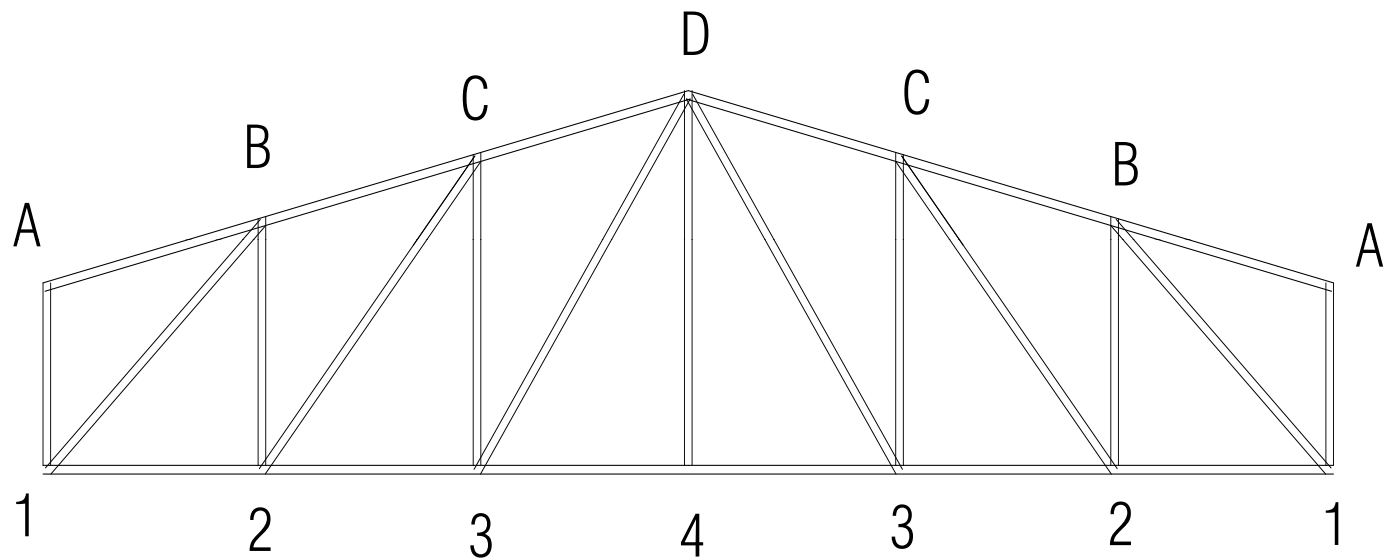

MÉTODO DE LOS NUDOS

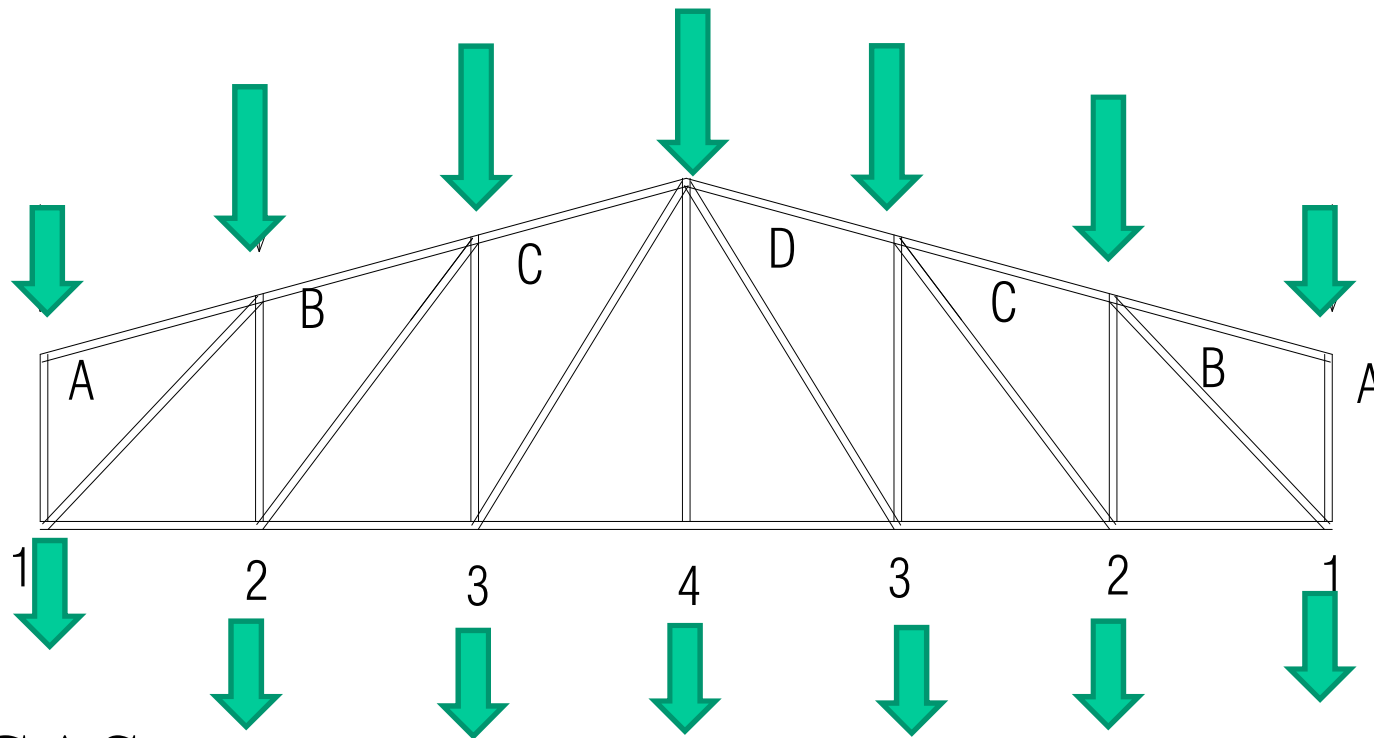

CARGAS

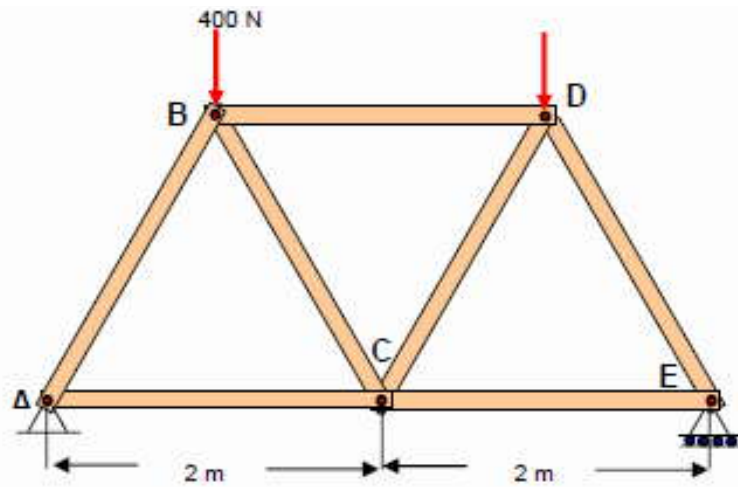

Armadura **WARREN** soportando dos cargas

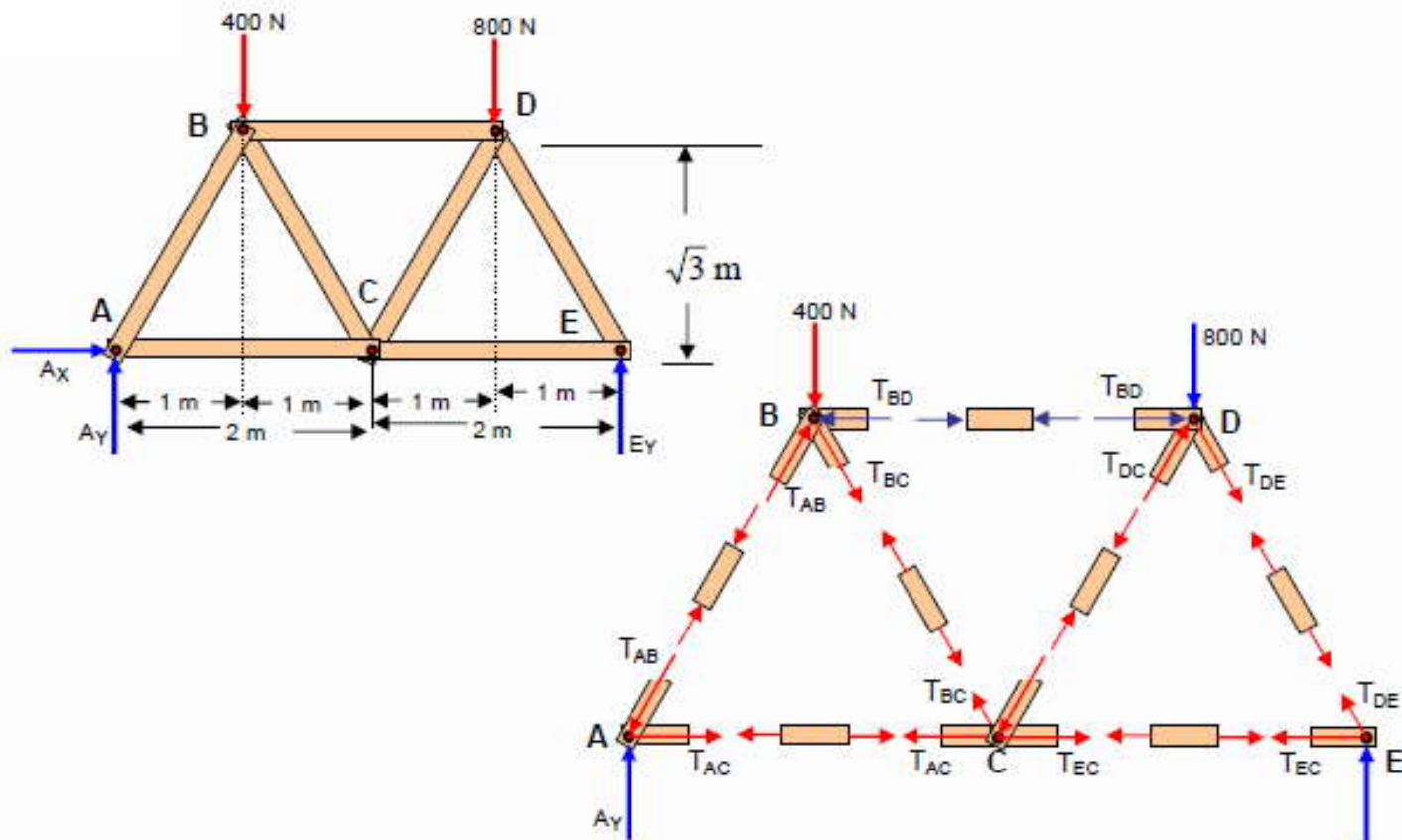

EJERCICIO MODELO

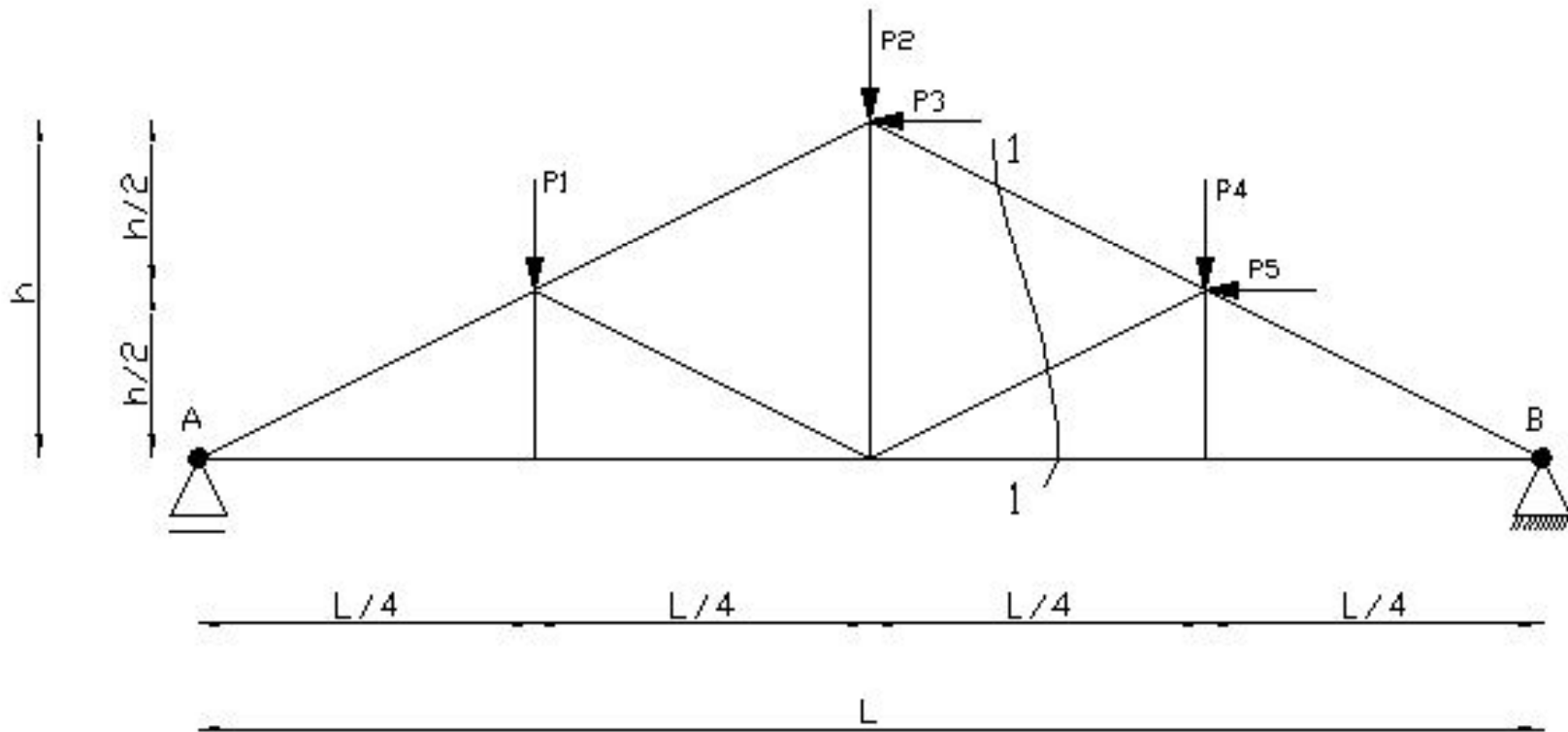

P_1 a $P_5=30\text{KN}$

$L=16\text{m}$; $h=4\text{m}$



Diagrama de cuerpo libre



$$b = 2v - 3$$

- L = 16 m
- h = 4 m
- P1 = 30 KN
- P2 = 30 KN
- P3 = 30 KN
- P4 = 30 KN
- P5 = 30 KN
- $\alpha = 26.6^\circ$

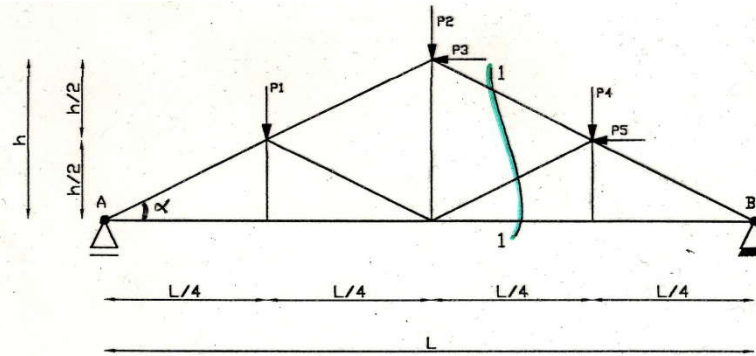
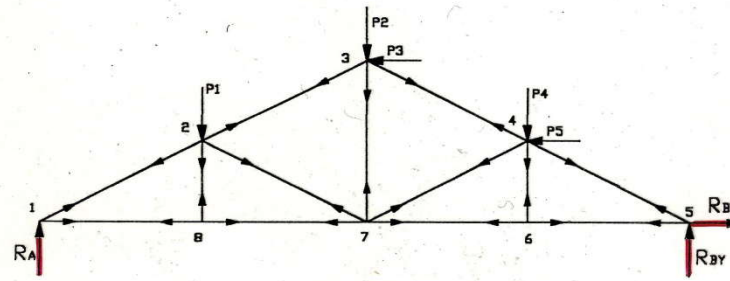
Resolución Ejercicio Modelo:

$$\sum F_x = 0 = -P_3 - P_5 + R_{BX} = 0$$

$$R_{BX} = P_3 + P_5 =$$

60.0 KN

$$\sum M_B = 0 = R_A \cdot L - P_1 \cdot 3/4 \cdot L - P_2 \cdot L/2 - P_3 \cdot h - P_5 \cdot h/2 - P_4 \cdot L/4 = 0$$

$$R_A = (P_1 \cdot 3/4 \cdot L + P_2 \cdot L/2 + P_3 \cdot h + P_5 \cdot h/2 + P_4 \cdot L/4) / L =$$

56.3 KN

$$\sum M_A = 0 = P_1 \cdot L/4 + P_2 \cdot L/2 - P_3 \cdot h - P_5 \cdot h/2 + P_4 \cdot 3/4 \cdot L - R_{BY} \cdot L = 0$$

$$R_{BY} = (P_1 \cdot L/4 + P_2 \cdot L/2 - P_3 \cdot h - P_5 \cdot h/2 + P_4 \cdot 3/4 \cdot L) / L =$$

33.75 KN

Verificación de reacciones:

$$\sum F_y = R_A + R_{BY} - P_1 - P_2 - P_4 = 0.0 \text{ KN}$$

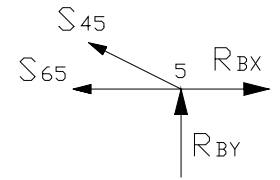
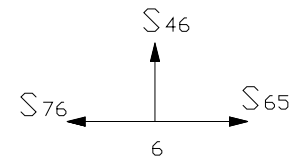
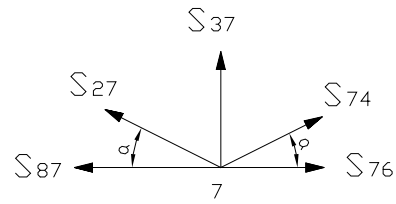
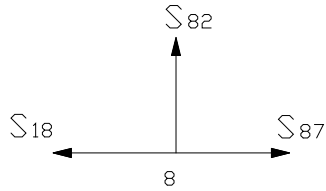
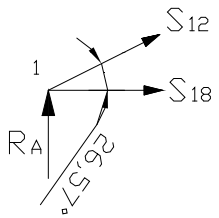
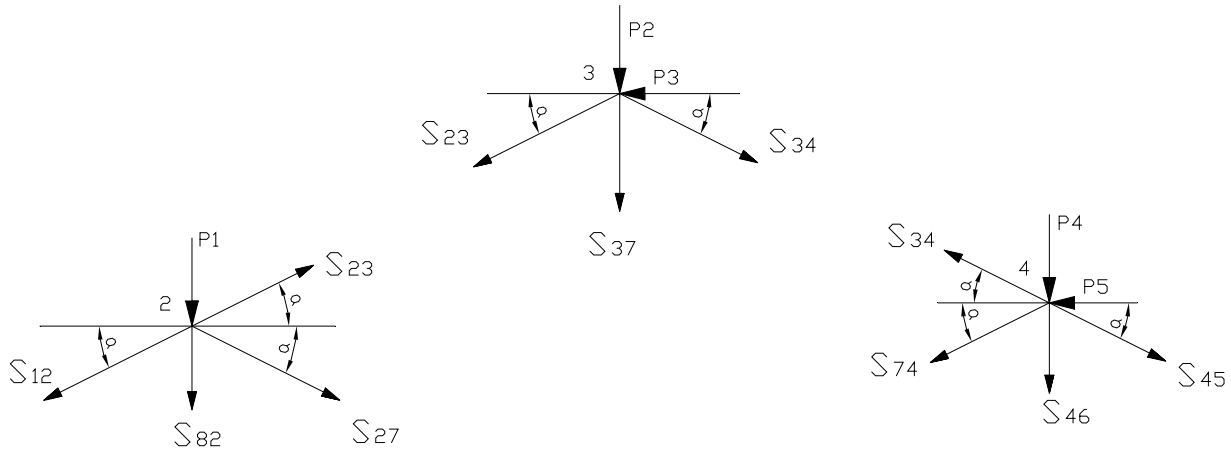

$$\Sigma X = 0$$

$$\Sigma Y = 0$$

EJERCICIO MODELO

NUDO 1

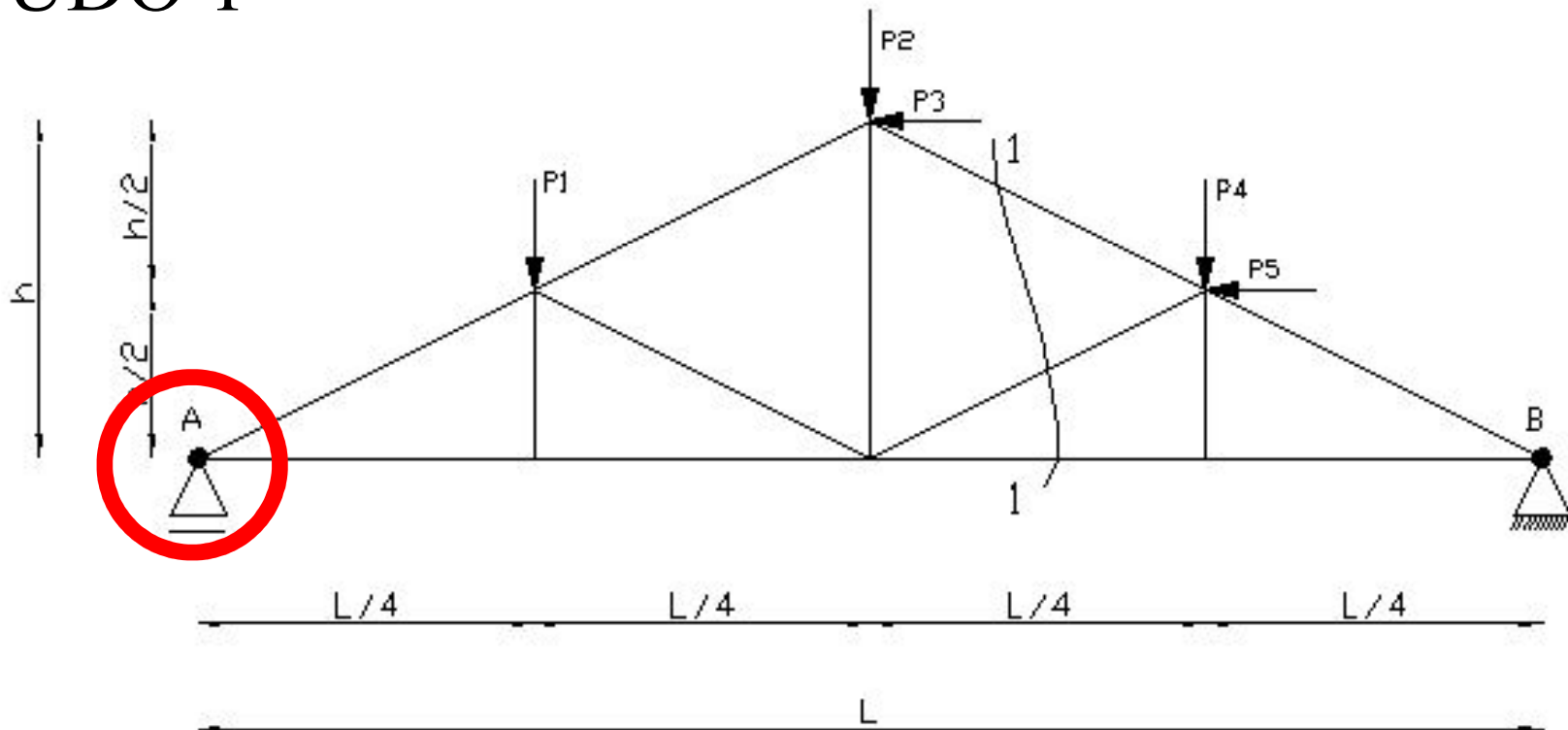

NUDO 1



$$\Sigma \mathbf{X} = \mathbf{0}$$

$$\Sigma \mathbf{Y} = \mathbf{0}$$

NUDO 1

$$R_A = 56,3 \text{ KN}$$

$$\Sigma X = 0$$

$$\Sigma Y = 0$$

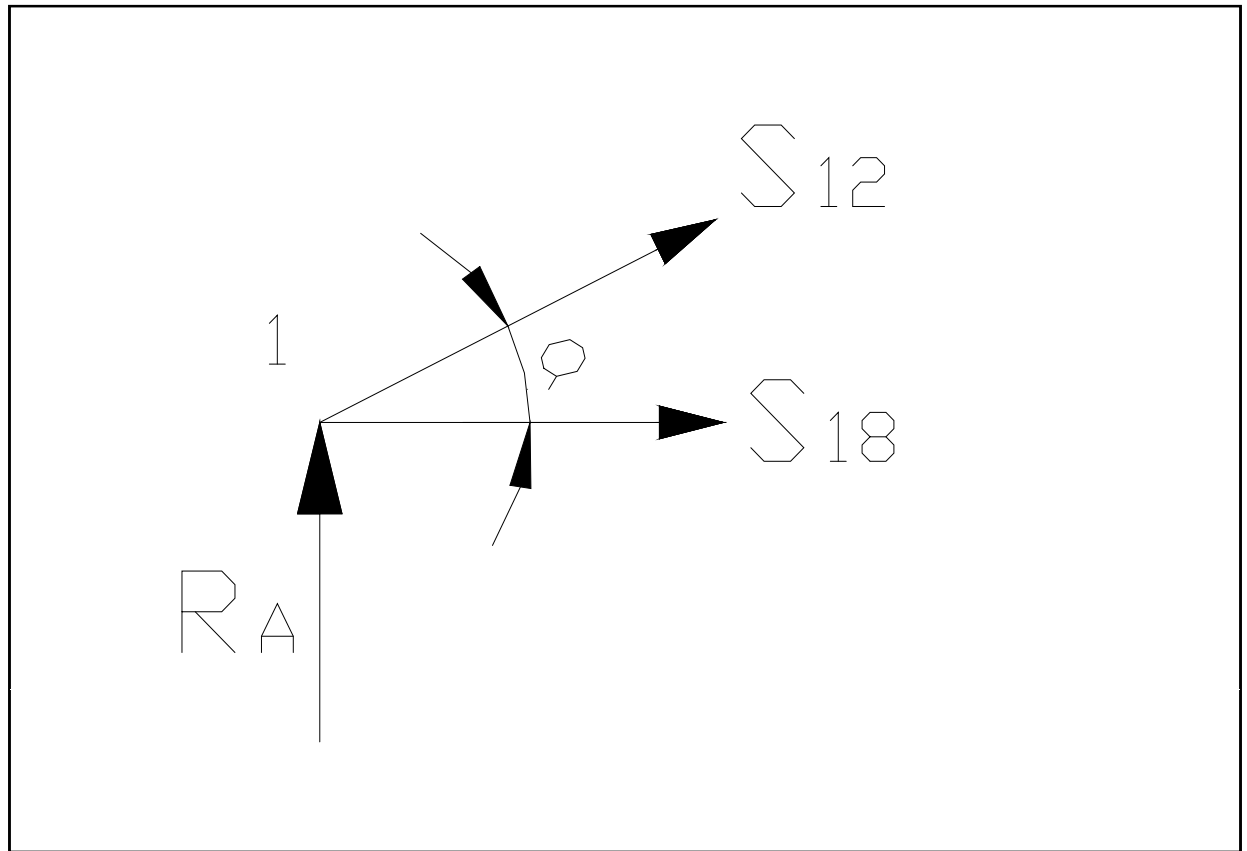

$$\Sigma X = S_{12} \cdot \cos a + S_{18} = 0$$

$$\Sigma Y = S_{12} \cdot \sin a + R_A = 0$$

$$S_{12} = -R_A / \sin a = -125,8 \text{ KN}$$

$$S_{18} = -S_{12} \cdot \cos a = 112, \text{ KN}$$

EJERCICIO MODELO

NUDO 8

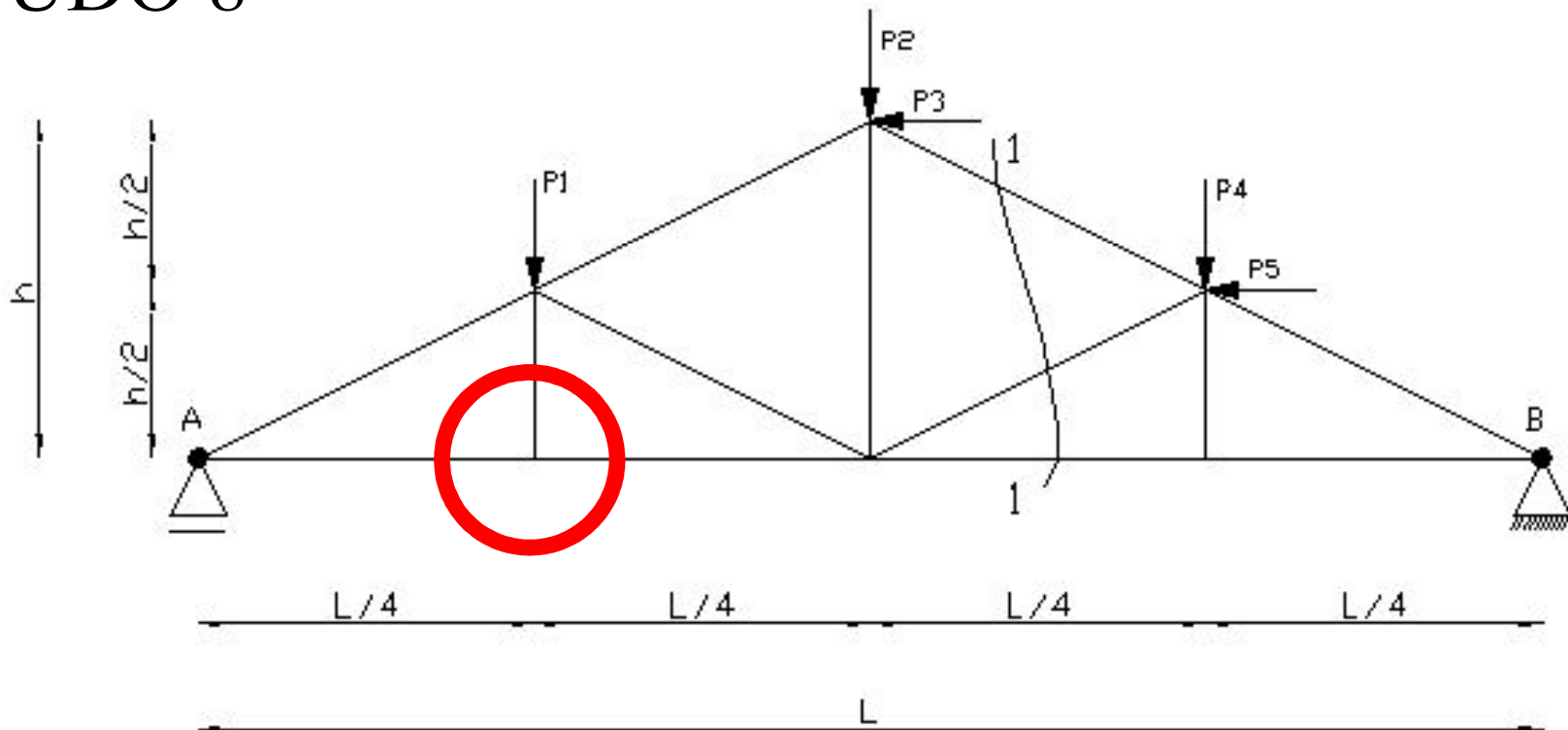

NUDO 8

$$\Sigma X = 0$$

$$\Sigma Y = 0$$

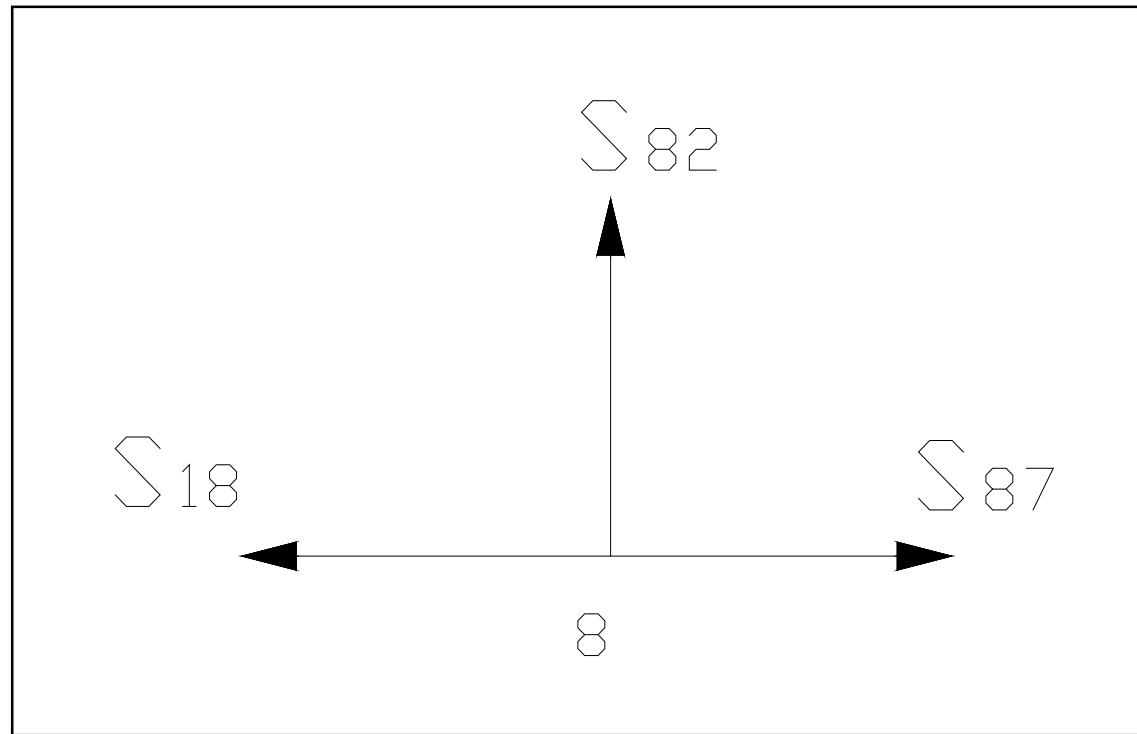

$$\Sigma X = S_{87} - S_{18} = 0$$

$$\Sigma Y = S_{82} = 0$$

$$S_{87} = S_{18} = 112,5 \text{ KN}$$

$$S_{82} = 0 \text{ KN}$$

EJERCICIO MODELO

NUDO 2

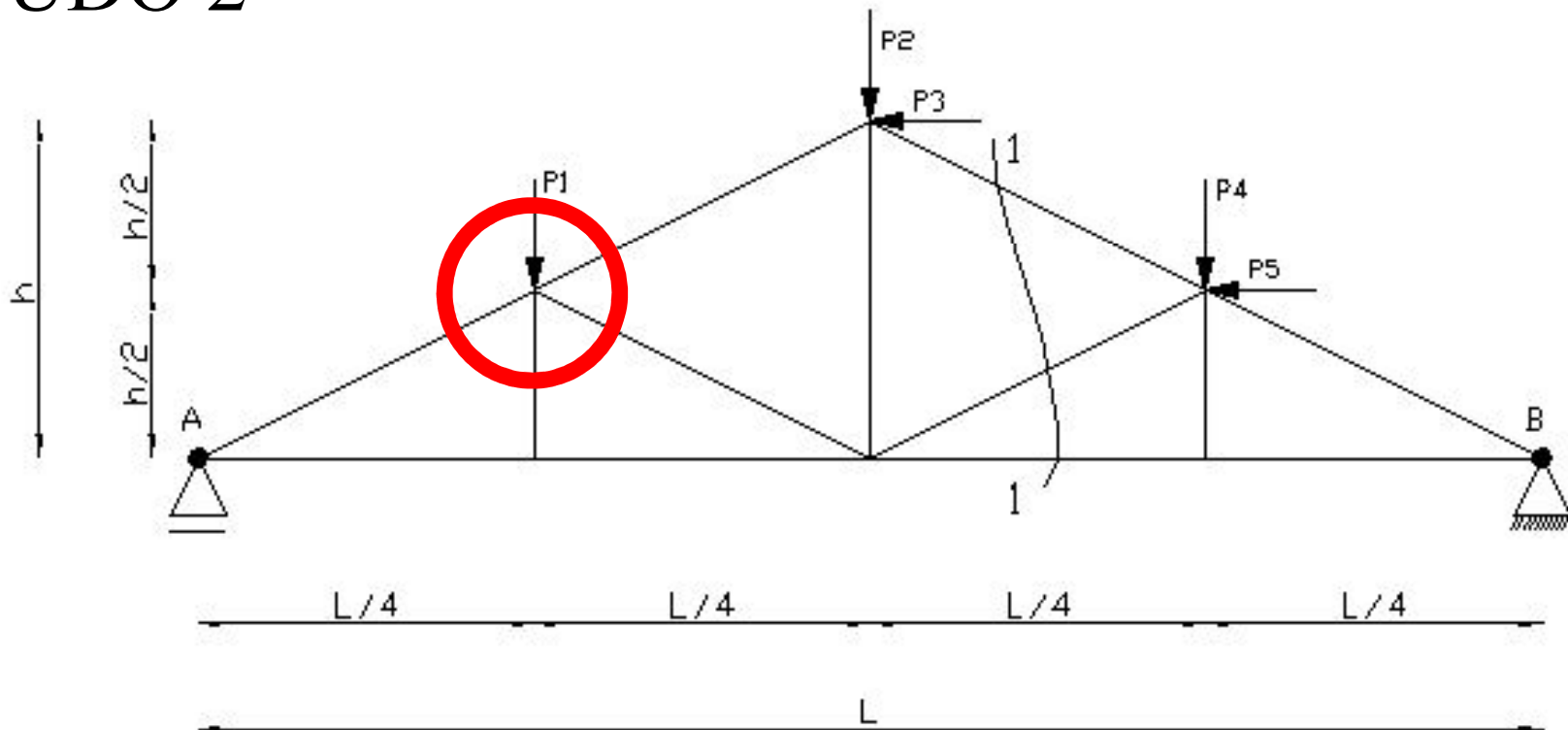

NUDO 2

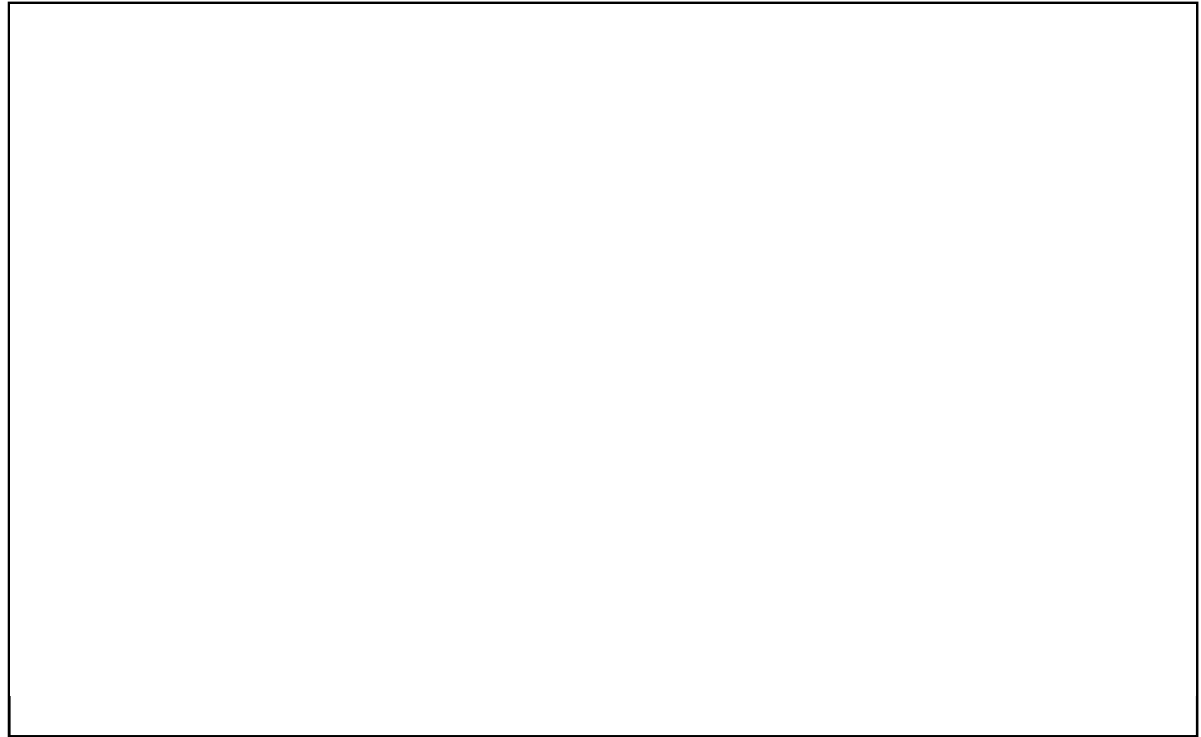

$$\Sigma X = 0$$

$$\Sigma Y = 0$$

$$\Sigma X = S_{23} \cdot \cos a + S_{27} \cdot \cos a - S_{12} \cdot \cos a = 0$$

$$\Sigma Y = -P1 + S_{23} \cdot \sin a - S_{27} \cdot \sin a - S_{82} - S_{12} \cdot \sin a = 0$$

$$S_{23} = -92,2 \text{ KN}$$

$$S_{27} = -33,5 \text{ KN}$$

EJERCICIO MODELO

NUDO 3

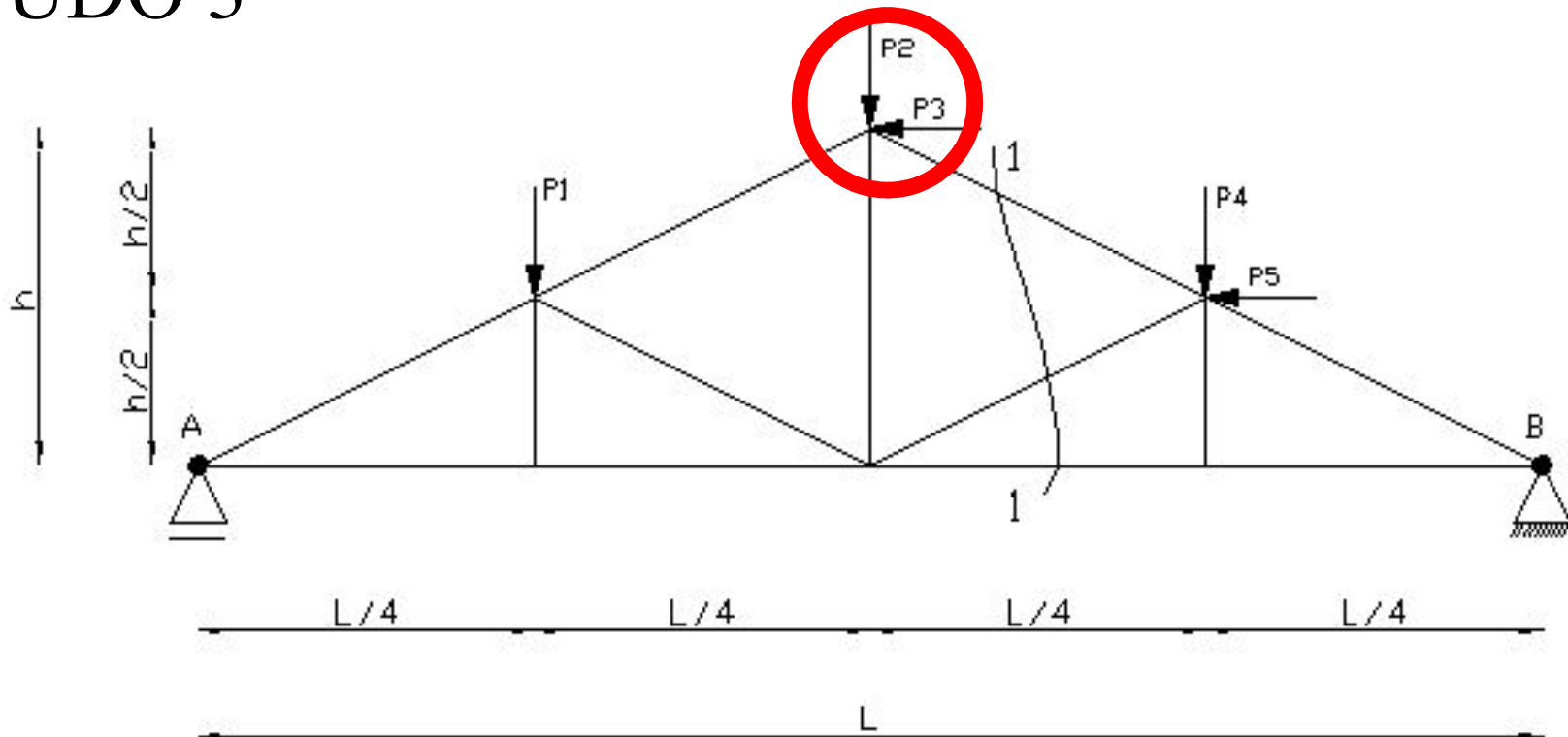

NUDO 3

$$\Sigma X = 0$$

$$\Sigma Y = 0$$

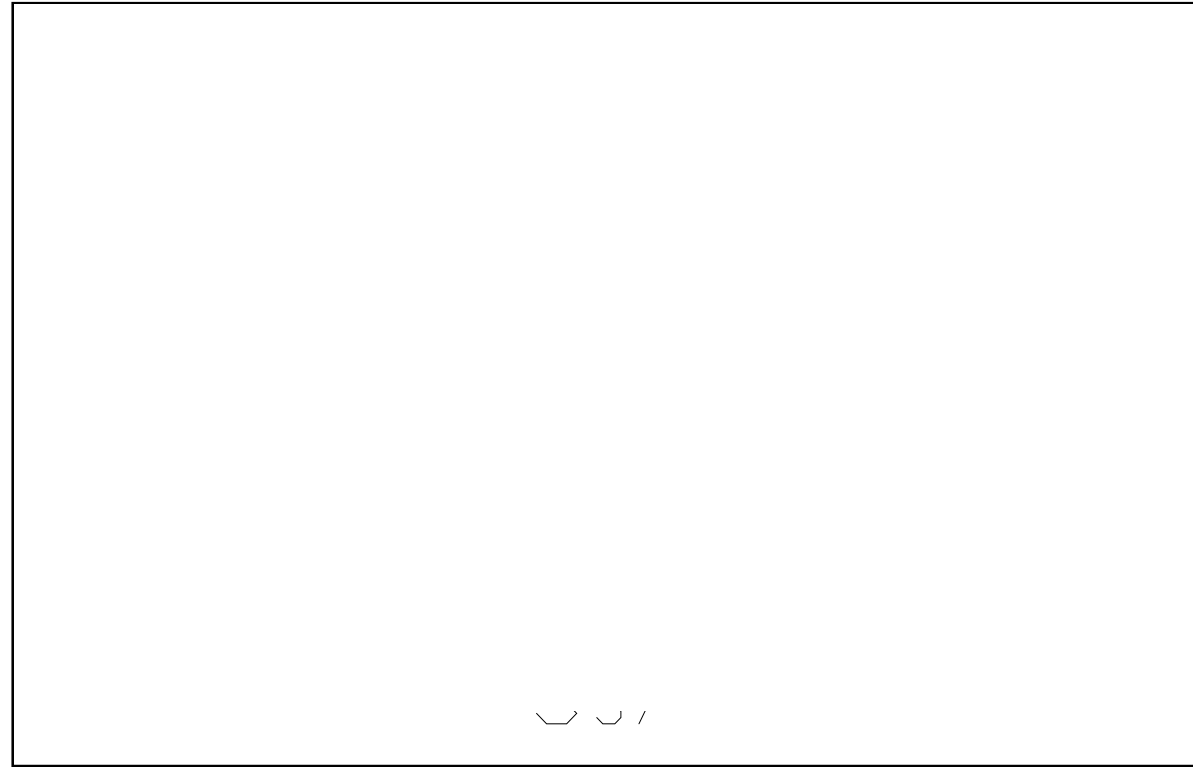

$$\Sigma X = -P3 + S_{34} \cdot \cos a - S_{23} \cdot \cos a = 0$$

$$\Sigma Y = -P2 - S_{34} \cdot \sin a - S_{37} - S_{23} \cdot \sin a = 0$$

$$S_{34} = -58,7 \text{ KN}$$

$$S_{37} = 37,5 \text{ KN}$$

EJERCICIO MODELO

NUDO 7

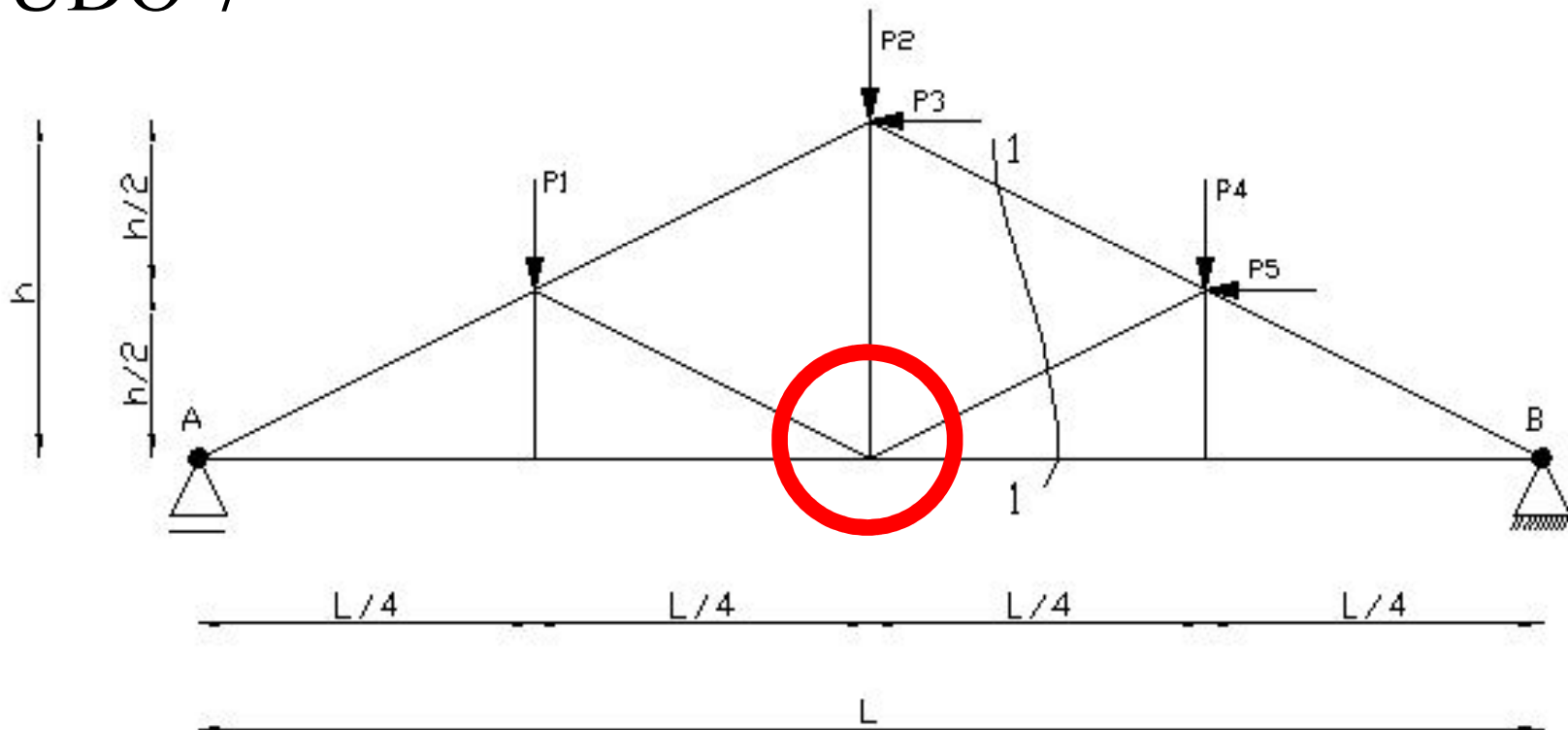

NUDO 7

$$\Sigma X = 0$$

$$\Sigma Y = 0$$

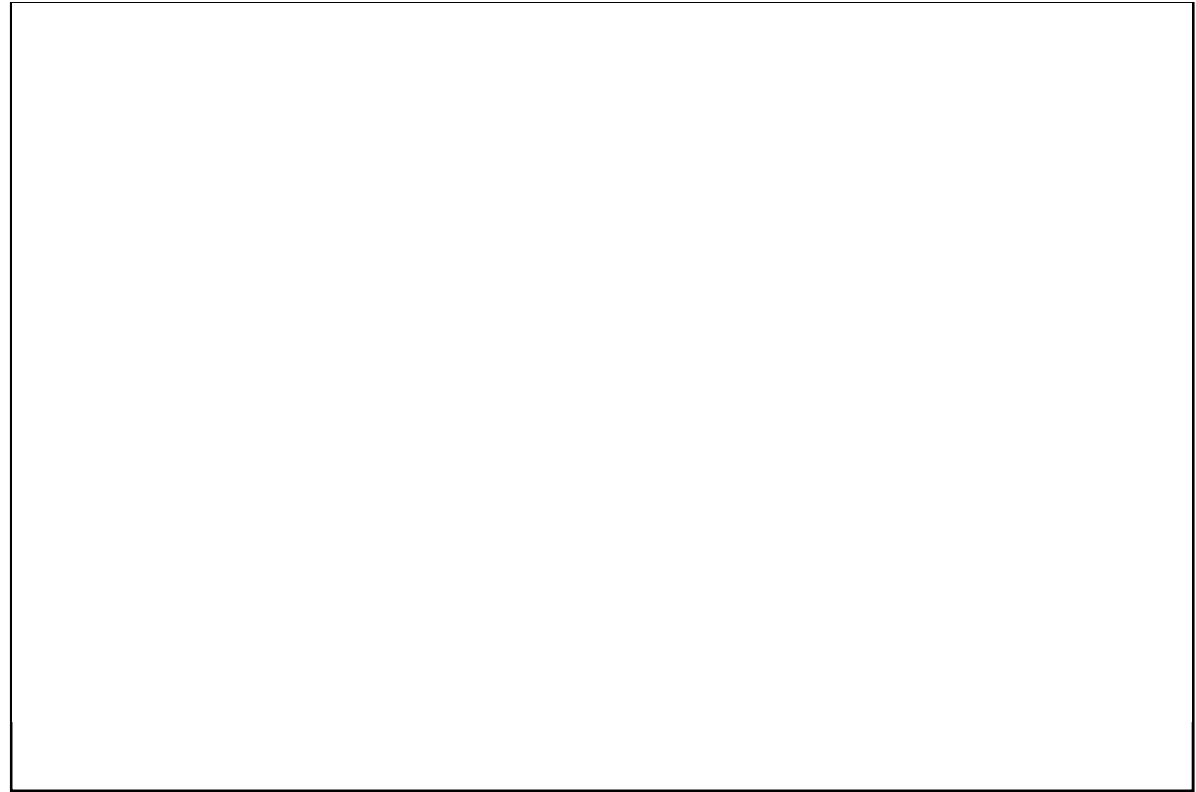

$$\Sigma X = S_{74} \cdot \cos a + S_{76} - S_{87} - S_{27} \cdot \cos a = 0$$

$$\Sigma Y = S_{37} + S_{74} \cdot \sin a + S_{27} \cdot \sin a = 0$$

$$S_{76} = 127,5 \text{ KN}$$

$$S_{74} = -50,3 \text{ KN}$$

EJERCICIO MODELO

NUDO 4

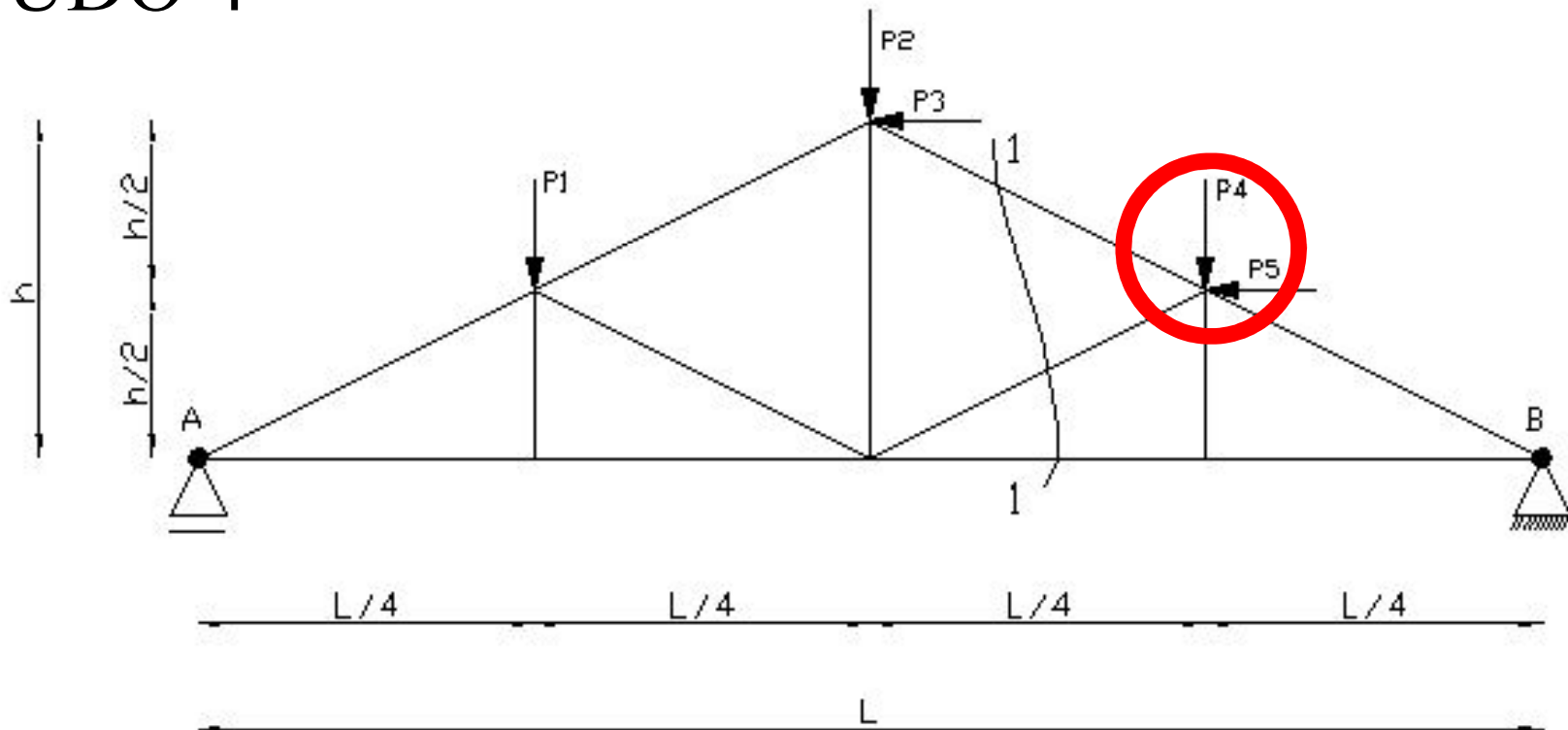

NUDO 4

$$\Sigma X = 0$$

$$\Sigma Y = 0$$

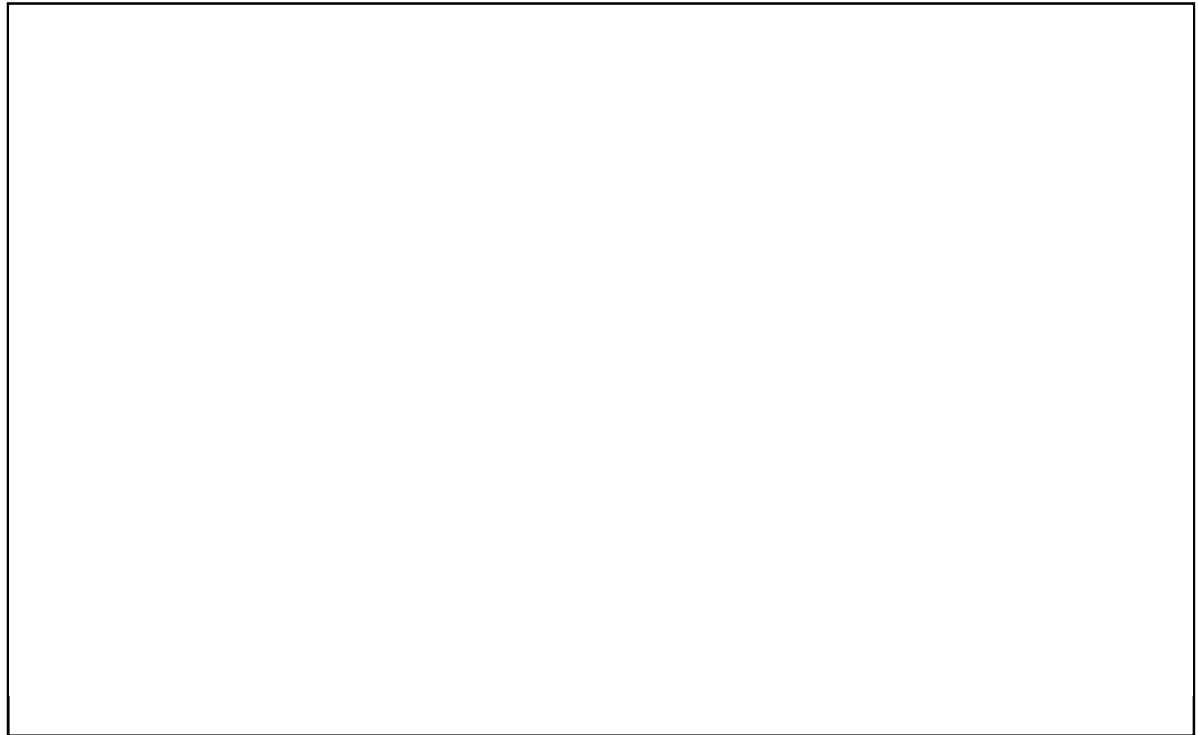

$$\Sigma X = -P5 + S_{45} \cdot \cos a - S_{74} \cdot \cos a - S_{34} \cdot \cos a = 0$$

$$\Sigma Y = -P4 - S_{45} \cdot \sin a - S_{46} - S_{74} \cdot \sin a + S_{34} \cdot \sin a = 0$$

$$S_{45} = -75,5 \text{ KN}$$

$$S_{46} = 0 \text{ KN}$$

EJERCICIO MODELO

NUDO 5

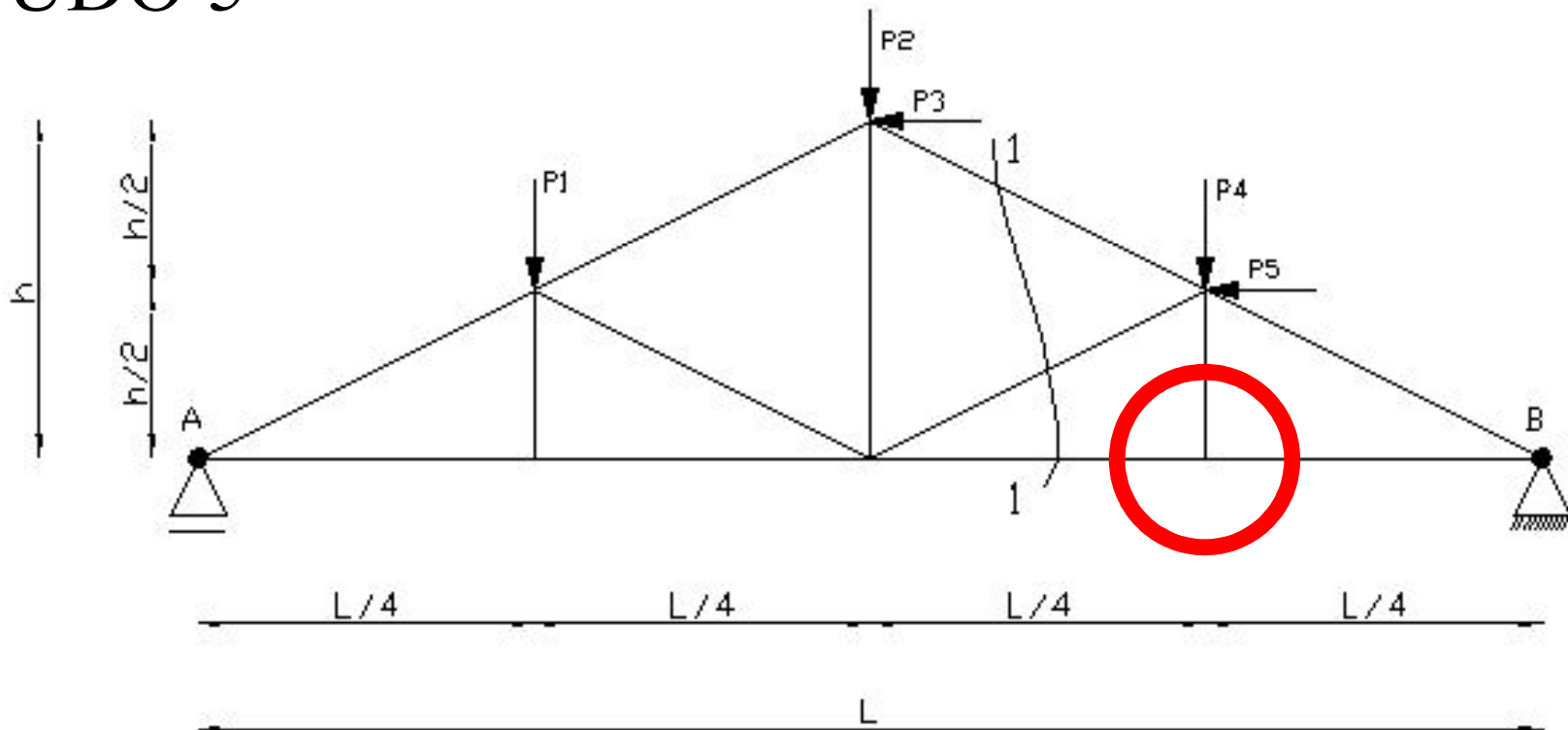

NUDO 6

$$\Sigma X = 0$$

$$\Sigma Y = 0$$

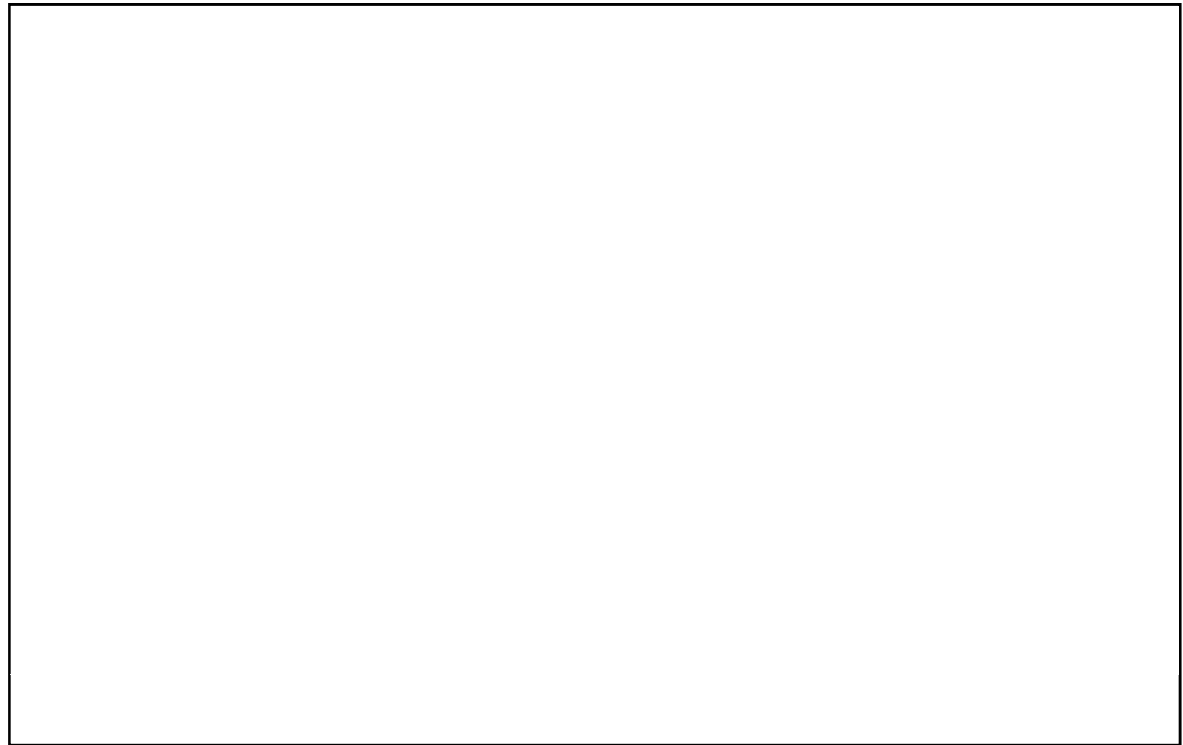

$$\Sigma X = S_{65} - S_{76} = 0$$

$$\Sigma Y = S_{46} = 0$$

$$S_{65} = 127,5 \text{ KN}$$

$$S_{46} = 0 \text{ KN}$$

EJERCICIO MODELO

NUDO 6

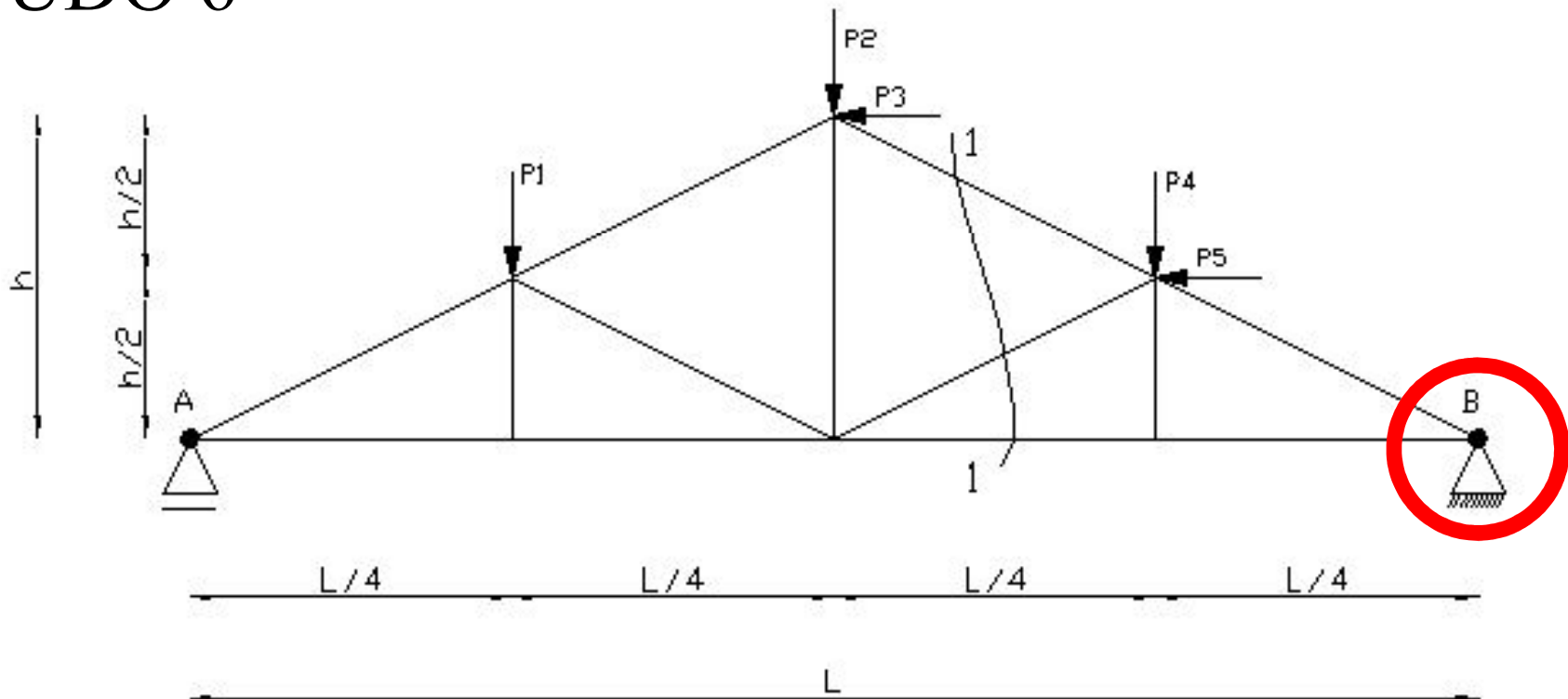

NUDO 5

$$R_{BY} = 33,7 \text{ KN}$$

$$\Sigma X = 0$$

$$\Sigma Y = 0$$

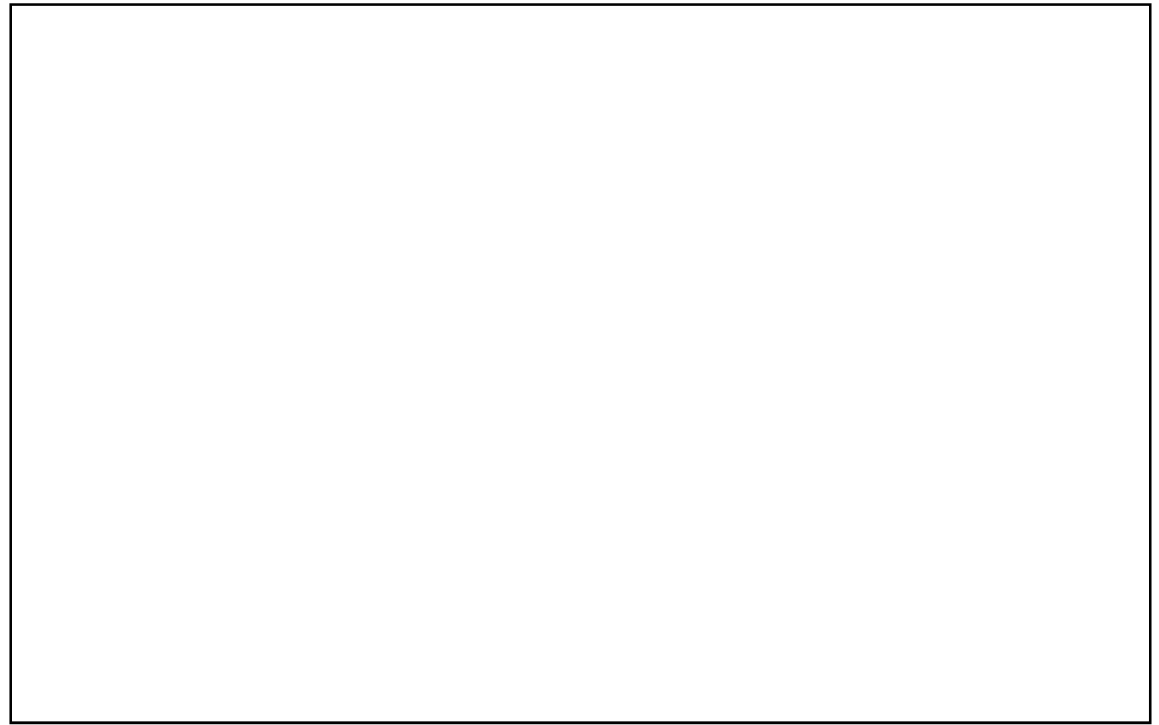

$$\Sigma X = R_{BX} - S_{65} - S_{45} \cdot \cos a = 0$$

$$\Sigma Y = S_{45} \cdot \sin a + R_{BY} = 0$$

RETICULADOS PLANOS

METODO DE LAS SECCIONES

METODO DE RITTER

MÉTODO DE LAS SECCIONES Ó DE RITTER

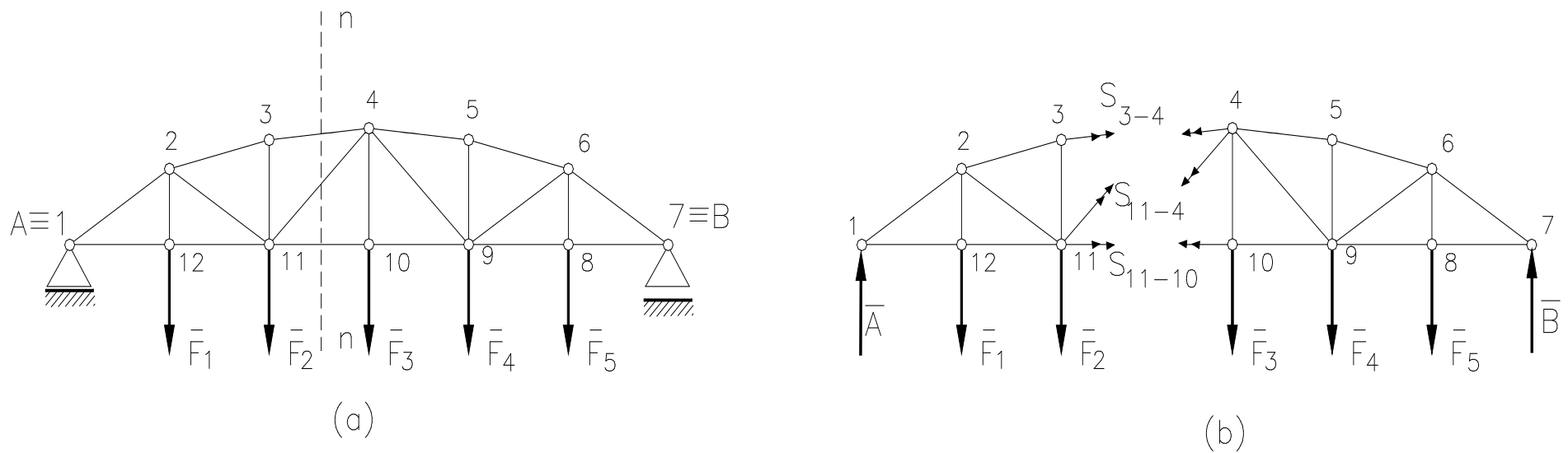
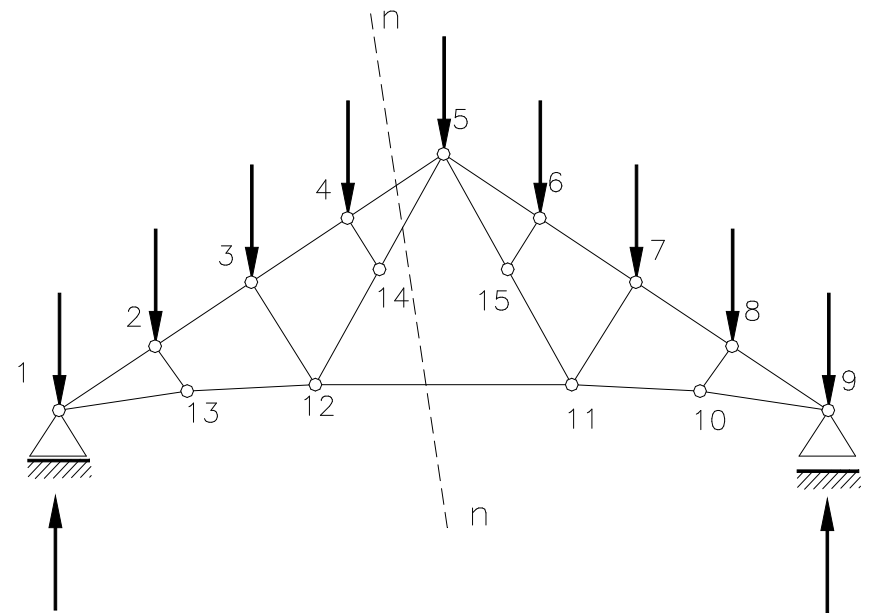
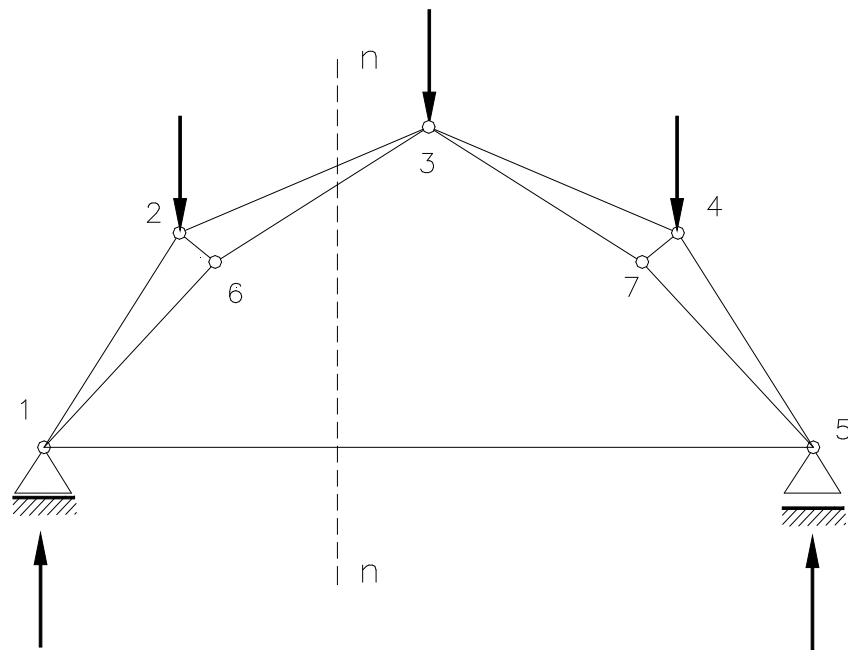

Fig. 5.16

MÉTODO DE LAS SECCIONES Ó DE RITTER



MÉTODO DE LAS SECCIONES Ó DE RITTER

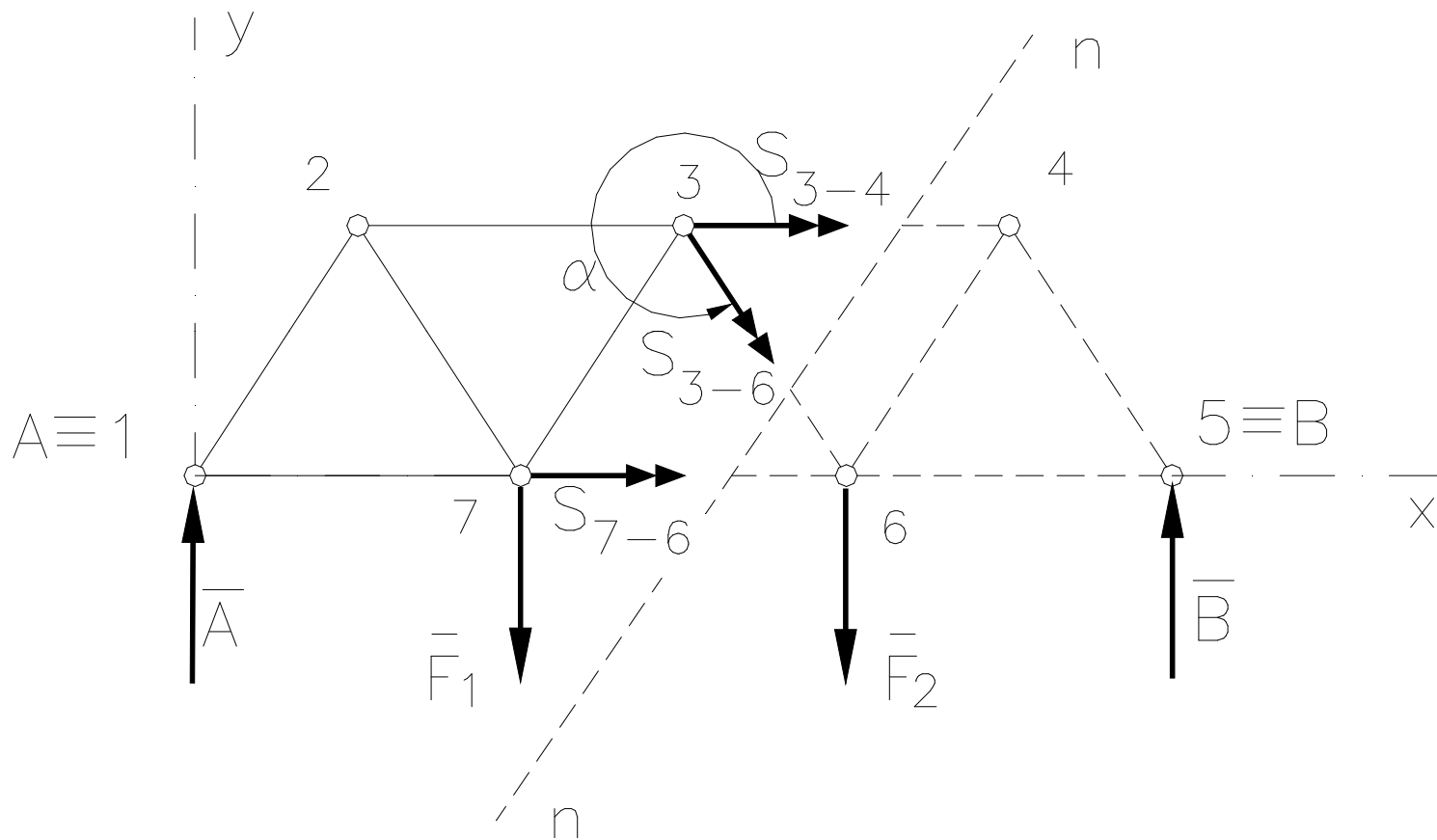
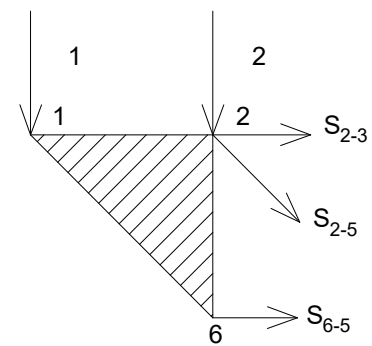
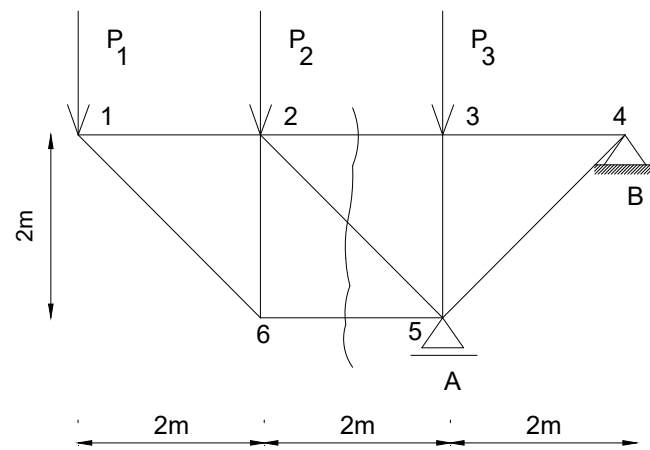

Fig. 5.19

$$P_1 = P_2 = P_3 = 1,0t$$



$$\sum F_x = 0$$

$$\sum F_y = 0$$

$$\sum M_0 = 0$$

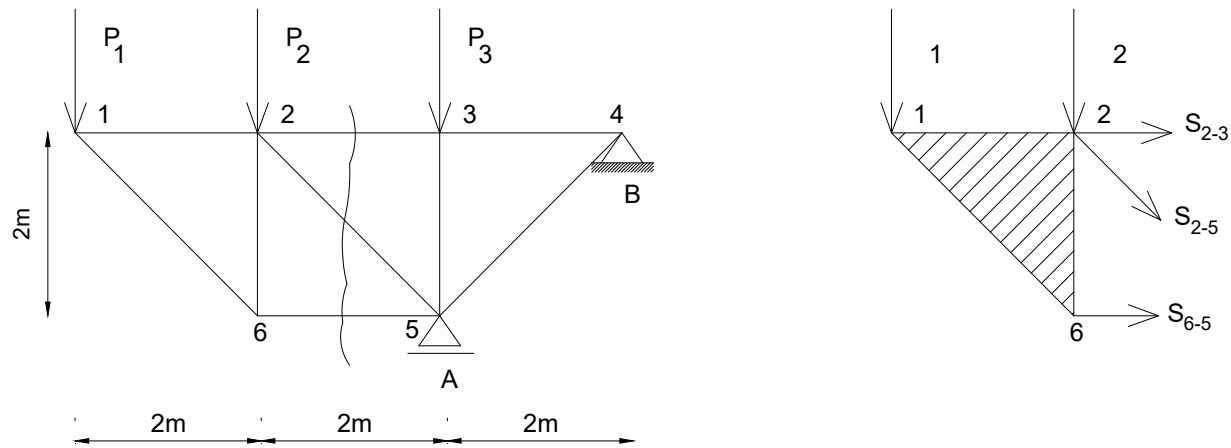

$$\sum F_y = 0 \quad ; \quad -P_1 - P_2 - P_3 + R_B = 0$$

$$R_B = -1t - 1t - 1t + 6t = 3,0t$$

$$\sum M_B = 0 \quad ; \quad -P_1 \cdot 6,0m - P_2 \cdot 4,0m - P_3 \cdot 2,0m + R_A \cdot 2,0m = 0$$

$$R_A = \frac{1t \cdot 6,0m + 1t \cdot 4,0m + 1t \cdot 2,0m}{2,0m} = 6,0t$$

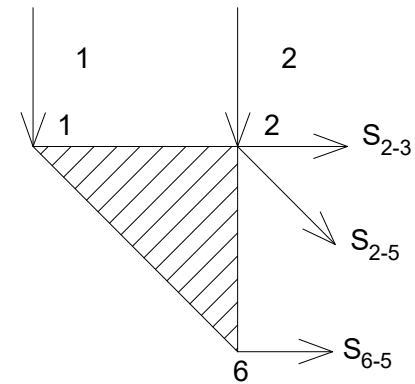
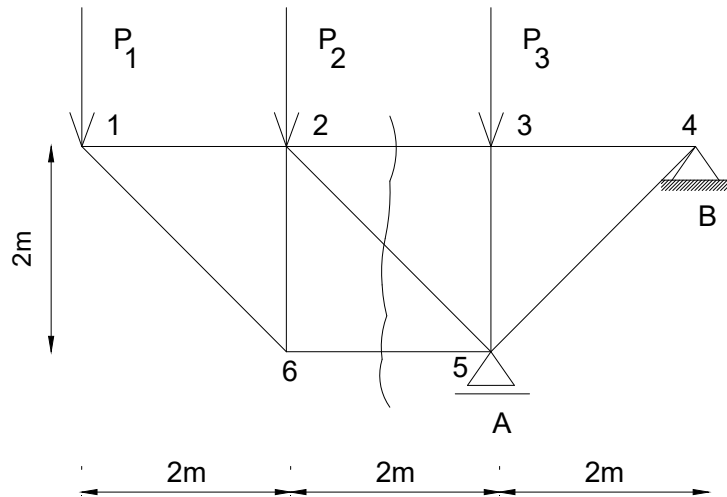

$$\sum M_5 = 0 \quad ; \quad -P_1 \cdot 4,0m - P_2 \cdot 2,0m + S_{2-3} \cdot 2,0m = 0$$

$$S_{2-3} = \frac{1t \cdot 4,0m + 1t \cdot 2,0m}{2,0m} = 3,0t \quad (\text{Tracción})$$

$$\sum M_2 = 0 \quad ; \quad -P_1 \cdot 2,0m - S_{6-5} \cdot 2,0m = 0$$

$$S_{6-5} = \frac{-1t \cdot 2,0m}{2,0m} = -1,0t \quad (\text{Compresión})$$

$$\sum F_y = 0 \quad ; \quad -P_1 - P_2 - S_{2-5} \cdot \cos(45^\circ) = 0$$

$$S_{2-5} = \frac{-1t - 1t}{0,707} = -2,83t \quad (\text{Compresión})$$

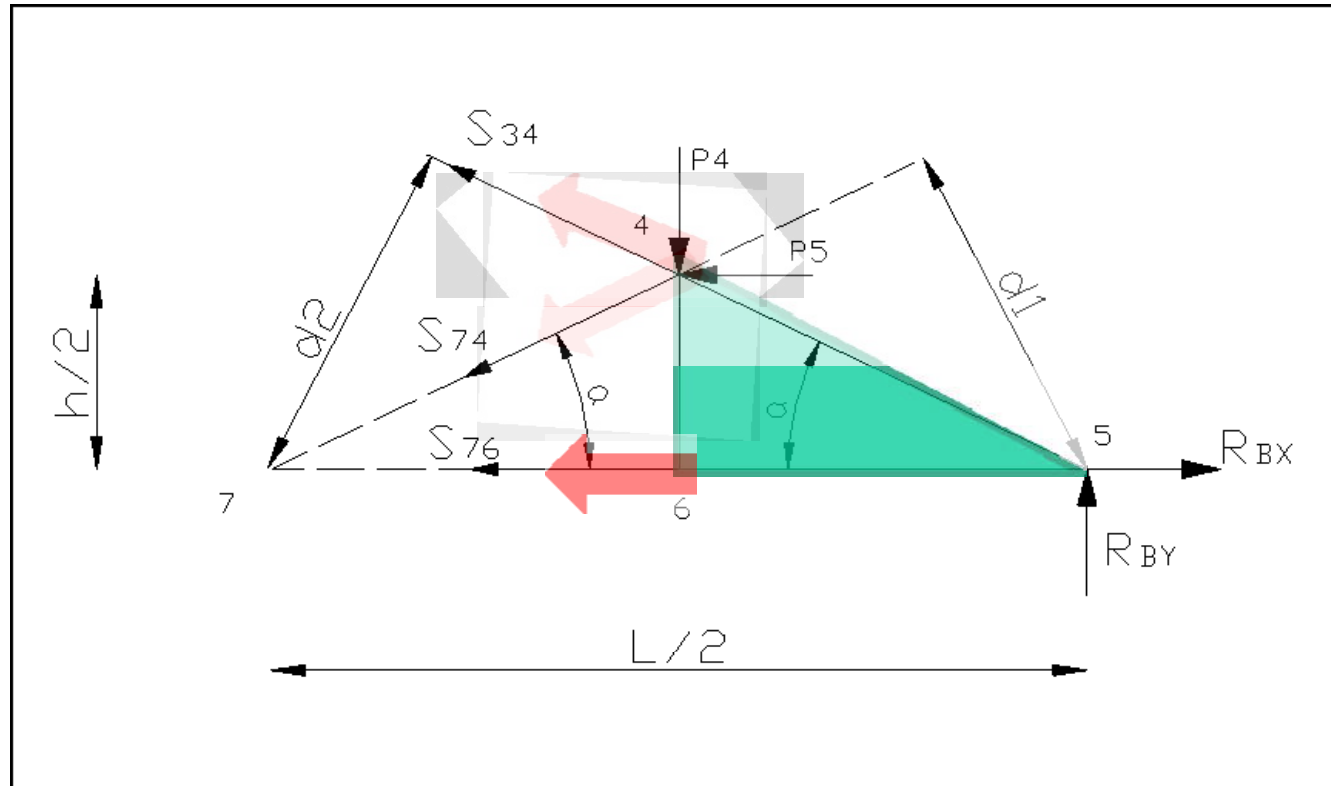

$$\Sigma M_4 = S_{76} \cdot h/2 - R_{BX} \cdot h/2 - R_{BY} \cdot L/4 = 0 \quad S_{76} = 127,5 \text{ KN}$$

$$\Sigma M_5 = -P_4 \cdot L/4 - P_5 \cdot h/2 - S_{74} \cdot d_1 = 0 \quad S_{74} = -50,3 \text{ KN}$$

$$\Sigma M_7 = P_4 \cdot L/4 - P_5 \cdot h/2 - S_{34} \cdot d_2 - R_{BY} \cdot L/2 = 0$$

$$S_{34} = -58,7 \text{ KN}$$